

**the westinghouse  
pressurized water reactor  
nuclear power plant**

**Copyright © 1984**

Westinghouse Electric Corporation  
Water Reactor Divisions

No part of this book may be reproduced in any form without permission in writing from Westinghouse Water Reactor Divisions.

Additional copies at minimal cost can be obtained by contacting:

Marketing Manager  
Nuclear Operations Division  
P.O. Box 355  
Pittsburgh, Pennsylvania 15230

# preface

This document "The Westinghouse Pressurized Water Reactor Nuclear Power Plant" is a complete revision of the "Systems Summary of a Westinghouse Pressurized Water Reactor Nuclear Power Plant" published in 1971 with subsequent reprintings.

As an introductory text to the Westinghouse PWR nuclear power plant, the original publication continues to be useful since the basic concepts of a PWR are essentially unchanged. The specifics of the design, however, have been continuously refined to meet new conditions and requirements and to reflect the dramatic increases in plant operating experience over the past decade. Accordingly, this document has been completely revised and rewritten to better reflect designs now under construction.

With few exceptions, PWR nuclear plants have electrical output ratings in the 600 megawatt to 1200 megawatt range. The descriptions herein are based on a plant with a nominal rating of 1100 megawatts electric (four-loop plant), but generally apply to smaller units as well (three-loop and two-loop plants).

This document does not describe a proposed design for an actual application nor does it imply a proposed Westinghouse scope of supply or a proposal.

An effort has been made throughout this document to use terms that are generally understood by the reader, or are at least easily definable. Selected terms related to nuclear power have been defined in the Glossary as an aid to the reader.

The term Nuclear Steam Supply System (NSSS) has been used appropriately in certain descriptions instead of the pressurized water reactor (PWR) nuclear power plant. The NSSS is that part of the power plant that consists of the PWR and systems up to and including the steam generators which supply the steam to the turbine-generator. The term containment (or plant containment) throughout when not used generally refers to the building that contains the reactor.

Of the more than 400 nuclear power plants in operation or under construction worldwide (excluding USSR and its associated countries), nearly half are PWRs furnished by Westinghouse or its licensees or former licensees. This book has been written for the technical and not-so-technical reader interested in understanding nuclear power plants and the pressurized water reactor in particular.

Whether you are an engineer, scientist, executive, teacher, or student, it is hoped that this comprehensive summary proves useful in your job performance or class study.

# acknowledgements

A book of this kind naturally requires the fine efforts of those who have the knowledge and expertise on nuclear power systems and of those who communicate it.

While it is impractical to include all those who played a part in some phase of this book, the following Westinghouse personnel have substantially contributed to the book's technical content and production:

## Technical content:

J. A. Dahlheimer  
E. E. Elhauge  
L. Greenberg  
J. H. Jacobs  
W. J. Kabbert  
H. R. Keel  
G. C. Masche  
C. N. Moran  
D. H. Petrie R. Seid  
T. G. Weiss, manager NSSS application

## Marketing communications support:

J. R. Lennartson  
S. E. Wilder

## Graphic design and illustration:

K. Cook  
H. Eltringham  
P. B. Montgomery

Our grateful appreciation for all thoughts and for all hands.

Alex Kunkle, technical coordination  
Don Testa, editor



# table of contents

Chapter Number	Title	Page
CHAPTER 1	SUMMARY DESCRIPTION	1
	Introduction	2
	Pressurized Water Reactor Design Concept	3
	Nuclear island	4
	Turbine island	7
	Plant layout	10
CHAPTER 2	REACTOR CORE AND NUCLEAR CHARACTERISTICS	13
	Introduction	14
	Fuel Pellets	16
	Fuel Rods	16
	Fuel Assemblies	18
	Rod Cluster Control Assemblies	20
	Core Thermal-Hydraulic Design	20
	Reactivity Control	21
	Reactor Startup Neutron Sources	26
CHAPTER 3	REACTOR COOLANT SYSTEM	27
3.1	Reactor Vessel And Internals	29
	Reactor Vessel	29
	Reactor Internals	33
3.2	Control Rod Drive Mechanisms	38
3.3	Reactor Coolant Pumps	41
	Hydraulic Unit	41
	Heat Exchanger	41
	Lower Bearing	43
	Injection Water	43
	Shaft Seal System	43
	Shaft Spool Piece	45
	Motor	45
	Grounding Pad	46
	Assembly	46
	Pump Support	46
	Vibration Monitoring Equipment	46
	Locked Rotor Protection System	47
	Oil Spillage Protection and Control System	47

Chapter Number	Title	Page
CHAPTER 3	REACTOR COOLANT SYSTEM (CONT)	27
3.4	Steam Generators	48
3.5	Pressurizer	52
	Pressurizer Level Control System	52
	Pressurizer Pressure Control System	55
3.6	Piping and Valves	56
	Piping and insulation	56
	Valves	56
CHAPTER 4	AUXILIARY FLUID SYSTEMS	57
4.1	Chemical and Volume Control System	58
	System Description	58
	System Operation	60
4.2	Boron Thermal Regeneration System	63
	System Description	63
	System Operation	65
4.3	Residual Heat Removal System	68
	System Description	68
	System Operation	70
4.4	Boron Recycle System	72
	System Description	72
	System Operation	72
4.5	Steam Generator Blowdown Processing System	74
	System Description	74
	System Operation	74

<b>Chapter Number</b>	<b>Title</b>	<b>Page</b>
<b>CHAPTER 5</b>	<b>ENGINEERED SAFEGUARDS SYSTEMS</b>	<b>78</b>
5.1	Safety Injection System	79
	System Description	79
	System Operation	81
5.2	Emergency Feedwater System	83
	System Description	83
	System Operation	85
5.3	Component Cooling Water System	87
	System Description	87
	System Operation	89
<b>CHAPTER 6</b>	<b>CONTAINMENT SYSTEMS</b>	<b>91</b>
	Containment Structural Design	92
	Isolation System	98
	Containment Spray System	98
	Containment Fan Cooler System	100
	Hydrogen Detection And Suppression System	102
<b>CHAPTER 7</b>	<b>INSTRUMENTATION AND CONTROL</b>	<b>103</b>
	Nuclear Measurements	104
	Digital Rod Position Indication System	110
	Process Instrumentation	113
	Nuclear Steam Supply Control System	113
	Reactor protection System	121
<b>CHAPTER 8</b>	<b>PLANT CONTROL ROOM</b>	<b>126</b>
	The Advanced Control Room	127
	On-site Technical Support Center and Emergency Operations Facility	132

Chapter Number	Title	Page
CHAPTER 9	PLANT COMPUTER	134
	Man-Machine Interface	135
	Computer System Functions	137
	Nuclear Steam Supply System Process Supervision	139
CHAPTER 10	RADIATION MONITORING SYSTEM	142
	Digital Radiation Monitoring System	143
CHAPTER 11	PLANT ELECTRICAL SYSTEMS	148
	6600-Volt and 480-Volt Systems	149
	Diesel Generators	150
	125-Volt DC Power System	150
	Inverter Power Supply For Essential Services	152
CHAPTER 12	AUXILIARY COOLING SYSTEMS	153
	Circulating Water System	154
	Service Water System	154
	Spent Fuel Pool Cooling System	155
CHAPTER 13	FUEL HANDLING SYSTEM	156
	Fuel Handling Facilities	157
	Refueling Equipment	162
	Refueling Operation	167
	New Fuel Handling	171
	Sigma Manipulator Crane	172
	Reactor Cavity Filtration System	172
CHAPTER 14	WASTE PROCESSING SYSTEMS	173
	Liquid Waste Processing System	174
	Gaseous Waste Processing System	174
	Solid Waste Processing Systems	175

Chapter Number	Title	Page
CHAPTER 15	TURBINE-GENERATOR AND RELATED SYSTEMS	181
15.1	Main Turbine	183
	General Description	183
	Control Valves	183
	Cylinders	183
	Rotors	184
	Blading	185
	Electro-Hydraulic Control System	186
	Protective Devices	190
15.2	Main Generator	192
	Ventilation	192
	Stator Coils and Winding	192
	Generator Rotor	193
	Stator Coil Cooling Water System	194
	Excitation System	194
15.3	Main Steam and Repeaters	199
	Main Steam	199
	Reheat Steam	199
	Condensing Equipment	200
	Turbine Steam Dump System	200
15.4	Feedwater Heating System (Turbine)	204
	Feedwater Heaters	204
	Condensate Pumps	204
	Feedwater and Feedwater Booster Pumps	204
	Feedwater Heater Drains	205
CHAPTER 16	PLANT OPERATION	206
	Startup	207
	Normal Operation	210
	Shutdown	211
	Maintenance	212
	Load Follow Capability	214
	Load Follow Features	215

<b>Chapter Number</b>	<b>Title</b>	<b>Page</b>
CHAPTER 16	PLANT OPERATION (CONT)	206
	Load Follow Operation	215
	Daily Load Follow	216
	Full Load Rejection Capabilities	217
	Plant Emergency Response	217
CHAPTER 17	SAFETY CONDERATIONS	219
	First Level of Defense	220
	Second Level of Defense	221
	Third Level of Defense	222
GLOSSARY		224

# list of tables

<b>Table Number</b>	<b>Title</b>	<b>Page</b>
CHAPTER 1	SUMMARY DESCRIPTION	
1-1	Principal Data for Current Westinghouse NSSS Models	3
CHAPTER 2	REACTOR CORE AND NUCLEAR CHARACTERISTICS	
2-1	Typical Reactor Core Parameters	14
2-2	Fuel Rod Parameters (Four-Loop Plant)	18
CHAPTER 3	REACTOR COOLANT SYSTEM	
3.1-1	Reactor Vessel Principal Parameters	31
3.2-1	Principal Parameters of Control Rod Drive Mechanisms	38
3.3-1	Reactor Coolant Pump Typical Design Parameters	41
3.4-1	Steam Generator Principal Design Data	50
3.5-1	Pressurizer Principal Design Data	54
CHAPTER 7	INSTRUMENTATION AND CONTROL	
7-1	Engineered Safety Features Signals of the Integrated Protection System	125
CHAPTER 8	PLANT CONTROL ROOM	
8-1	Control Room Information Devices	129
8-2	Control Room Operation Action Devices	130
CHAPTER 9	PLANT COMPUTER	
9-1	Computer Information Devices	136
CHAPTER 10	RADIATION MONITORING SYSTEM	
10-1	Radiation Monitoring System Typical Monitors	144
CHAPTER 13	FUEL HANDLING SYSTEM	
13-1	Radiation Levels as a Function of Water Depth Above Fuel Assembly	161
13-2	Major Refueling Operations (Estimate of Time and Manhours)	168

<b>Table Number</b>	<b>Title</b>	<b>Page</b>
CHAPTER 16	PLANT OPERATION	
16-1	Estimated Startup Time in Hours Required by NSSS	208



# list of figures

Figure Number	Title	Page
CHAPTER 1 SUMMARY DESCRIPTION		
1-1	Westinghouse PWR Nuclear Power Plant, Simplified Schematic Diagram	4
1-2	Main Steam and Feedwater System, Simplified Diagram	9
1-3	Two-Unit Nuclear Power Station, Plan View	11
1-4	Nuclear Power Station, Cross Section of One Unit	12
CHAPTER 2 REACTOR CORE AND NUCLEAR CHARACTERISTICS		
2-1	Cross Section of Typical Four-Loop Core (193 Fuel Assemblies)	15
2-2	Typical Fuel Assembly with Rod Cluster Control	16
2-3	Cutaway of 17 x 17 Optimized Fuel Assembly with RCC	17
2-4	Fuel Pellets	18
2-5	Cross Section of 17 x 17 Fuel Assemblies with and without Rod Cluster Control	19
2-6	Portion of Spring Clip Grid Assembly	19
2-7	Arrangement of Rod Cluster Control Assemblies in the Reactor Core	23
2-8	Fuel Loading Pattern	24
2-9	Burnable Absorber Loading Pattern for a Typical First Core	25
2-10	Boron Concentration versus Cycle with and without Burnable Absorber Rods	26
CHAPTER 3 REACTOR COOLANT SYSTEM		
3-1	Reactor Coolant System, Flow Diagram	28
3.1-1	Cutaway of a Typical Reactor (Four-Loop Plant)	30
3.1-2	Reactor Vessel Upper Core Support Structure	34
3.1-3	Reactor Vessel Lower Internals Assembly	35
3.2-1	Cutaway of a Typical Control Rod Drive Mechanism	39
3.3-1	Cutaway of a Typical Reactor Coolant Pump	42
3.3-2	RCP Typical Shaft Seal Arrangement	44
3.4-1	Cutaway of a Typical Steam Generator	49
3.5-1	Cutaway of the Pressurizer	53

<b>Figure Number</b>	<b>Title</b>	<b>Page</b>
<b>CHAPTER 4    AUXILIARY FLUID SYSTEMS</b>		
4.1-1	Chemical and Volume Control System, Flow Diagram	59
4.2-1	Boron Thermal Regeneration System (Dilution), Flow Diagram	64
4.2-2	Boron Thermal Regeneration System (Boration), Flow Diagram	66
4.3-1	Safety Injection/Residual Heat Removal System, RHR Mode	69
4.4-1	Boron Recycle System, Flow Diagram	73
4.5-1	Steam Generator Blowdown Processing System, Flow Diagram	76
4.5-2	SGBPS Spent Resin Storage Tank	77
<b>CHAPTER 5    ENGINEERED SAFEGUARDS SYSTEMS</b>		
5.1-1	Safety Injection/Residual Heat Removal System, Injection Mode	80
5.2-1	Emergency Feedwater System, Flow Diagram	84
5.3-1	Component Cooling Water System, Flow Diagram	88
<b>CHAPTER 6    CONTAINMENT SYSTEMS</b>		
6-1	Typical Prestressed Concrete Containment	93
6-2	Typical Steel Cylindrical Containment	93
6-3	Typical Prestressed Containment, Construction Details	94
6-4	Containment Spray System (One of Two Trains), Flow Diagram	99
6-5	Reactor Containment Fan Cooler	101
<b>CHAPTER 7    INSTRUMENTATION AND CONTROL</b>		
7-1	Nuclear Instrumentation System Neutron Detectors and Range of Operation	106
7-2	Typical In-Core Instrumentation System	107
7-3	Typical Drive Train for In-Core Instrumentation	109
7-4	Rod Position Indicating System, Block Diagram	111
7-5	Safety-Grade RPI Configuration	112
7-6	NSSS Integrated Plant Control System	115
7-7	Power Control System	116
7-8	Axial Offset Control Criteria	118
7-9	RPS Reactor Trip Actuation, Block Diagram	124

<b>Figure Number</b>	<b>Title</b>	<b>Page</b>
<b>CHAPTER 8 PLANT CONTROL ROOM</b>		
8-1	Typical Plant Control Room	128
8-2	Typical Advanced Control Room Layout	133
<b>CHAPTER 9 PLANT COMPUTER</b>		
9-1	Typical Mimic Display	137
9-2	Typical PWR Bar Chart Display	138
9-3	Operating Limits Curve	139
9-4	Typical PWR Polar Plot	140
<b>CHAPTER 10 RADIATION MONITORING SYSTEM</b>		
10-1	Radiation Monitoring System, Block Diagram	145
10-2	RMS Safety Subsystem, Block Diagram	146
<b>CHAPTER 11 PLANT ELECTRICAL SYSTEMS</b>		
11-1	Typical PWR Nuclear Power Station Electrical System, One-Line Diagram	151
<b>CHAPTER 13 FUEL HANDLING SYSTEM</b>		
13-1	Fuel Handling Layout	158
13-2	Typical Fuel Handling Arrangement	159
13-3	Permanent Cavity Seal Ring	160
13-4	Dual Basket Fuel Transfer Car	165
<b>CHAPTER 14 WASTE PROCESSING SYSTEMS</b>		
14-1	Liquid Waste Processing System, Flow Diagram	176
14-2	Gaseous Waste Processing System, Flow Diagram	177
14-3	Radwaste Volume Reduction System, Flow Diagram	178
14-4	Radwaste Incinerator	179
14-5	Cement Solidification System, Flow Diagram	180

<b>Figure Number</b>	<b>Title</b>	<b>Page</b>
<b>CHAPTER 15 TURBINE-GENERATOR AND RELATED SYSTEMS</b>		
15-1	Turbine-Generator	182
15.1-1	Four-Cylinder Turbine, Cross Section	184
15.1-2	Portion of Blading of Low-Pressure Element	185
15.1-3	Cross Section of Low-Pressure Turbine Rotor	186
15.1-4	Electro-Hydraulic Control System for Large Steam Turbine-Generators	187
15.1-5	Overall Configuration of Digital Electro-Hydraulic Master Control System	189
15.1-6	DEH Base Operator's Panel	190
15.1-7	Master Operator's Panel	191
15.2-1	1800 Rpm Inner-Cooled Generator	193
15.2-2	Stator Windings	194
15.2-3	Rotor End Winding	195
15.2-4	Stator Coil Cooling Water System	196
15.2-5	Cutaway of Brushless Exciter	197
15.2-6	Brushless Excitation System	198
15.3-1	Typical Steam, Condensate and Feedwater System, Flow Diagram	201
15.3-2	Moisture Separator-Reheater, Two Stage	202
15.3-3	Steam Dump System, One-Line Diagram	203

# **chapter 1**

## **summary description**

## INTRODUCTION

There have been a considerable number of nuclear reactor concepts proposed over the thirty years of applied nuclear power. A selected number of these have been developed to the extent that one or more plants have been built. Today, only three of these concepts are considered commercially viable\*. Two of these concepts are based on the use of uranium enriched in the isotope U-235 with light (or ordinary) water employed for cooling and neutron moderation. Of these two concepts, one is the pressurized water reactor or PWR developed by Westinghouse. The other is the boiling water reactor or BWR developed by General Electric. The third concept is based on the use of natural uranium with heavy-water (water enriched in the deuterium isotope) for cooling and moderation. This reactor concept has been principally developed and applied by Atomic Energy of Canada Limited. Worldwide, of the over 400 nuclear power plants operating or under construction, over 75 percent of these are of the light-water design with over 65 percent of the light-water plants being PWRs furnished by Westinghouse and its current or original licensees.

The fundamental distinction between the PWR and the BWR is that in the latter the coolant moderator is allowed to boil with the resulting steam passed directly to the turbine-generator, whereas in the PWR the coolant moderator is maintained above saturation pressure such that no significant amount of boiling occurs in the reactor. The necessary steam for the turbine-generator is produced in a steam generator

where the reactor heat is transferred to a secondary water coolant at lower pressure.

There are of course a considerable number of other less fundamental differences as well. The importance of these differences have been examined in a large number of utility evaluations with the clearest and simplest overall result being the current commercial dominance of the PWR design.

This document describes the basic design and operating characteristics of a Westinghouse PWR plant. The design is available in five ratings of approximately 600 megawatts electrical (MWe), 900 MWe, 1000 MWe, 1100 MWe, and 1200 MWe. (The exact ratings of course reflect a number of specific constraints such as heat sink characteristics.) The different ratings are attained through use of either two, three or four reactor coolant piping loops, each loop comprised of a steam generator, reactor coolant pump, and interconnecting piping. The loops are each connected to a reactor vessel sized to contain nuclear cores comprised of fuel elements of either 12 or 14 foot length with from 121 to 193 assemblies. In this manner the full range of utility requirements can be satisfied while maximizing the use of standard components. The principal parameters for the various power ratings are given in Table 1-1.

The description given in this document is based on a four-loop plant with a twelve foot core (a Model 412 plant) having an electrical capacity of some 1100 MWe. The descriptions generally apply equally to the other ratings when proper consideration is given to the number of reactor coolant loops and/or core length. For all ratings, the functional system requirements and operating characteristics are essentially the same. Where system or plant operation is

---

\* This discussion considers only the situation outside the Comecon bloc associated with the Soviet Union

described, the actions and sequences are based on current Westinghouse recommendations.

## PRESSURIZED WATER REACTOR DESIGN CONCEPT

A simplified schematic of the Westinghouse PWR plant design is shown in Figure 1-1. The total power cycle may be considered to be comprised of three generally independent closed cycles or loops: primary, secondary, and tertiary.

The primary loop contains the heat source consisting of a nuclear fuel core positioned within a reactor vessel where the energy resulting from the controlled fission reaction is transformed into sensible heat in the coolant-moderator. The coolant is pumped to the steam

generator where the heat is transferred to a secondary loop through a number of U-type tubes. The reactor coolant then returns back to the reactor vessel to continue the process. An electrically heated pressurizer connected to the loop maintains a pressure above the saturation pressure so that bulk boiling does not occur.

The secondary loop is the heat utilization circuit where dry steam produced in the steam generator flows to a turbine-generator where it is expanded to convert thermal energy into mechanical energy and hence electrical energy. The expanded steam exhausts to a condenser where the latent heat of vaporization is transferred to the cooling system and is condensed. The condensate is pumped back to the steam generator to continue the cycle.

**TABLE 1-1  
PRINCIPAL DATA FOR CURRENT WESTINGHOUSE NSSS MODELS**

<b>Model: Number of Loops:</b>	<b>212 2</b>	<b>312 3</b>	<b>412 4</b>	<b>414 4</b>
NSSS power, megawatt thermal	1882	2785	3425	3819
Approximate electrical output, MWe	600	900	1150	1280
Steam pressure, psia (bar)	920 (63)	960 (66)	1000 (69)	1100 (76)
Reactor vessel ID, in. (cm)	132 (335.3)	157 (398.8)	173 (439.4)	173 (439.4)
Steam generator model	F	F	F	H
Reactor coolant pump type	93A1	93A1	93A1	93A1
RCP motor horsepower	7000	7000	7000	9000
Hot leg ID, in. (cm)	29 (73.7)	29 (73.7)	29 (73.7)	29 (73.7)
Cold leg ID, in. (cm)	27.5 (69.9)	27.5 (69.9)	27.5 (69.9)	27.5 (69.9)
Number of fuel assemblies	121	157	193	193
Fuel length, feet (cm)	12 (365.8)	12 (365.8)	12 (365.8)	14 (426.7)
Fuel assembly array	16 x 16	17 x 17	17 x 17	17 x 17



The tertiary loop is the heat rejection loop where the latent heat of vaporization is rejected to the environment through the condenser cooling water. Depending on the specific site, this heat is released to a river, lake, ocean, or cooling tower system with the latter becoming the more common within the United States.

Use of a steam generator to separate the primary loop from the secondary loop largely confines the radioactive materials to a single building during normal power operation and eliminates the extensive turbine maintenance problems that would result from radioactively contaminated steam.

For general discussion purposes, a nuclear power plant can be considered to be made up of two major areas: a nuclear island and a turbine island. These are described below. Each is comprised of fluid, electrical, instrumentation

and control systems; electrical and mechanical components; and the buildings or structures housing them. There are also a number of shared fluid, electrical, instrumentation and control systems, as well as other areas of interconnection or interface.

### NUCLEAR ISLAND

The central group of systems and components within the nuclear island is known as the nuclear steam supply system or NSSS. Included within the NSSS are the Reactor Coolant System or RCS (in effect, the primary loop), auxiliary fluid systems and the major electrical, instrumentation and control systems required for operation and control of the nuclear systems. The nuclear island also includes related support systems and components as required for waste processing, fuel storage, and ventilation.

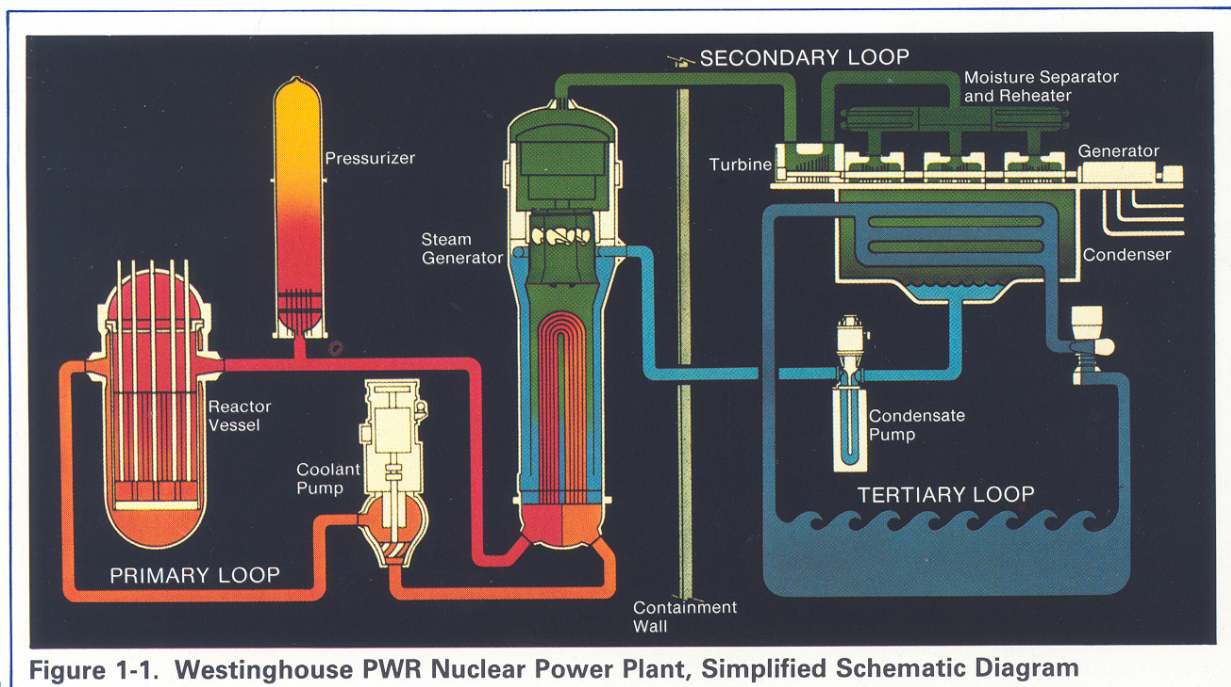

Figure 1-1. Westinghouse PWR Nuclear Power Plant, Simplified Schematic Diagram



## Reactor Coolant System

The central component of the reactor coolant system is a heavy walled reactor vessel which houses the nuclear core and its mechanical control rods as well as necessary support and alignment structures. The vessel is cylindrical in shape with a hemispherical bottom head and a flanged and gasketed upper head for access. It is fabricated of carbon steel, but all wetted surfaces are clad with stainless steel to limit corrosion.

The internal core support and alignment structures are removable to facilitate inspection and maintenance as is the alignment structure for the top mounted control rod drive mechanisms. Vessel inlet and outlet nozzles for the primary loops are located at a level well above the top of the fuel core.

The nuclear core is comprised of a number of fuel assemblies arranged in three regions to optimize fuel performance. While all fuel assemblies are mechanically identical, enrichment of the uranium dioxide fuel differs from assembly to assembly. In a typical initial core loading, three fuel enrichments are used. Fuel assemblies with the highest enrichments are placed in the core periphery, or outer region, and the groups of lower enrichment fuel assemblies are arranged in a selected pattern in the central region. In subsequent refuelings, one third of the fuel is discharged and fresh fuel is loaded into the outer region of the core. The remaining fuel is re-arranged in the central two thirds of the core in such a manner as to achieve optimum power distribution and fuel utilization.

Rod cluster control assemblies used for reactor control consists of absorber rods attached

to a spider connector which, in turn, is connected to a drive shaft. The absorber (control) rods are loaded with an absorber material that has a high affinity for neutrons. Above the core, control rods move within guide tubes which maintain alignment of the control rods with empty thimbles of certain fuel assemblies at particular locations in the core. The rod cluster control assemblies are raised and lowered by a drive mechanism on the reactor vessel head. The drive mechanism allows the rod cluster control assemblies to be released instantly when necessary for rapid reactor shutdown. Insertion of the assemblies during a trip is by gravity.

Westinghouse reactor coolant pumps are vertical, single-stage, mixed flow pumps of the shaft-seal type. A heavy flywheel on the pump motor shaft provides long coastdown times to preclude rapid decreases in core cooling flow during pump trips. Interlocks and automatic reactor trips ensure that forced cooling water flow is present whenever the reactor is at power. Additionally, two separate power supplies are available to the pump motor when the plant is at power.

Westinghouse steam generators are of a vertical U-tube design with an expanded upper section that houses integral moisture separation equipment to produce steam with a quality of at least 99.75 percent. Preheated feedwater enters the top of the unit, mixes with effluent from the moisture separators and then flows downward on the outside of the tube bundle. The feed is distributed across the bundle and then flows upward along side the heated tubes.

Reactor coolant piping, the reactor internals, and all of the pressure-containing and heat transfer

surfaces in contact with reactor water are stainless steel or stainless steel clad, except the steam generator tubes and fuel tubes, which are Inconel and Zircaloy, respectively.

An electrically heated pressurizer connected to one of the reactor coolant hot legs maintains reactor coolant system pressure during normal operation, limits pressure variations during plant load transients, and keeps system pressure within design limits during abnormal conditions. For example, a transient that could decrease system pressure is counteracted by flashing water within the pressurizer which is kept at saturation temperature by the automatic heaters. An increasing pressure transient is limited by spraying cooler water from the primary loop into the pressurizer steam space to partially collapse the steam bubble or by automatic operation of relief and safety valves.

### **Auxiliary Fluid Systems**

Normal and emergency operation of the reactor coolant system requires a number of support functions to: maintain water inventory, purify and treat primary coolant, remove residual heat following a plant shutdown, provide cooling water to pumps and motors, supply ventilation air, and provide emergency supplies of core cooling water. These functions are provided by auxiliary systems described later in this document.

### **Control**

Transient power behavior of a nuclear core is determined by a condition known as reactivity. For a core operating at a steady power level, the various factors which affect reactivity are balanced so that the net reactivity is zero. If the

net reactivity is positive, power level will increase and, conversely, decrease if reactivity is negative.

Power control of a PWR is based on balancing reactivity through the use of mechanical and chemical neutron absorbers and proper allowance for physical phenomena which influence reactivity. The principal natural phenomena which influence transient operation are the temperature coefficients of the moderator and fuel and the buildup or depletion of certain fission products.

Reactivity balancing may occur through the effects of natural phenomena or the operation of the reactor control system using either the rod cluster controls or chemical shim. A change in the temperature of either moderator or fuel, such as might occur due to an increase or decrease in steam demand, will add or remove reactivity and cause the power level to change until the reactivity change is balanced out.

Rod cluster control assemblies are used to follow fairly rapid load transients and for startup and shutdown. The chemical shim system uses a soluble neutron absorber, boron in the form of boric acid, which is inserted in the reactor coolant during cold shutdown, partially removed at startup, and adjusted in concentration during core lifetime to compensate for such effects as fuel consumption and accumulation of fission products which tend to slow the nuclear chain reaction.

The control system allows the plant to accept step load increases of 10 percent and ramp load increases of 5 percent per minute over the load range of 15 to 100 percent of full power subject to xenon limitations. Equal step and ramp load reductions are possible over the range of 100 to

15 percent of full power. Losses of reactor load up to 100 percent of rated power without reactor trip can be accommodated by steam dump to the condenser conjunct with the control system.

Complete supervision of both the nuclear and turbine-generator islands is accomplished from the plant control room.

### **Fuel Handling System**

The reactor is refueled with equipment which handles spent fuel under water from the time it leaves the reactor vessel until it is placed in a cask for shipment from the site. Water provides an economic and transparent radiation shield for the transfer of spent fuel, as well as a reliable coolant for removal of decay heat.

Fuel handling system equipment is located in two areas: (1) the reactor cavity which is flooded for refueling, and (2) the spent fuel pool which is external to the reactor containment and always accessible to plant personnel. The two areas are connected by a fuel transfer system which carries the fuel through a normally closed opening in the reactor containment.

Spent fuel is removed from the reactor vessel by a manipulator crane and placed in the fuel transfer system. In the spent fuel pool, the fuel is removed from the transfer system and placed into storage racks. After a suitable decay period, the fuel can be removed from storage and loaded into a shipping cask for removal from the site.

### **TURBINE ISLAND**

Systems and components of the turbine island can be considered the conventional part of the power plant with a rough but direct similarity to

the systems and components of a fossil fuel power plant. A qualification to this comparison is the significantly stricter specification on quality assurance and control that applies to even conventional parts of the nuclear plant due to the impact they may have on the nuclear systems.

Secondary and tertiary loops of the basic heat cycle are largely contained within the turbine island.

### **Steam Turbine**

The usual design of the steam turbine for an 1100 MWe PWR is an in-line combination of a single high-pressure turbine and three low pressure turbines, all of the double flow design where steam enters at the center and flows to both ends.

Steam admission to the double flow high-pressure turbine is controlled by four sets of governor valves with quick acting stop valves located ahead of them for rapid isolation. Four separate pipes convey the steam from the governor valves to the nozzle chambers. Thermal energy is converted to mechanical energy by expansion through a control stage (first stage) and a number of reaction stages. Steam pressure after the single control stage is measured and used as a load index for the reactor control system.

Upon leaving the last row of high-pressure blades, the steam has a significantly high moisture content which must be reduced before it enters the low-pressure turbines. High moisture content in steam adversely impacts efficiency and turbine maintenance. To accomplish moisture reduction, exhaust steam from the high-pressure turbine is passed through

a stage of moisture separation and reheat. Low-pressure turbines are provided with two or more moisture separator-reheater (MSR) units in parallel.

The wet steam is passed through the moisture separator section where moisture is removed in multiple vane chevron banks and then routed to a drain tank from where it is returned to the steam generators through the feedwater stream. The dried steam passes across tube bundles which are heated directly by high pressure extraction steam and main steam. The dried and slightly superheated steam passes to its associated low-pressure turbines through reheat stop and interceptor valves which operate in conjunction with the high-pressure turbine inlet stop valves to stop steam flow to all turbines in the event of a sudden loss of load condition.

### **Generator-Exciter**

The generator and exciter are directly driven by the steam turbine. The generator consists of a water cooled stationary stator with a hydrogen cooled rotor. The stator is mounted within the generator frame on a series of spring supports to minimize vibration noise and damage. The rotor, which provides the rotating electrical field, is cooled by blower-driven hydrogen gas at a pressure of several atmospheres. The hydrogen in turn is cooled by water. A subsystem maintains hydrogen purity and provides nitrogen purging when access to the generator is necessary.

The exciter is of the brushless design which does not require carbon brushes or collector rings. The exciter control circuitry is separately housed to provide easy maintenance.

### **Turbine Island Systems**

Figure 1-2 is a one-line diagram of the main steam, condensate, and feedwater systems which, along with condenser circulating water, are the principal systems of the turbine island. (For this discussion, the turbine-generator itself is not identified as a system.)

From the reactor containment building, the main steam system transports steam from the steam generators to the turbine island building where it is distributed. While the major usage of main steam is the turbine-generator, considerable amounts of steam are required for various auxiliary services such as feedwater pump turbines, steam jet air ejectors, reheaters, evaporators, and the like. With very few exceptions, all steam is condensed and returned to the cycle through either the condenser or the feedwater train.

The condenser is a large heat exchanger connected to the low-pressure turbine exhaust flange by an expansion joint. There are various locations for the condenser, usually below the turbine with its axis perpendicular to the turbine axis. The cooling water passes through tubes with the condensing steam flowing over the outside. Condensate is collected in a chamber called the hotwell from which condensate pumps take suction.

The design of the condenser includes special features to minimize in-leakage of cooling water and to prevent mixing of any in-leakage with the condensate. This is necessary to minimize the in-flow of contaminants to the steam generator where they can concentrate with deleterious effects.

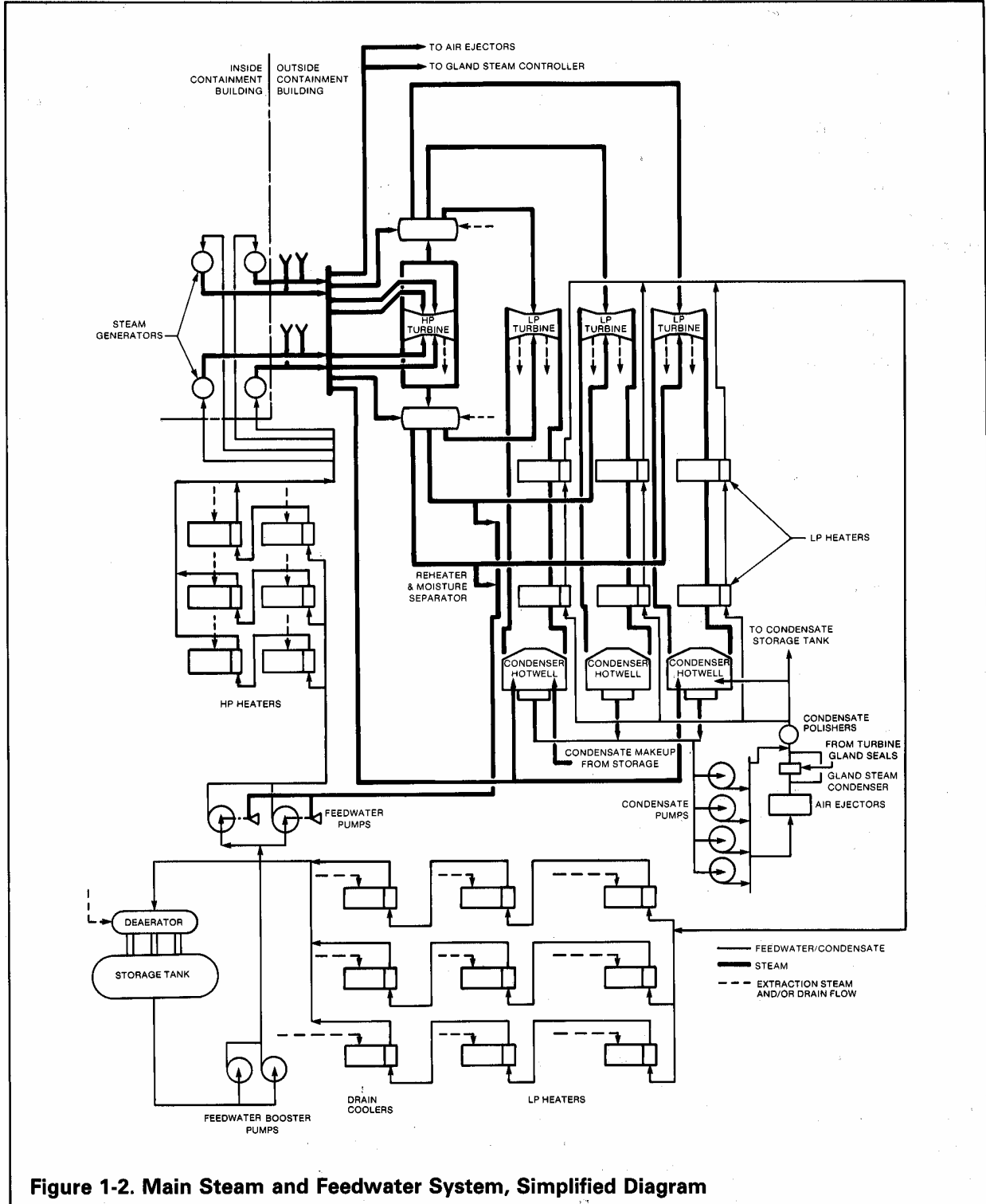

Figure 1-2. Main Steam and Feedwater System, Simplified Diagram

The condensate and feedwater systems return the condensed steam from the turbine condenser, and the drains from the regenerative feed heating cycle to the steam generators, while maintaining water inventories throughout the cycle. These systems automatically maintain the water level of the steam generators during steady-state and transient operation.

Sufficient feedwater storage capacity is maintained within the condensate/feed systems to accommodate mass transfer of fluid due to the expansion and contraction arising from thermal and pressure effects on the fluid inventory of the steam generators and condensate/feed systems during load changes.

## PLANT LAYOUT

A power station may be comprised of one or more individual power plants or units with some sharing of related support facilities such as maintenance machine shops and overall plant security. Layout designs are unique to each station as they must suit the conditions of each site, current regulations and standards, and the preferences of the utility as well as the judgments and prior experience of the architect-engineer.

A plan view of a representative layout for a two-unit station on a cooling lake is shown in Figure 1-3. A section through one of the units is shown in Figure 1-4.

The major structures are the turbine building, containment building, auxiliary building around the containment, and the several pump houses. Of particular note to this view is the radial orientation of the turbine building to the containment building. This orientation is common to modern layouts as it provides

additional protection from damage to the nuclear systems should there be a postulated failure of the turbine. Such failure could release large fragments of high energy content in directions roughly perpendicular to the turbine axis. While the containment building and other structures housing nuclear systems are quite strong and massive, the radial turbine orientation reduces the likelihood of any fragment ever hitting these buildings.

The containment building and contiguous buildings or compartments around it house the systems and equipment of the nuclear island.

The containment building is a cylindrical, steel lined, concrete pressure vessel with a hemispherical top closure and stepped flat bottom. The building encloses the reactor coolant system and has the principal function of containing the mass and energy of the reactor coolant in the postulated event of a rupture in the reactor coolant piping (i.e., an assumed loss-of-coolant accident.)

Design of the containment structure thus reflects a trade off between internal volume and design pressure. Current designs contain approximately two million cubic feet of free volume and are designed for an internal pressure of 60 psia (4 bar). Peak pressure for the maximum assumed loss-of-coolant accident is approximately 60 psia.

To improve seismic design, all of the nuclear island buildings or compartments are structurally connected and supported on a compartmentalized base mat. This unique Westinghouse design provides a large seismic "foot print" needed to meet severe seismic criteria and develops strength comparable to that of a solid base mat. It also provides a spacious and

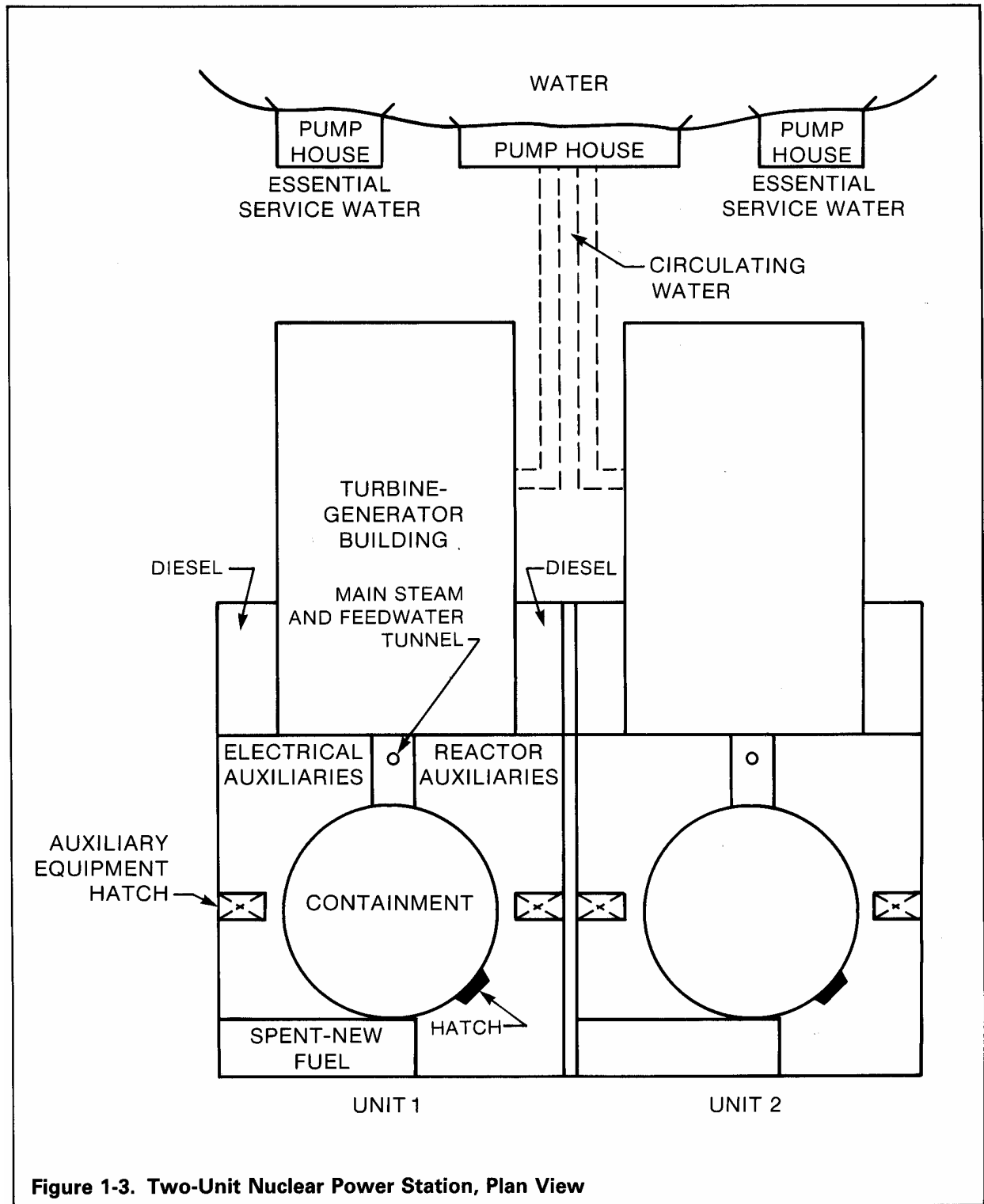

Figure 1-3. Two-Unit Nuclear Power Station, Plan View



and efficient layout utilizing what would otherwise be the wasted volume of a solid base mat. Access is provided to the bottom of the containment building which facilitates connection of auxiliary systems to the four piping loops of the reactor coolant system while maintaining good physical separation.

The auxiliary structure around the containment building houses redundant electrical and

fluid auxiliary systems associated with the reactor coolant system. A separate compartment on the common base is for storage of new and spent fuel.

The turbine building houses the turbine-generator and the other major components and systems of the turbine island.

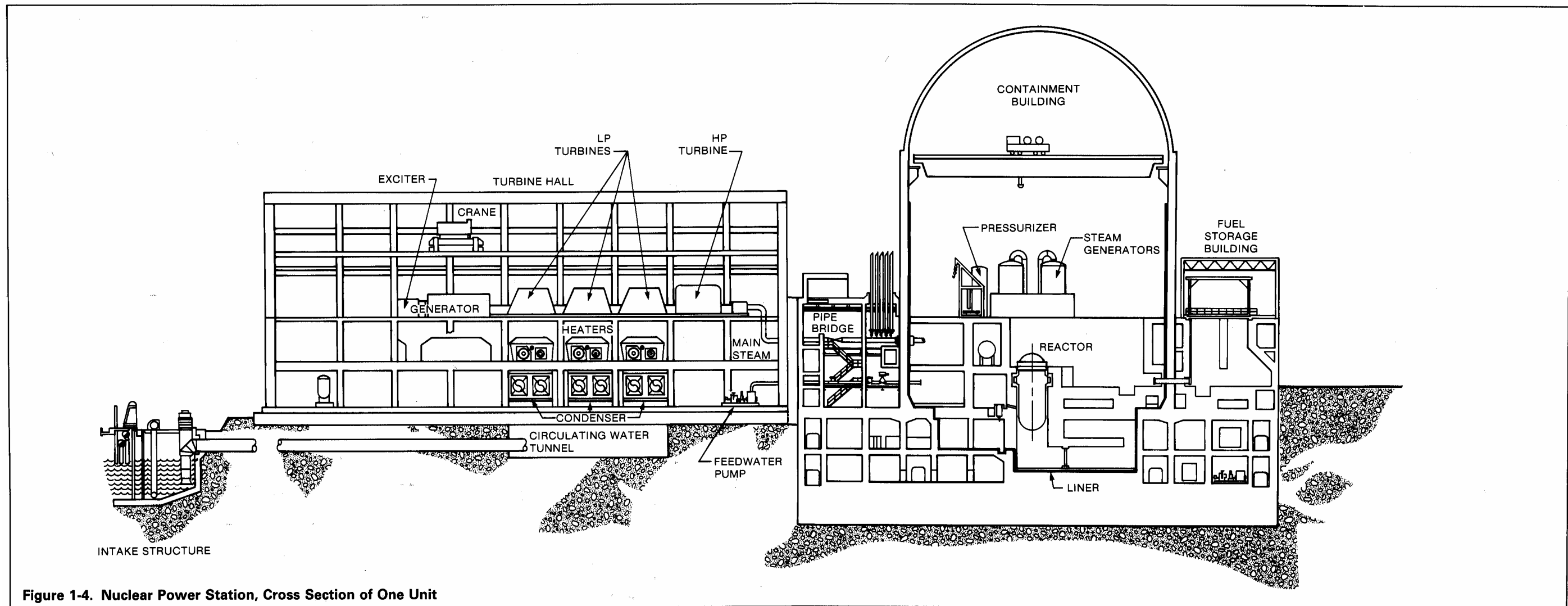

Figure 1-4. Nuclear Power Station, Cross Section of One Unit



# **chapter 2**

## **reactor core and nuclear characteristics**

## INTRODUCTION

The function of a nuclear power reactor is to generate heat at the rate demanded. In a Westinghouse pressurized water reactor (PWR) this is done with a reactor core (Figure 2-1) consisting of Zircaloy-clad slightly enriched uranium dioxide fuel rods in canless assemblies (Figures 2-2 and 2-3), various internal structures, reactivity control components, and core monitoring instrumentation. The core is located in a reactor vessel through which flows the pressurized light water which acts both as moderator and coolant. The reactor system is designed to operate at the licensed power rating with sufficient margins to allow for the most severe design basis transients\* without damage to the core.

This chapter describes the components of the nuclear core and provides supporting information concerning their capability to perform intended functions under all normal operational modes, including both steady-state and transient conditions. Table 2-1 shows typical parameters for a Westinghouse PWR system core.

The reactor core is of the multi-region type. In the first reactor cycle, fuel assemblies having the highest enrichment are placed on the periphery of the core; those with lower enrichments are mixed in the central region of the core

\* These transients provide an outside envelope of extremely unlikely accident conditions including the double ended guillotine pipe break in a reactor coolant system cold leg.

**TABLE 2-1  
TYPICAL REACTOR CORE PARAMETERS**

	2-Loop Plant	3-Loop Plant	4-Loop Plant
Total heat output, MWt	1882	2785	3411
Heat generated in fuel, %	97.4	97.4	97.4
Nominal system pressure, psia (bar)	2250 (155)	2250 (155)	2250 (155)
Total coolant flow rate, lb/hr (kg/sec)	~71.03 x 10 <sup>6</sup> (8950)	~109.0 x 10 <sup>6</sup> (13734)	~138.4 x 10 <sup>6</sup> (17438)
Coolant temperature			
Nominal inlet, °F (°C)	549.9 (287.7)	557.0 (291.7)	557.5 (291.9)
Average rise in vessel, °F (°C)	66.2 (36.8)	62.9 (34.9)	61.0 (33.9)
Outlet from vessel, °F (°C)	616.1 (324.5)	619.9 (326.6)	618.5 (325.8)
Equivalent core diameter, ft (cm)	8.4 (256)	9.98 (304)	11.06 (338)
Core length, between fuel ends, ft (cm)	12.0 (365.8)	12.0 (365.8)	12.0 (365.8)
Fuel type	16 x 16 Std	17x17 OFA	17x17 OFA
Fuel weight, uranium in core, kg	49,702	66,411	81,639
Number of fuel assemblies	121	157	193

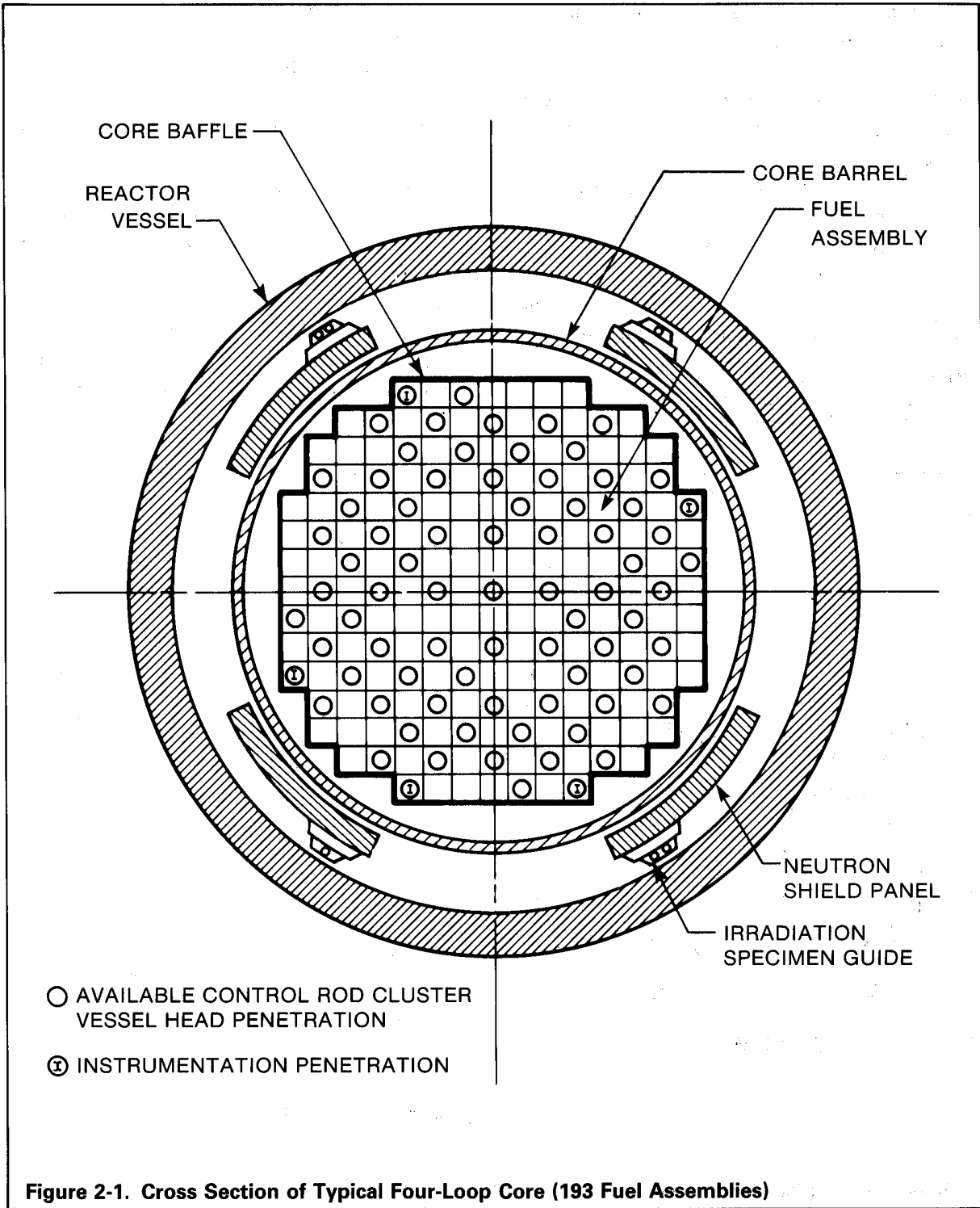

in a pattern that yields the most uniform power distributions.

At the time of refueling, the central region fuel assemblies having the lowest enrichments are removed and the outer region fuel assemblies are shifted inward in accordance with a selected reload pattern. Fresh fuel is then added at the core periphery and in some cases, at adjacent inboard locations. This cycling method has had widespread usage because it results in the most uniform power and burnup distributions.\*\*

\*\*Low leakage loading patterns use a different fuel loading scheme in which fresh fuel with burnable absorbers are located in the central region.

Reactor control is provided by neutron-absorbing control rod clusters (Figure 2-3) and by a neutron absorber (boric acid) dissolved in the reactor coolant. The control rod clusters are used to follow load changes, to provide reactor trip capability, and to furnish control for slight deviations in reactivity due to temperature. In event of a reactor trip, the control rods fall into the core by gravity. The concentration of the boric acid is varied during the life of the core to compensate for changes in reactivity that occur with fuel depletion, as well as to compensate for the reactivity associated with the xenon transients arising from power level changes.

## FUEL PELLETS

The basic component of the core is the cylindrical fuel pellet (Figure 2-4). It is composed of slightly enriched uranium dioxide powder that is compacted by cold pressing and then sintered to attain the required density. The sintered uranium dioxide is chemically inert at reactor temperatures and pressures. The consequences of any accidental breach of the cladding are minimized by the ability of the uranium dioxide lattice to retain fission products and to resist deterioration caused by high temperature water. The slightly dished ends of each pellet permit axial expansion at the center of the pellets.

## FUEL RODS

Uranium dioxide pellets are inserted into a Zircaloy-4 tube, and each end of the tube is sealed by welding on an end plug to form a fuel rod. The pellets are prevented from shifting during handling and shipment by a compression spring located between the top of the fuel pellet stack and the top end plug. Refer to Table 2-2 for fuel rod parameters.

To increase fuel rod reliability, Westinghouse developed the technology for using pre-pressurized fuel rods. Fuel rod pre-pressurization which reduces fuel and cladding mechanical interaction significantly reduces the

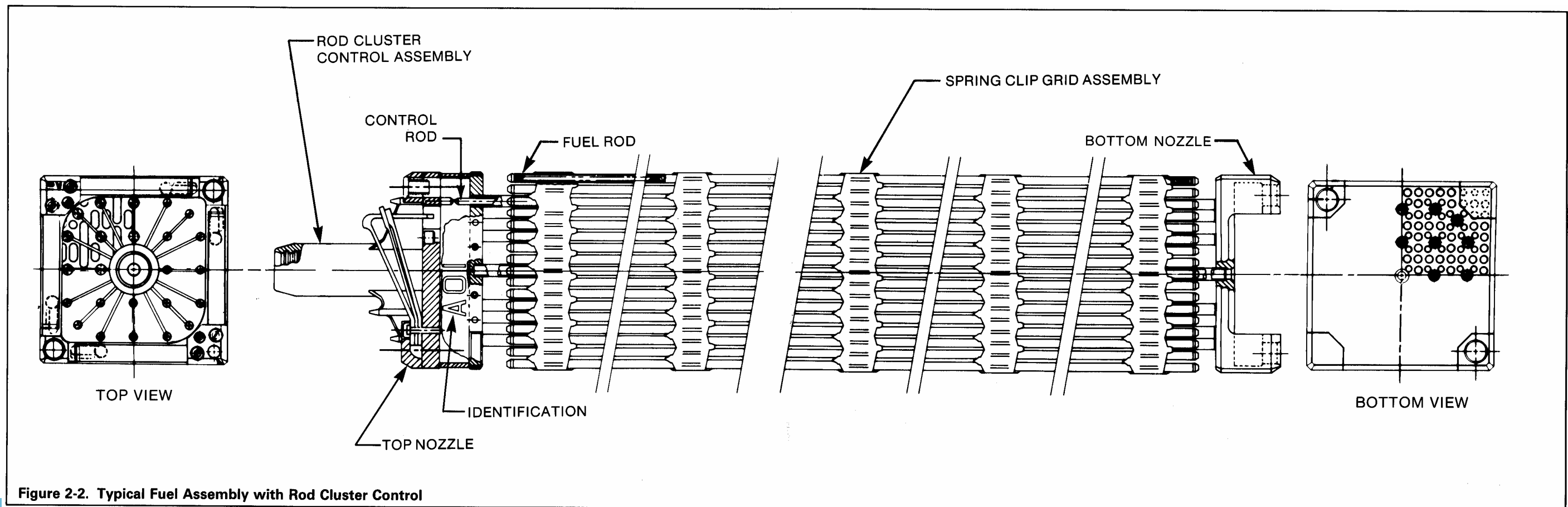

Figure 2-2. Typical Fuel Assembly with Rod Cluster Control

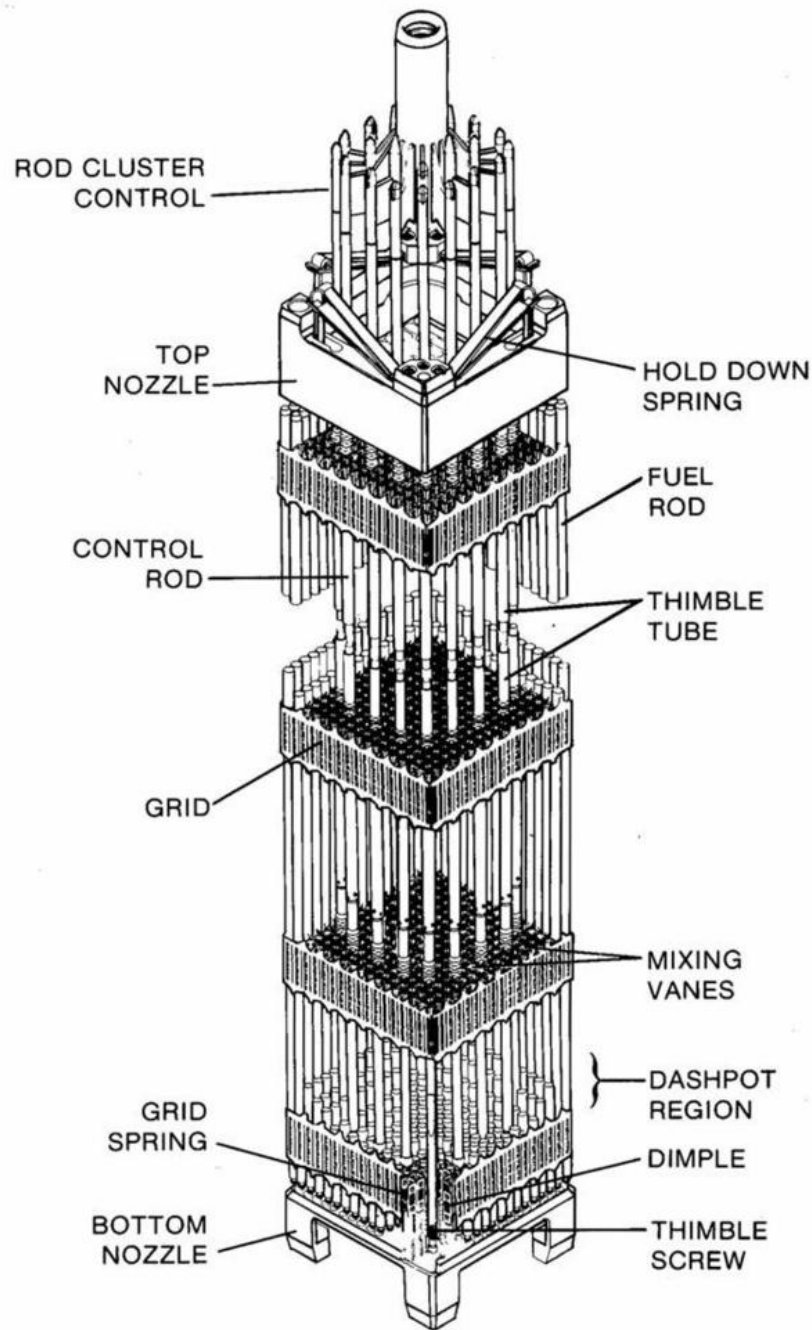

Figure 2-3. Cutaway of 17 x 17 Optimized Fuel Assembly with RCC

number and extent of cyclic stresses and strains experienced by the cladding. The result is a marked extension of the fatigue life margin of the cladding with enhanced cladding reliability.

## FUEL ASSEMBLIES

A square array of fuel rods structurally bound together constitutes a fuel assembly. Control rod guide thimbles replace fuel rods at selected spaces in the array and are fastened to the top and bottom nozzles of the assembly. Spring clip grid assemblies are fastened to the guide thimbles along the height of the fuel assembly to provide support for the fuel rods. The fuel rods are contained and supported, and the rod-to-rod centerline spacing is maintained within this skeletal framework. A cross section of three typical fuel assemblies is shown in Figure 2-5.

The bottom nozzle of the fuel assembly controls the coolant flow distribution and also serves

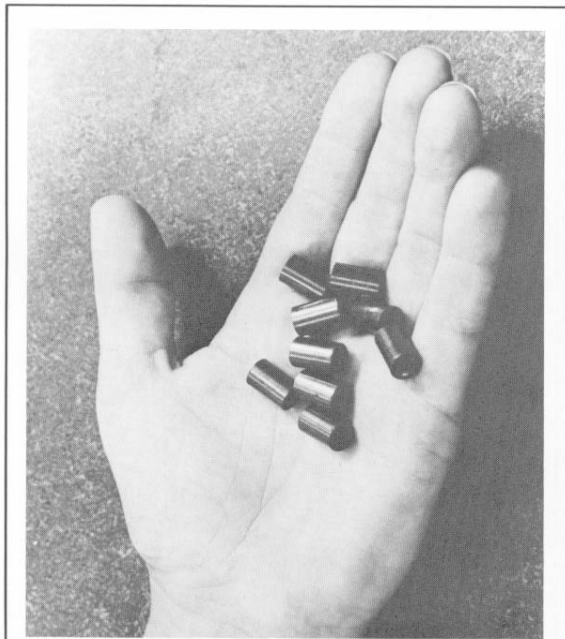

Figure 2-4. Fuel Pellets

as the bottom structural element. The top nozzle functions as the fuel assembly upper structural element and forms a plenum space where the heated reactor coolant is mixed and directed toward the flow holes in the upper core plate.

The spring clip grids (Figure 2-6) provide support for the fuel rods in two perpendicular directions. Each rod is supported at six points in each cell of the grid. Four support points are fixed: two on one side of the grid strap, and two similarly located on the adjacent side. Two more support points are provided by spring straps located opposite the fixed points. Each spring strap exerts a force on the fuel rod such that lateral fuel rod vibration is restrained. Because the fuel rods are not physically bound to the support points, they are free to expand axially

**TABLE 2-2  
FUEL ROD PARAMETERS  
(Four-Loop Plant)**

Fuel rod length	12 ft (365.8 cm)
Outside diameter	0.360 in. (0.914 cm)
Cladding thickness	0.0225 in. (0.0572 cm)
Cladding material	Zircaloy-4
Diametrical gap	0.0062 in. (0.0157 cm)
Pellet diameter	0.3088 in. (0.7844 cm)
Lattice pitch	0.496 in. (1.260 cm)
Rods array in assembly	17 x 17
Rods in assembly	264
Total number of fuel rods in core	50,952



to accommodate thermal and radiation induced growth.

Two types of grid assemblies are employed. One type features mixing vanes that project from the edges of the straps into the coolant stream to promote mixing of the coolant in the high heat region of the fuel assemblies. The other, a non-mixing type of grid, is located at the bottom and top ends of the assembly. The outside straps on all grids contain vanes which aid in guiding the grids and fuel assemblies past projecting surfaces during fuel handling or while loading and unloading the core.

All fuel assemblies employ the same basic mechanical design. While all assemblies are capable of accepting control rod clusters,\* these

\* The term control rod cluster is also referred to as rod cluster control.

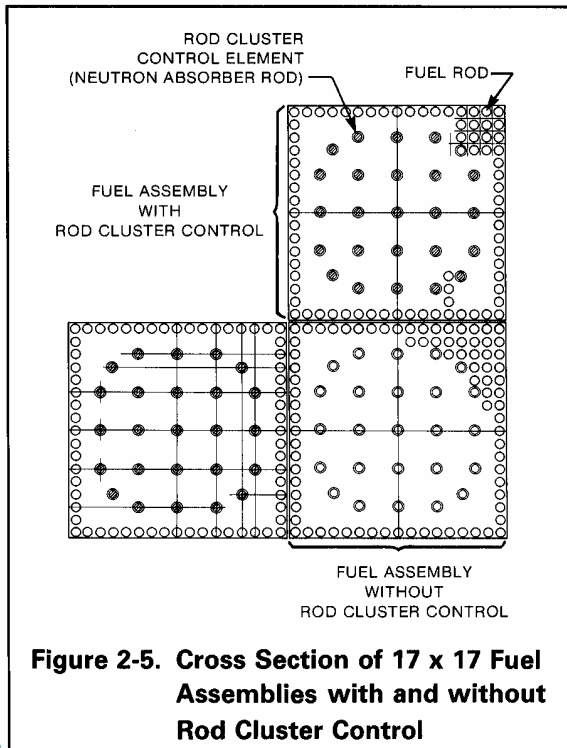

are not used at every core location. Selected fuel assemblies have neutron sources or burnable absorber rods installed in the control rod guide thimbles. Fuel assemblies not containing either control rod clusters, source assemblies, or burnable absorber rods, are fitted with plugs in the upper nozzle to restrict the flow through the vacant control rod guide thimbles. This plug includes an end-flow mixing device to assure that these fuel assemblies have approximately the same coolant flow as those containing control rod clusters.

The Westinghouse fuel assembly design provides optimum core performance by minimizing neutron absorption in structural materials and maximizing heat transfer capabilities. Mixing vane grids increase the heat transfer capability of the fuel rods. High fuel utilization is achieved by minimizing the parasitic

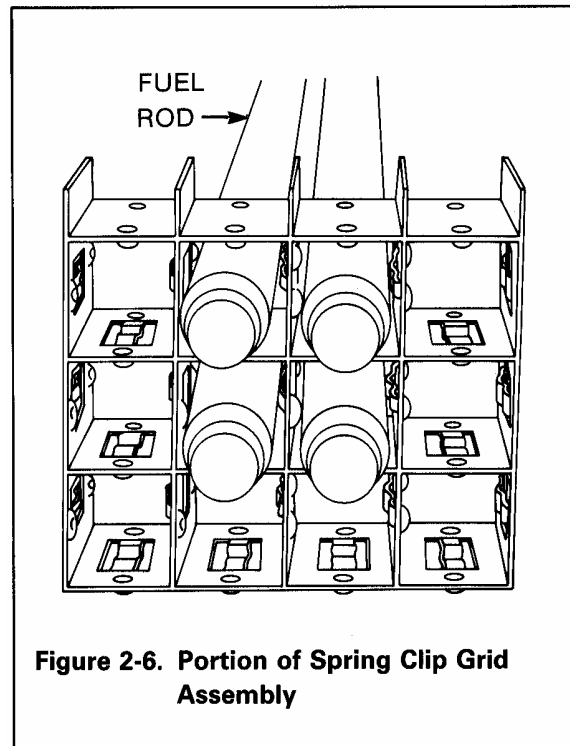

absorption of neutrons in the core. In the Westinghouse assembly design, the only structural materials in the fuel region are the spring clip grids, Zircaloy control rod guide thimbles, and Zircaloy fuel cladding. Zircaloy is used because it absorbs relatively few neutrons and has good heat transfer properties.

To assure that fuel pellets, tubes, rods, and finished assemblies meet a high standard of excellence, many inspections and tests are performed on both the raw material and the unfinished product. These tests and inspections include chemical analysis, tensile testing, corrosion tests, dimensional inspection, X-ray, ultrasonic tests, and helium leak tests.

## **ROD CLUSTER CONTROL ASSEMBLIES**

Rod cluster control (RCC) assemblies are used for reactor startup or shutdown, to follow load changes, and to control small transient changes in reactivity.

The control elements of a RCC assembly consists of cylindrical neutron absorber rods (control rods), having approximately the same dimensions as a fuel rod and connected at the top by a spider-like bracket to form rod clusters (Figures 2-2 and 2-3).

The control rods, which are stainless steel tubes encapsulating a hafnium absorber material, extend the full length of the core when fully inserted. Full length RCCs provide operational reactivity control and can shut the reactor down at all times, even with the most reactive RCC stuck out of the core.

Each RCC is coupled to its drive shaft, which is actuated by a separate magnetically actuated

drive mechanism mounted on the reactor vessel head. The RCCs are arranged into groups and electrically interconnected so that the entire group moves together. Reactivity of the core is changed by raising or lowering a group in the core.

Each control rod of a RCC moves vertically in its own tubular guide thimble. Located symmetrically within fuel assemblies, these thimbles replace fuel rods within the fuel assembly lattice. The thimbles: 1) act as guides for the control rods and 2) serve as dashpots for slowing control rod motion during reactor trip. In their fully withdrawn position, the control rods do not leave the upper end of the guide thimbles. This assures that the rods are always properly aligned, and reduces reactor coolant bypass through the thimbles. The thimbles are perforated over a portion of their length to allow passage of water and permit rapid rod insertion. The lower end of each guide tube is closed and acts as a dashpot to decelerate the control rod at the end of its drop under reactor trip.

The Westinghouse rod cluster control design contributes to core performance improvement by providing a relatively homogeneous means of control. When the control rods are withdrawn from the core, the small resulting water gaps cause no significant power peaking.

## **CORE THERMAL-HYDRAULIC DESIGN**

The basic objective of the core thermal-hydraulic design is to ensure that energy generated in the fuel is transferred to the coolant while maintaining fuel rod temperature limits even under the most severe anticipated or design basis transient conditions. To maintain fuel rod



integrity and prevent the release of fission products, the fuel cladding must be prevented from overheating under all operating or postulated accident conditions. This is accomplished by preventing Departure from Nucleate Boiling (DNB), because DNB causes a large decrease in the heat transfer coefficient from the cladding to the coolant, thereby resulting in high fuel rod temperature since the rate of heat transfer must be maintained. DNB occurs when the fuel rod surface and coolant temperatures are high enough to create a vapor blanket around the fuel rod. This vapor blanket acts like an insulator, reducing the heat transfer coefficient to the coolant when compared to the heat transfer coefficient at lower heat fluxes and/or coolant temperatures.

The measure of confidence that DNB will not occur is the DNB ratio, defined as the ratio of the predicted heat flux at DNB to the actual local heat flux. In reactor core design, both the heat flux associated with DNB and the location of the minimum DNB ratio are important. To predict the local DNB heat flux Westinghouse uses empirical design correlations which include nonuniform heat flux effects, and the upstream effects of inlet enthalpy and core geometry.

Three-dimensional nuclear, thermal, and hydraulic design analyses are used to determine the core power capability such that the allowed overall power distribution peak does not exceed the linear power density limit or violate the minimum DNB ratio at any time during a fuel cycle. Linear power density limits are determined by the peak cladding temperature permitted in the postulated double ended break of a cold leg pipe. The limiting axial power distribution may not occur simultaneously with

the maximum radial power peak. Given a radial distribution, the limiting condition on power is determined by the shape of the axial distribution, and not by a fixed peak-to-average ratio of power density. For example, a small peak in the top of the core on a relatively flat power distribution may be DNB-limited. In the bottom of the core, a much greater peak is allowable and may be limited by linear power density.

## REACTIVITY CONTROL

### Operational Reactivity Control

Reactivity control is provided by the neutron absorbing control rods and a soluble chemical neutron absorber (boric acid) in the reactor coolant. The boric acid concentration is varied to control slower reactivity changes such as fuel depletion and fission product buildup; cold to hot, zero power reactivity change; reactivity changes produced by intermediate-term fission products, such as xenon and samarium\*; and burnable absorber depletion.

The four-loop reactor core utilizes about 53 full length RCC assemblies which provide reactivity control for power defect compensation (reactivity changes due to temperature changes with power), for rapid shutdown, for reactivity changes due to coolant temperature changes in the power range, and for reactivity changes due to void formation. The number and placement of control rods are based on the following considerations:

---

\* After any change in core power, the concentrations of these isotopes exhibit transient behavior before reaching equilibrium at the new power level. This is particularly so in the case of xenon: following a power reduction, xenon initially builds up for about seven hours, and then slowly decays.

**Doppler Defect** – This defect is due to an increase in width of uranium-238 resonance peaks in the epithermal energy range. This defect is most noticeable over the range of zero to full power, since the effective neutron temperature increases by about 1000°F (540°C) as the average physical pellet temperature is increased with heat generation.

**Variable Average Moderator Temperature** – The average moderator temperature of the core is programmed to change linearly with power level from the no load value of 547°F (286°C) (based on steam generator shell side design pressure) to the full load value as determined by steam generator and turbine characteristics (allowable steam pressure, heat transfer, tube fouling, etc.). The design full load average temperature is about 571°F (300°C). At the beginning of life, the effect on reactivity is small since the moderator temperature coefficient is small. At the end of life, the coefficient is substantially more negative due to depletion and removal of shim boron, and the effect on reactivity addition is greater.

**Redistribution** – The temperature rise across the core changes with power level. Consequently, the coolant density in the core varies with power level. At the beginning of life, the effect on reactivity from coolant density changes is small, and so the effect on the power distribution is small. The moderator temperature coefficient of reactivity becomes more and more negative as the fuel depletes. At the same time, the fuel in the top half of the reactor becomes less reactive than the fuel in the bottom half because of the temperature difference. This change is so slow that fuel depletion acts to keep the power distribution flat by preferentially depleting the fuel at the bottom of the core. The

cumulative effect is a flat power distribution at the end of life with full-power operation.

The sum of the above three effects, Doppler, variable average moderator temperature, and redistribution is termed the power defect. The power defect is fairly linear with power level and lifetime, and changes because of boron concentration and depletion.

**Bite** – The control rod bite is the amount of insertion into the core to maintain a minimum reactivity ramp rate. It reflects the ability of the control system to allow a five percent per minute ramp change or a ten-percent step change in the power level. The insertion is necessary because the differential rod worth or neutron capability is near zero at the top and bottom ends of the core.

**Rod Insertion Allowance** – The lead control groups are operated so as to compensate for small periodic changes in boron concentration, system pressure, axial power distribution, and coolant temperature. The maximum rod insertion allowance is established in conjunction with these considerations with provisions for adequate shutdown margin.

**Void Content** – The void content of the core is about one-half of one percent, and is due to local or statistical boiling.

**Steam Break Shutdown** – This is the required shutdown reactivity to minimize the consequences of a postulated secondary side steam line rupture. The core temperature decreases rapidly in the event of a steam line rupture, causing an increase in reactivity in the presence of a negative moderator temperature coefficient. The time taken to return to criticality

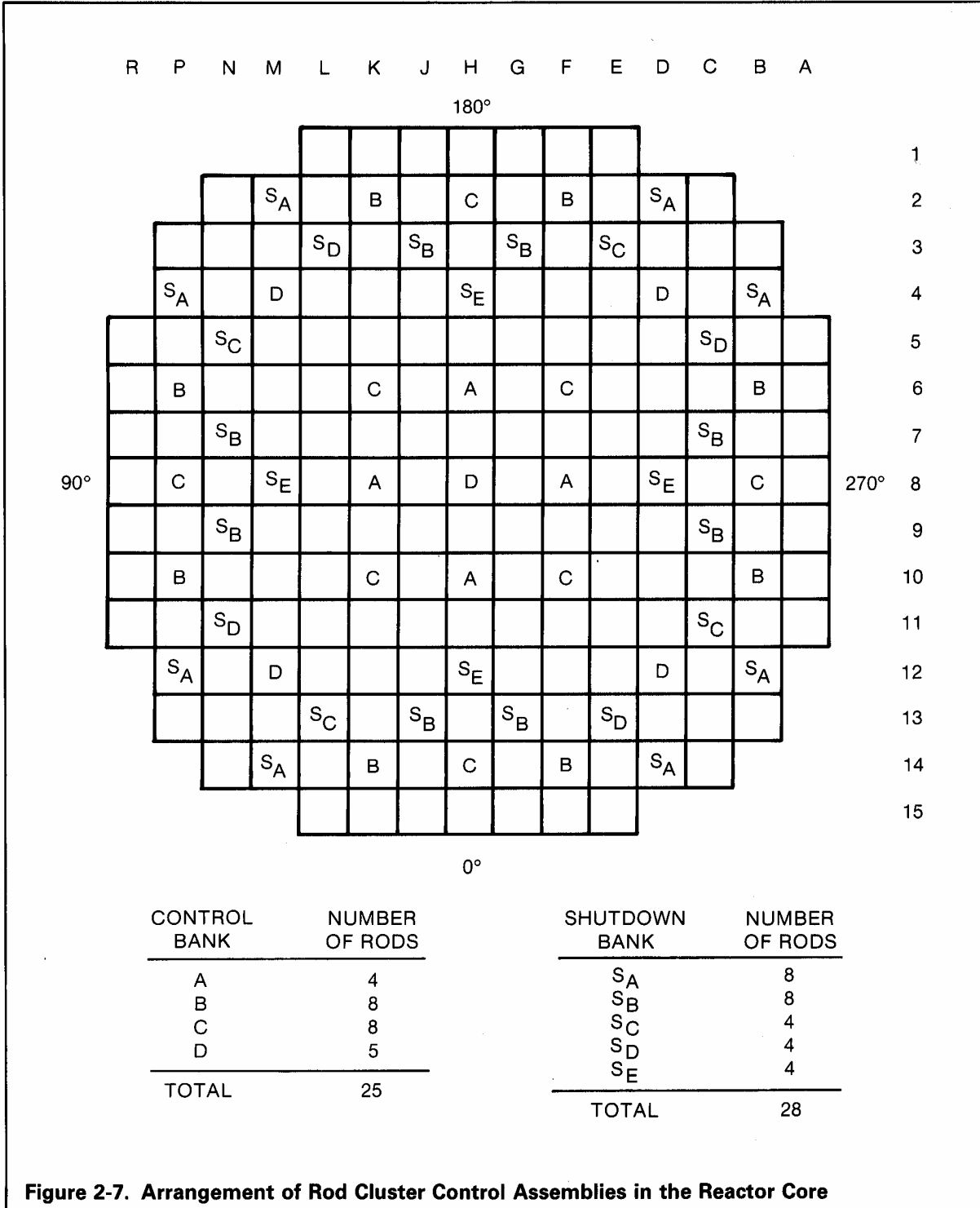

**Figure 2-7. Arrangement of Rod Cluster Control Assemblies in the Reactor Core**

after system shutdown is determined by the amount of shutdown or negative reactivity available.

The first six items above are classified as control group requirements, while the last is a shutdown requirement. The control groups are selected to be symmetrical, worth about one-percent in reactivity, to yield acceptable radial power distributions in their proper insertion sequence, and to give an acceptable transient in the hypothetical instance of a rod cluster ejection. The overall pattern of rods is selected to give the maximum reactivity worth with the most reactive rod cluster stuck in its full-out position. A typical rod cluster control arrangement in the reactor core is shown in Figure 2-7.

### Burnable Absorber

Of the 193 fuel assemblies contained in a four-loop reactor first core, approximately 65 are of a low enrichment (2.10 weight/percent uranium-235), 64 are an intermediate enrichment (2.60 weight/percent uranium-235), and 64 are a high enrichment (3.10 weight/percent uranium-235). The low and intermediate enrichment assemblies are arranged in a checkerboard pattern in the central portion of the core while the high enrichment assemblies are arranged about the periphery of the core (Figure 2-8).

The first fuel cycle normally contains more excess reactivity than subsequent cycles, due to the loading of all fresh (unburned) fuel. If soluble boron were the sole means of control, the concentration would be on the order of 1700 ppm and the moderator temperature coefficient would be on the order of +7 pcm/°F (a 15°F

(-9.5°C) increase in moderator temperature creates 0.001 reactivity increase). Since a large positive coefficient is undesirable, a reduction of the amount of control to be provided by chemical shim is accomplished by placing aluminum oxide-boron carbide burnable absorber material in the core. This material is depletable in the same fashion as uranium-235. Figure 2-9 shows the approximate burnable poison locations in a four-loop core, and Figure 2-10 shows the reduction in chemical shim brought about by the presence of this burnable absorber. As the fuel and burnable poison deplete, the power will shift toward the center of the core, and this shift must be accounted for in design calculations. At the end of life, the power distribution is again quite uniform.

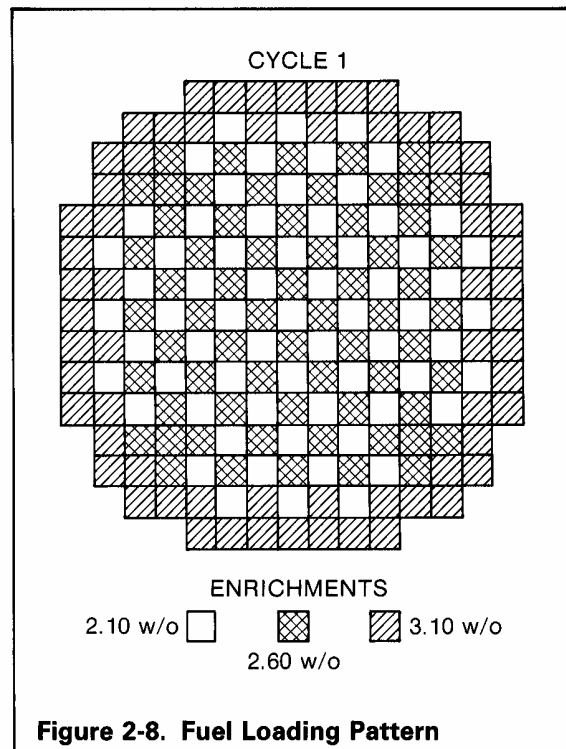

**Figure 2-8. Fuel Loading Pattern**

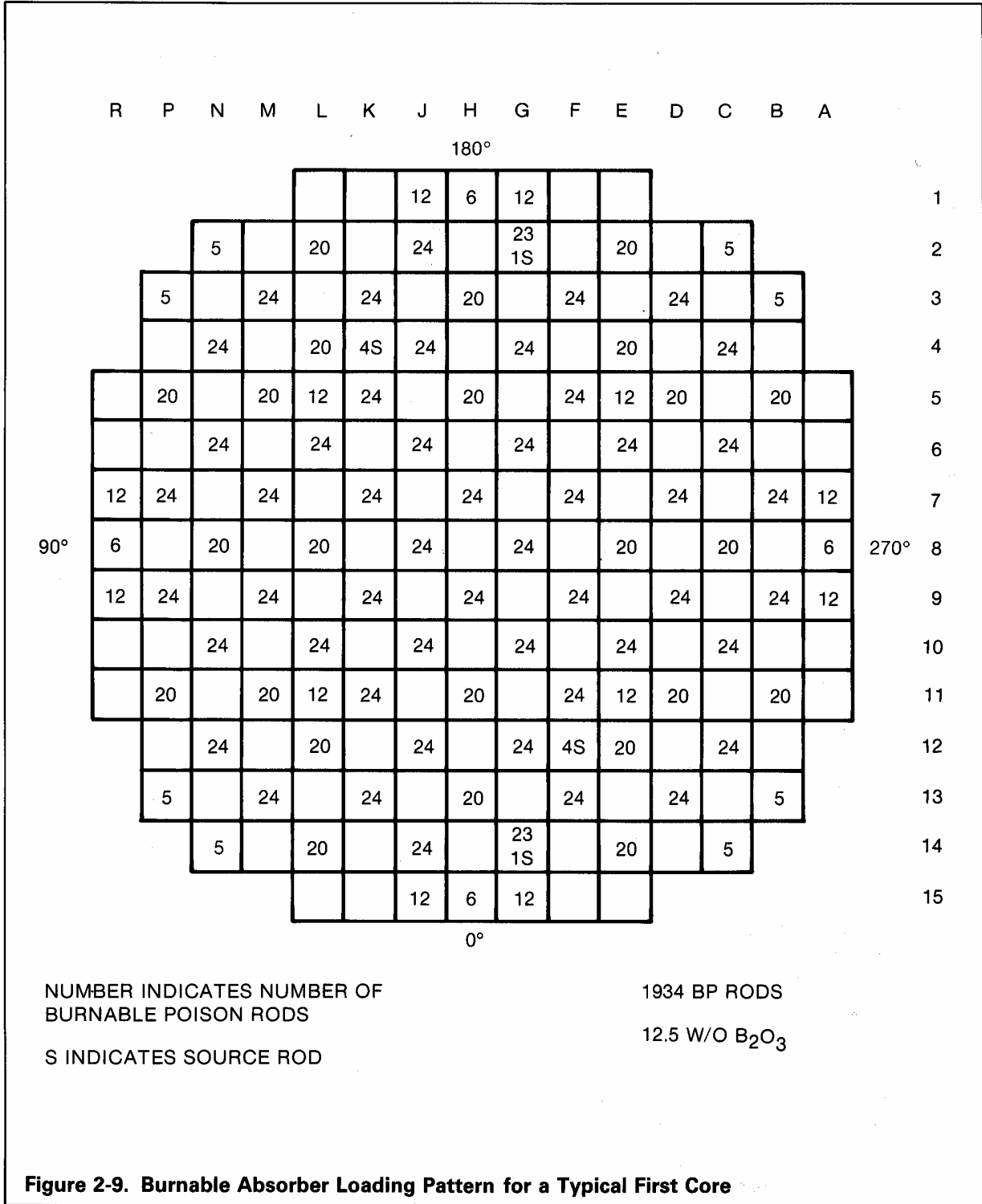

## REACTOR STARTUP NEUTRON SOURCES

Reactor startup neutron sources must be used because of fuel configuration and the initially low core activity.

Neutron sources are of two types: 1) a primary source, which is active for initial reactor startup and startup early in the life of the first core, and 2) a secondary source, used for later startup of the reactor and which is activated during the operation of the reactor. The primary sources normally are a californium isotope. The secondary sources contain a mixture of antimony and beryllium (Sb-Be).

The primary and secondary sources are similar to a control rod in mechanical construction. Both types of source rods are clad in stainless steel. The secondary source rods contain Sb-Be pellets which are not initially active. The primary source rods contain sealed capsules of source material at a specified axial position. Cladding encapsulation is completed by seal-welding the end plugs.

The specific core location of the sources is determined during final design of the core to assure adequate neutron flux at the source range detectors at all times.

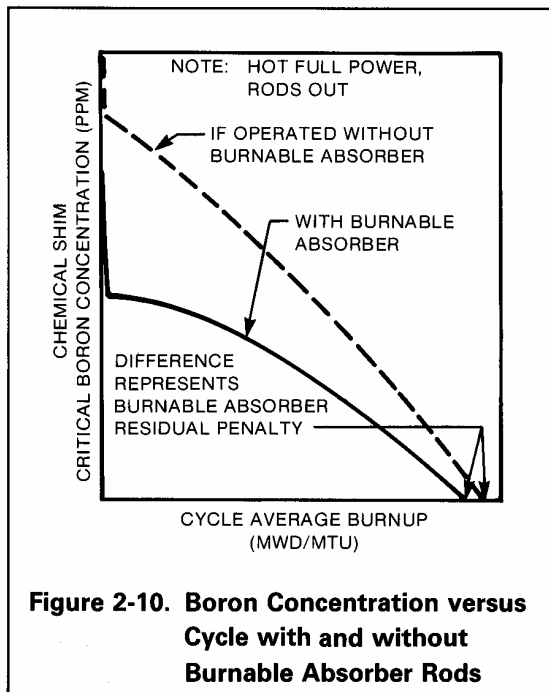

# **chapter 3**

## **reactor coolant system**

The Reactor Coolant System (RCS) consists of similar heat transport loops (two-loop, three-loop, or four-loop) connected in parallel to the reactor vessel. Figure 3-1 is a schematic flow diagram (one-loop) of the RCS. Each loop contains a reactor coolant pump and a steam generator. The RCS also includes a pressurizer, safety and relief valves, a pressurizer relief tank,

and connecting piping. Control rod drive mechanisms mounted on top of the reactor vessel operate the control rod clusters that are used for reactor startup, load changes, and shutdown.

These major components of the RCS are described in the following sub-chapters.

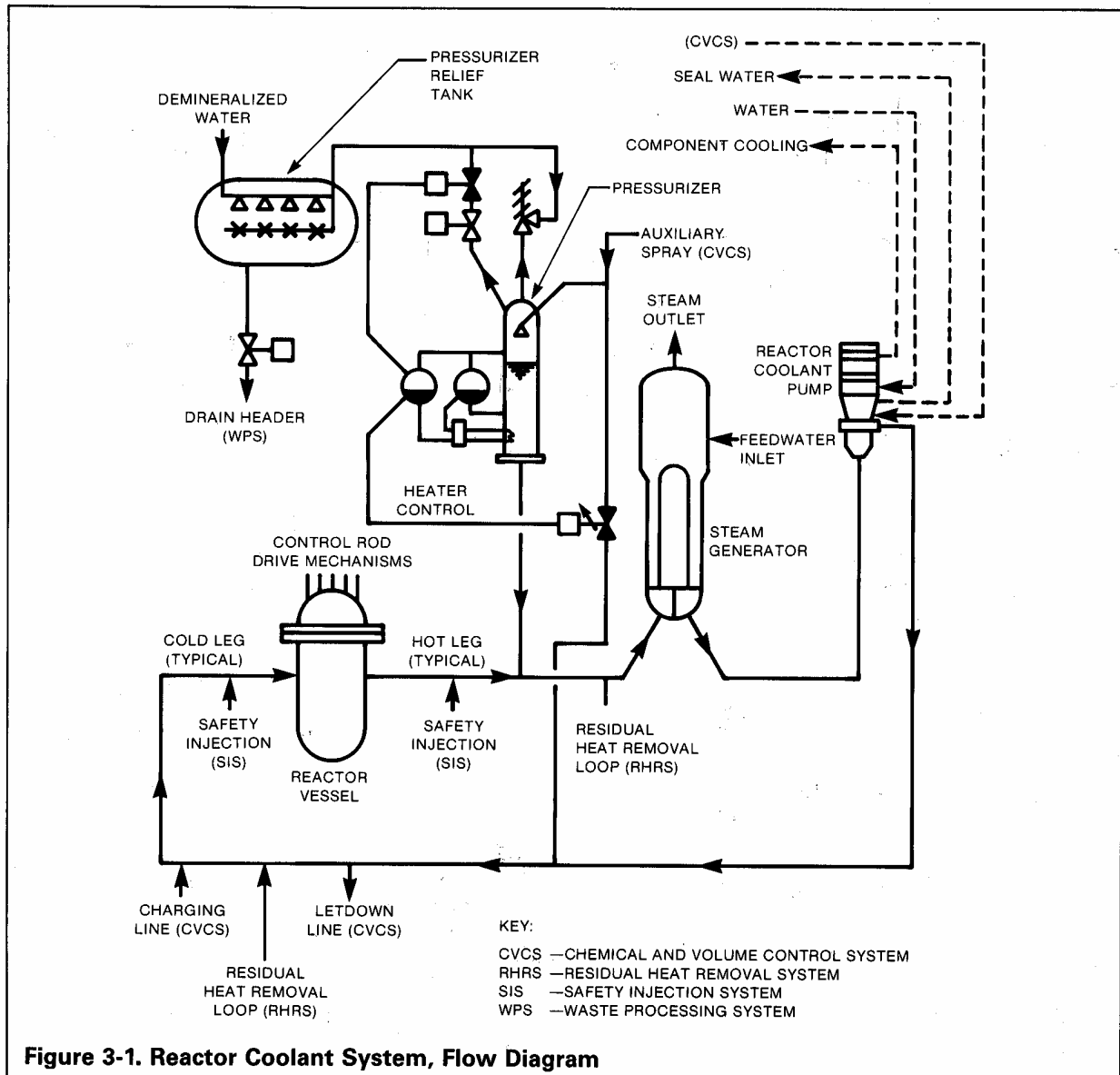



# chapter 3.1

## reactor vessel and internals

The reactor vessel, as principal component of the Reactor Coolant System (RCS) contains the heat-generating core and associated supports, controls, and coolant circulating channels. Outlet and inlet nozzles provide for the exit of the heated coolant and its return to the vessel for recirculation through the core.

### REACTOR VESSEL

The reactor vessel (Figure 3.1-1) is cylindrical with a hemispherical bottom head and a flanged and gasketed removable upper head. The vessel contains the core, core support structures, rod control clusters, neutron shield panels, and other parts directly associated with the core. Inlet and outlet nozzles are located at an elevation between the head flange and the core. The vessel is designed and manufactured to the requirements of Section III of the ASME Boiler and Pressure Vessel Code. Principal parameters are listed in Table 3.1-1.

The body of the vessel is low alloy carbon steel. Inside surfaces in contact with coolant are clad with a minimum of 1/8-inch (3 mm) austenitic stainless steel to minimize corrosion.

The vessel is supported by steel pads integral with the coolant nozzles. The pads rest on steel

base plates atop a support structure attached to the concrete foundation.

Thermal expansion and contraction of the reactor vessel are accommodated by sliding surfaces between the support pads and the base plates. Side stops on the base plates keep the vessel centered and resist lateral loads, including all piping loads.

Neutron shield panels, attached to the lower portion of the core barrel in high flux regions, protect the vessel by attenuating the gamma radiation and the fast neutron flux that escapes from the core.

The removable upper head of the reactor vessel contains a bolting flange employing studs and nuts. Hydraulic tensioning of the studs permits uniform nut loading. An elongation gauge is employed to facilitate uniform loading.

Two hollow, metallic O-rings form a pressure-tight seal in concentric grooves in the head flange. The O-rings are self-energized by permitting Reactor Coolant System pressure to act on the inside of the O-rings through slots in the O-rings. Because the O-rings are retained in the reactor vessel head by clips so that they will be removed with the head, they can be replaced outside the refueling cavity. The double O-ring seal and flange design permits vessel heatup and cooldown without leakage past the second O-ring. The space between the two O-rings is tapped and piped to a temperature indicator and then to the Reactor Coolant System drain tank. If the inner O-ring fails to seal, leakage of reactor coolant will give a high-temperature indication and alarm.

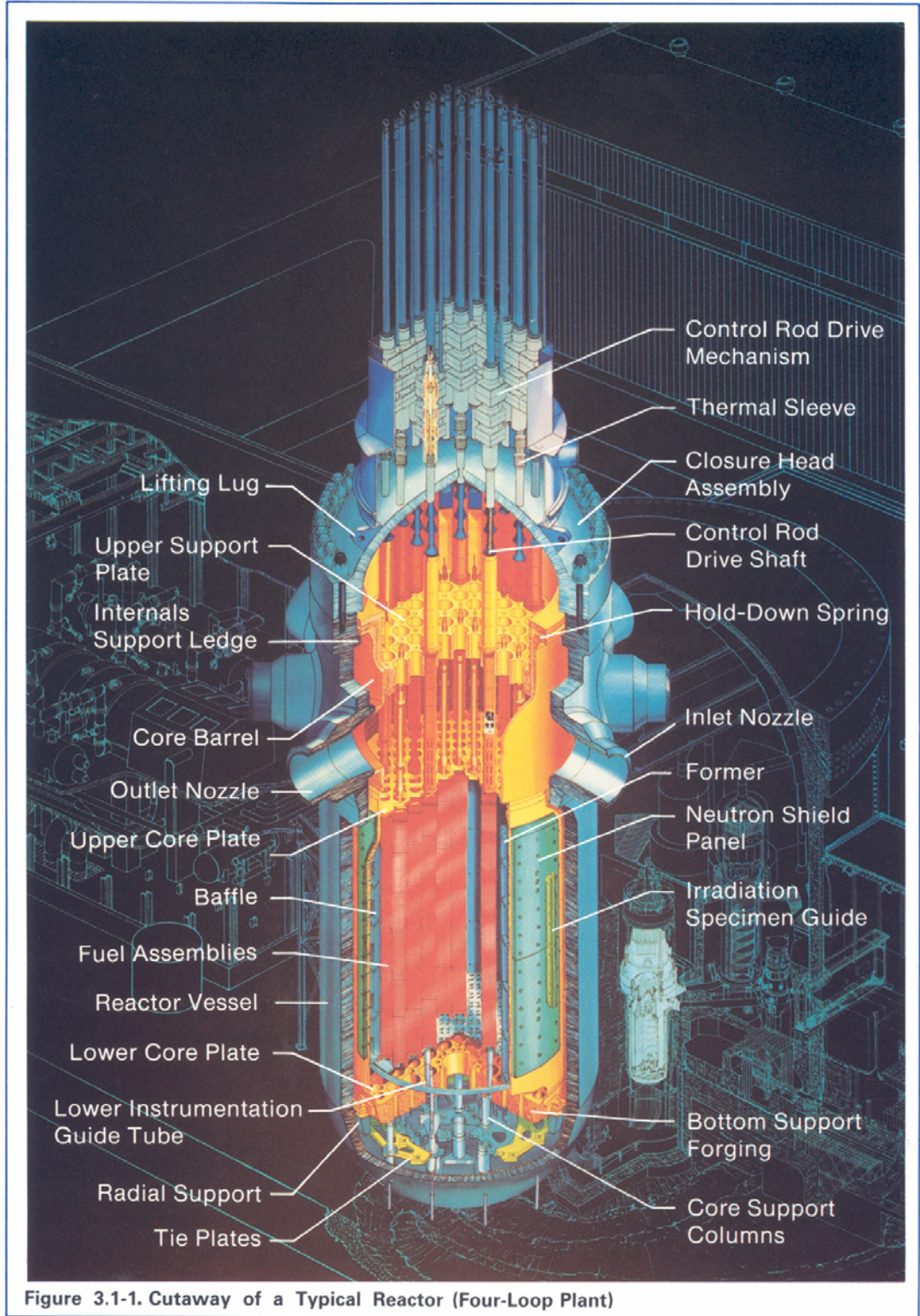

Figure 3.1-1. Cutaway of a Typical Reactor (Four-Loop Plant)

**TABLE 3.1-1  
REACTOR VESSEL PRINCIPAL PARAMETERS**

<b>Parameter</b>	<b>2-Loop-Plant</b>	<b>3-Loop Plant</b>	<b>4-Loop Plant</b>
Overall length of assembled vessel, closure head, and nozzles	39 ft, 9 in. (12.1 m)	43 ft, 4 in (13.2 m)	44 ft, 7 in. (13.6 m)
Inside diameter of shell	132 in. (3.4 m)	157 in. (4.0 m)	173 in. (4.4 m)
Radius from center of vessel to nozzle face:			
Inlet	9 ft, 7 in. (2.9 m)	10 ft, 6 in. (3.2 m)	10 ft, 11 in. (3.3 m)
Outlet	9 ft, 2 in. (2.8 m)	10 ft, 2 in. (3.1 m)	10 ft, 3 in. (3.1 m)
Nominal cladding thickness	7/32 in. (0.56 cm)	7/32 in. (0.56 cm)	7/32 in. (0.56 cm)
Minimum cladding thickness	1/8 in. (0.32 cm)	1/8 in. (0.32 cm)	1/8 in. (0.32 cm)
Coolant volume with core and internals in place	2491 ft <sup>3</sup> (71 m <sup>3</sup> )	3734 ft <sup>3</sup> (106 m <sup>3</sup> )	4885 ft <sup>3</sup> (138 m <sup>3</sup> )
Operating pressure	2332 psia (160 bar)	2332 psia (160 bar)	2332 psia (160 bar)
Design pressure	2500 psia (172 bar)	2500 psia (172 bar)	2500 psia (172 bar)
Design temperature	650°F (343°C)	650°F (343°C)	650°F (343°C)
Vessel material	Low alloy steel	Low alloy steel	Low alloy steel
Cladding material	Stainless steel	Stainless steel	Stainless steel
Number of vessel material surveillance capsules	6	6	6

The control rod drive mechanisms (CRDM) are positioned on the upper vessel head. In-core flux measuring instrumentation penetrations are located in the bottom head of the vessel.

All welds are in accordance with Section III of the ASME Boiler and Pressure Vessel Code. In general, all attachments and pressure-containing parts have full penetration welds. Partial penetration welds are used for attaching the CRDM head adapters to the head connections and instrumentation tubes to the bottom of the vessel. A seal weld is used between the head adapter and the CRDM.

## Materials

The reactor pressure vessel shell, flanges, and upper and lower heads are made of low alloy steel of Type A 533, Grades A, B, and C, Class 1, and Type A 508, Class 3, for plate and forgings, respectively. These materials are used because of their strength properties, availability in required sizes and thicknesses, satisfactory service in a neutron and gamma field, and the capability of producing high-quality weldments. The materials are also compatible with weld overlay cladding of stainless steel.

All surfaces of the reactor vessel in contact with reactor coolant are either clad with, or made from, 300 series stainless steel or Inconel.

Based on tensile and impact properties, Type A 540, Class 3, Grade B23 or B24, is selected for closure studs, nuts, and washers. Threaded surfaces and washer mating surfaces are Parkerized for rust resistance and lubricant retention. Type 304 stainless steel is used for the neutron shield panels, with the cobalt content controlled to a maximum of 0.20 percent.

All unmachined external surfaces not fabricated of corrosion-resistant materials are coated with paint that is resistant to heat, radiation, and corrosion.

## Maintenance

During the regular refueling operations, the reactor vessel head is visually inspected, including the seal faces, joint grooves, and keyways. During each head removal operation, the O-rings are replaced. A sampling of the vessel head holddown studs undergoes visual, magnetic particle, and ultrasonic tests during each refueling operation. All of the studs are subjected to these tests at least once in each 10-year period.

## Reactor Vessel Design Considering Neutron Exposure

Reactor pressure vessel design requires allowance for changes in steel properties due to fast neutron exposure of the vessel wall surrounding the core. These changes in properties include increased ultimate and yield strengths, and decreased notch ductility. The latter can be expressed as the reference nil ductility transition temperature ( $RT_{NDT}$ ) of the steel, as defined in paragraph NB-2300 of Section III of the ASME Boiler and Pressure Vessel Code, and is used in setting heatup and cooldown procedures as well as pressure-temperature limits for hydrostatic and leak tests. The shift in  $RT_{NDT}$  from an initial temperature to a higher temperature is a function of the fast neutron dose (nvt).

The  $RT_{NDT}$  shift predicted for the reactor vessel is conservative because the  $RT_{NDT}$  shift curve used is based on test data with an added margin. A recognized method of assessing the



degree of conservatism in the data and verifying the calculated neutron exposure is to perform a reactor vessel material surveillance program in the operating reactor pressure vessel.

The load restrictions on as-fabricated reactor vessels are governed by Section III of the ASME Code. The reactor vessel is designed such that the vessel wall around the core region is completely free of structural discontinuities or other stress inducers. The most significant radiation-induced material property changes are thus confined to a portion of the reactor vessel with a straight cylindrical wall in which stresses are accurately and readily analyzed.

### Vessel Material Surveillance Program

Reactor vessel surveillance programs provide information on the effect of radiation on vessel materials under operating conditions. Westinghouse surveillance programs follow ASTM E185, "Standard Recommended Practice for Surveillance Tests for Nuclear Reactor Vessels," and utilize capsules located between the neutron shield pads and the vessel wall directly opposite the center of the core. The capsules contain reactor vessel steel specimens obtained during vessel fabrication. Dosimeters, including pure nickel, copper, iron, aluminum-cobalt (0.15-percent cobalt), cadmium-shielded aluminum-cobalt, uranium-238, and neptunium-237 are placed in spacers specially drilled to contain the dosimeters. Thermal monitors are also included in the surveillance capsules.

A specimen capsule containing specimens for use in Charpy V-notch, tensile, and fracture mechanics tests can be removed from the reactor during normal refueling periods. A tentative schedule for removal of the capsules is

as follows (the actual schedule will vary from plant to plant):

Capsule	Approximate Exposure Time
1	1 to 2 years (replacement of first region)
2	5 years
3	10 years
4	20 years
5	30 years
6	Standby

### REACTOR INTERNALS

The principal core-supporting components within the reactor vessel are divided into two major structures: the upper core support structure (upper internals) and the lower internals assembly (lower core support structure). The upper core support structure (Figure 3.1-2) includes the top support plate, the upper core plate, support columns, and control rod guide tubes. Principal functions of the upper core support structure are as follows:

- To align and locate the upper ends of the fuel assemblies
- To protect withdrawn control rod clusters from lateral forces due to coolant crossflow
- To guide the control rod cluster and associated drive shaft

The principal components of the lower internals assembly (Figure 3.1-3) are the lower core support plate, core barrel, and core baffle. The

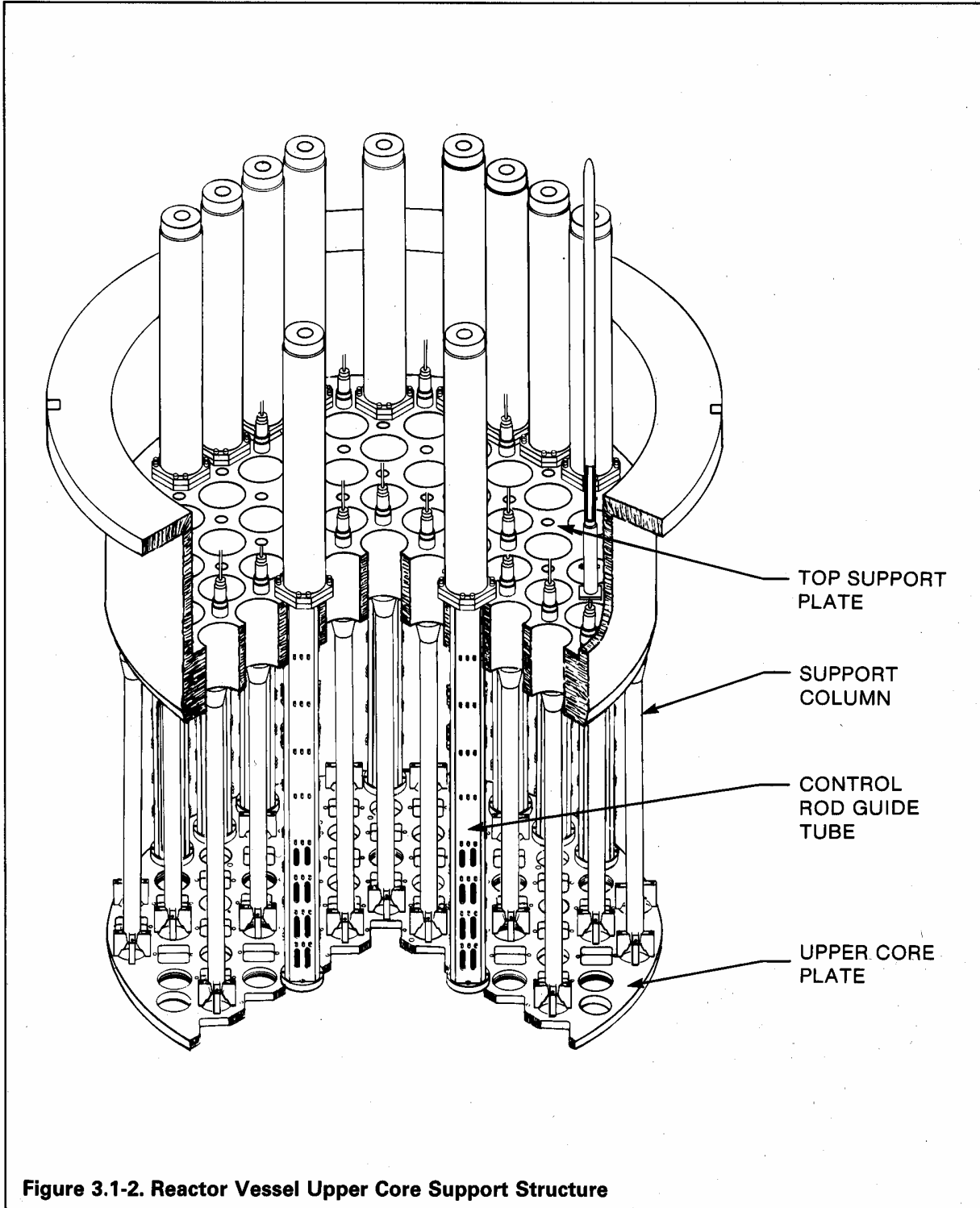

Figure 3.1-2. Reactor Vessel Upper Core Support Structure

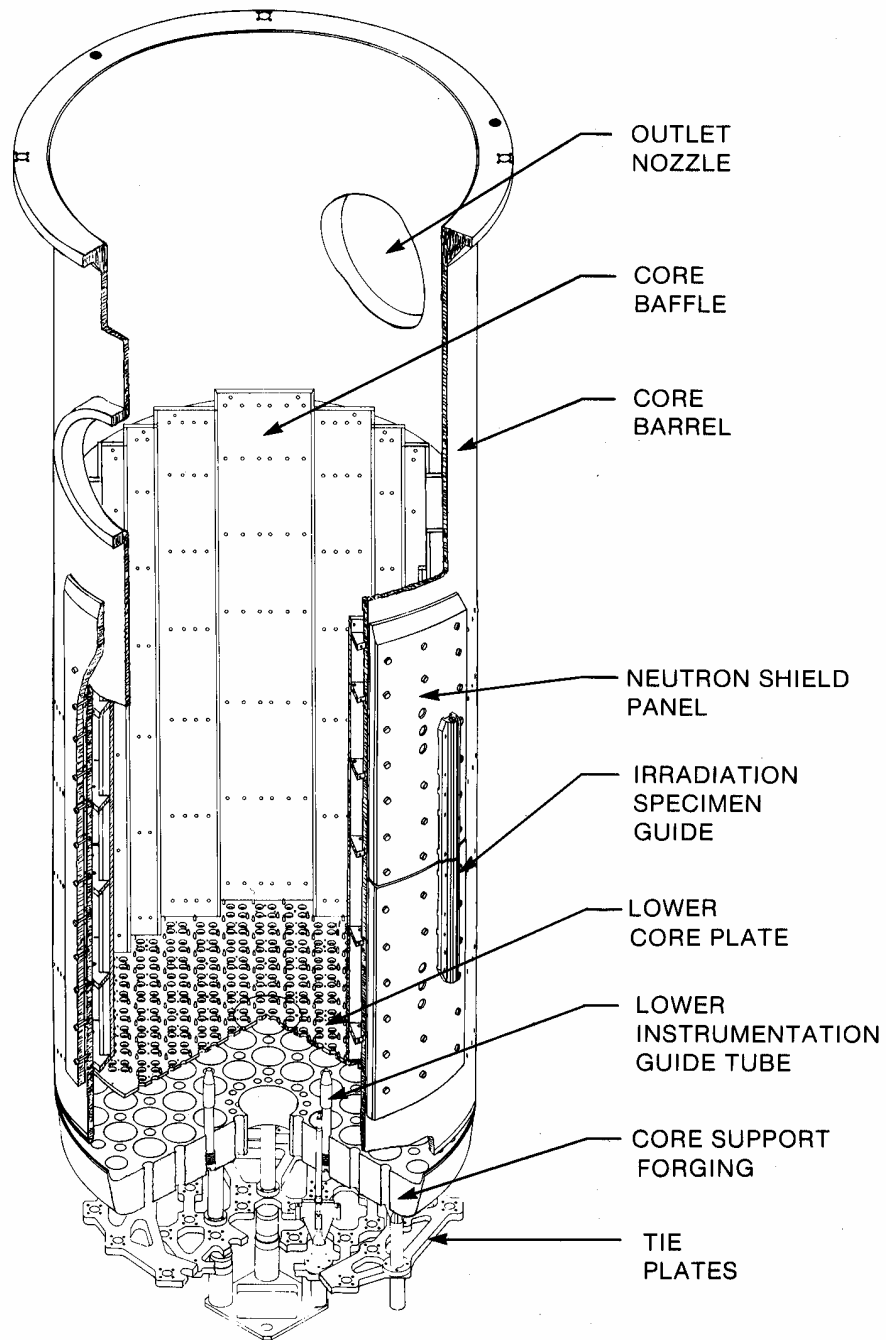

Figure 3.1-3. Reactor Vessel Lower Internals Assembly

core barrel assembly serves the following functions:

- Transfers the vertical loads, composed of the fuel assembly weight, fuel assembly preload, and control rod dynamic loading, through the core barrel to the reactor vessel flange.
- Transfers the transverse loads, caused by coolant flow and vibration, through the core barrel to the lower radial support and the reactor vessel flange.
- Aligns and positions the lower ends of the fuel assemblies
- Directs the flow of reactor coolant through the vessel and core
- Reduces the radiation dose to the reactor vessel wall
- Supports the neutron shield pads
- Guides in-core instrumentation (movable neutron detectors)

The lower core support structure (principally the core barrel) serves to provide passageways and control for the coolant flow. Inlet coolant flow from the vessel inlet nozzles proceeds down the annulus between the core barrel and the vessel wall and then into a plenum at the bottom of the vessel. The coolant then turns, flows up through the bottom support forging, and then passes through the lower core plate. Flow holes in the support plate and the lower core plate are sized to provide the desired inlet flow distribution to the core. The flow holes in the lower core plate below the peripheral fuel assemblies are machined with a smaller diameter than those in

the remainder of the core. This smaller hole size forces more flow into the center of the core where the hotter assemblies are located and accomplishes a form of inlet orificing. The peripheral assemblies are those having one or two sides defining the outer edge of the core. No attachment hardware or change in component material is necessary to this method of orificing the coolant flow into the core. After passing through the core, the coolant enters the area of the upper support structure, and then flows generally radially to the core barrel outlet nozzles and directly through the vessel outlet nozzles. A small amount of water also flows between the baffle plates and core barrel to provide additional cooling of the barrel. Similarly, a small amount of the entering flow is directed into the vessel head plenum and exits through the vessel outlet nozzles.

The thickness of the members comprising the vessel internals is governed primarily by deflection limits rather than by stress. Because stress levels are extremely low, the possibility of failure under service conditions is very low. The stress analysis of the core support structure considers static and dynamic loads (including earthquake), steady hydraulic loads, transient loads due to pump and loop pulsations, reactor coolant temperature variations, and differential expansion. A full radiation analysis on the core support structure is performed and the gamma heating rate is established. A hydraulic analysis determines the film heat transfer coefficient and temperature distribution, and thermal stresses are evaluated to verify the conservative design.

Transient changes that could occur during normal and abnormal operating conditions are fully considered in the intended service. The core support configuration is designed for safe, reliable, and rapid refueling.



Core support structure components are fabricated from Type 304 stainless steel. All welds are made to strict specifications and are checked by radiography and dye penetrant tests. Weld sequences are arranged to minimize distortion and residual stresses. Support plates are ultrasonically inspected for flaws and are dye penetrant checked for surface cracks. All major strength welds are full penetration. The

upper and lower core barrels and all major strength welds are stress-relieved at low temperatures.

The internals are designed such that they can be completely removed from the vessel. This facilitates inservice inspection of the internals and provides access for inspection of the entire inner surface of the vessel.

# chapter 3.2

## control rod drive mechanisms

The rod cluster control assemblies are positioned by latch-type magnetic jack control rod drive mechanisms mounted on the reactor vessel head. These have proven to be rugged, reliable, and eminently suitable for use in high pressure, high temperature water reactors. Principal parameters of the control rod drive mechanism (CRDM), capped latch housing assemblies, and rod position indicator assemblies are shown in Table 3.2-1.

The control rod drive mechanism (Figure 3.2-1) consists of five major subassemblies: pressure vessel, internal latch assembly, drive rod, operating coil stack, and seismic sleeve assembly.

All moving components of the CRDM are contained in a stainless steel pressure vessel assembly attached to a head adapter housing. The adapter is welded to the reactor vessel head and constitutes, in effect, an integral part of the vessel. The pressure vessel assembly, including the head adapter housing, is completely free of mechanical seals and of penetrations for hydraulic and electric lines. It is designed for full system pressure of 2500 psia (172.3 bar a).

**TABLE 3.2-1**  
**PRINCIPAL PARAMETERS OF CONTROL ROD DRIVE MECHANISMS**

Quantity	53
Maximum control rod speed	45 in./min. (1.9 cm/sec)
Stepping distance	5/8 in. (1.6 cm)
Pressure housing material	Stainless steel
Pressure housing design pressure	2500 psia (172.3 bar a)
Pressure housing design temperature	650°F (343.3°C)
Overall mechanism length	233.7 in. (594 cm)
<b>Capped Latch Housing Assembly</b>	
Quantity	8
Pressure housing material	Stainless steel
Pressure housing design pressure	2500 psia (172.3 bar a)
Pressure housing design temperature	650°F (343.3°C)
Overall housing length	56.4 in. (143 cm)
<b>Rod Position Indicator Assembly</b>	
Quantity	53
Overall RPI assembly length	158 in. (401 cm)

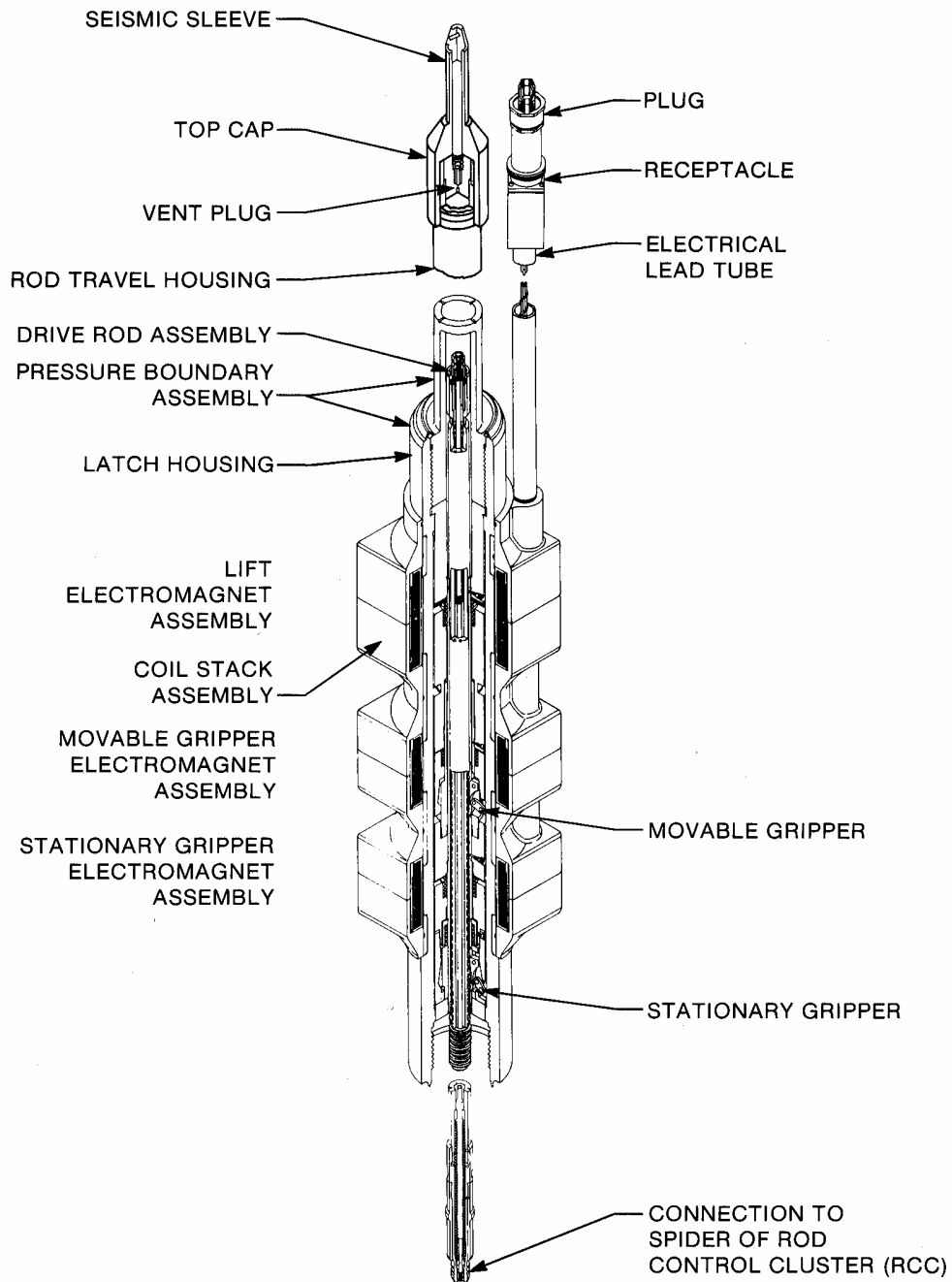

**Figure 3.2-1. Cutaway of a Typical Control Rod Drive Mechanism**

The operating coil stack assembly consists of three independent coils installed over the outside of the latch housing. Because the coil stack assembly rests on a shoulder on the latch housing without any mechanical attachment, it can, if desired, be removed and replaced while the reactor is pressurized. An electrical receptacle assembly is provided on the coil stack assembly for connection of external wiring through the plug assembly provided. An air-cooling system is utilized to cool the operating coil stack assembly.

The internal latch assembly of the CRDM, consisting of gripper latches, poles, and plungers is located inside the latch housing. The gripper latches, which engage the grooved region of the drive rod assembly, will lift, lower, or hold the drive rod assembly with the attached rod cluster control assembly (RCCA) and are operated by poles and lock plungers encircling the drive rod assembly. These poles and lock plungers are activated by external operating coils which are energized in the proper sequence, and for the proper length of time, by the solid-state control system. The inward and outward motion of the latch arms always occurs under the condition of no mechanical load, which minimizes wear of latch tips and drive rod assembly grooves. Reactor coolant water provides the necessary lubrication.

Circumferential grooves in the drive rod assembly are engaged by the gripper latches of the latch

assembly. A coupling attached to the lower end of the drive rod assembly connects to a RCCA. Means are provided for remotely engaging or disengaging this coupling from the RCCA.

The seismic sleeve assembly fits over the top of the CRDM rod travel housing and locates in a hole in the missile shield plate to prevent excessive lateral movement during a seismic event.

During normal plant operation, the CRDMs serves to hold in position the RCCAs that have been withdrawn from the core. Under this holding mode of operation, only one coil is energized to engage its respective gripper latches with the drive rod assembly. If power to this coil is cut off, either deliberately in reactor trip or because of an accidental power failure, the RCCA falls by gravity into the core.

The capped latch housing assembly, provides for installation of a CRDM after plant startup when additional RCCAs are required (i.e., for alternative fuel cycle capability).

A rod position indicator coil stack, consisting of small cylindrical coils mounted on a stainless steel tube, fits over the rod travel housing of the mechanism. The secondary side output of these coils is a function of the position of the drive rod assembly in the coil stack; this makes it possible to obtain incremental indication of control rod position.

# chapter 3.3

## reactor coolant pumps

Each reactor coolant loop contains a vertical, single-stage, shaft-seal pump designed to pump large volumes of reactor coolant at high pressures and high temperatures. A typical pump is shown in Figure 3.3-1 with principal design parameters listed in Table 3.3-1. The complete unit is a vertical assembly consisting of (from top to bottom) a motor, motor support stand, seal assembly and hydraulic unit.

### HYDRAULIC UNIT

Reactor coolant is pumped by an impeller attached to the bottom of the rotor shaft. The coolant is drawn up through the bottom of the casing, up through the impeller, and discharged through the diffuser and an exit nozzle in the side of the casing. A diffuser and turning vane assembly converts velocity head from the impeller to pressure head, and directs the flow to the single discharge nozzle in the circular casing. A thermal barrier incorporated as an integral part of the diffuser and turning vane assembly limits the heat transfer from the casing into the seal and bearing regions.

The motor and pump assemblies can be removed from the casing for maintenance or inspection without removing the casing from the piping. All parts of the pump in contact with the reactor coolant are of stainless steel except for the bearings and certain special components.

### HEAT EXCHANGER

A coil-type heat exchanger of stainless steel tubing is located inside the diffuser and turning vane assembly and below the water-lubricated radial bearing. Low-pressure cooling water is circulated inside the heat exchanger tubing. During normal operation, the load on the heat exchanger is minimal because cool injection water from the Chemical and Volume Control System is flowing over the coils at a slow rate. The heat exchanger protects the water-lubricated bearing and the seal system in the event of injection water failure by cooling the 550°F (288°C) reactor coolant water which will

**TABLE 3.3-1  
REACTOR COOLANT PUMP TYPICAL  
DESIGN PARAMETERS**

Number and type	One vertical, single-stage, shaft-seal circulating water pump per loop
Design capacity	97,600 gpm (6.15 m <sup>3</sup> /sec)
Design head	280 ft (85.3 m)
Design pressure	2500 psia (172° bar)
Design temperature	650°F (343°C)
Suction temperature at full power	557°F (292°C)
Motor type	ac induction
Motor voltage	6,600 volts
Casing diameter	6 ft, 5 in. (196 cm)
Overall height	28 ft (8.5 m)
Operating speed	1189 rpm
Ambient temperature	120°F (49°C)



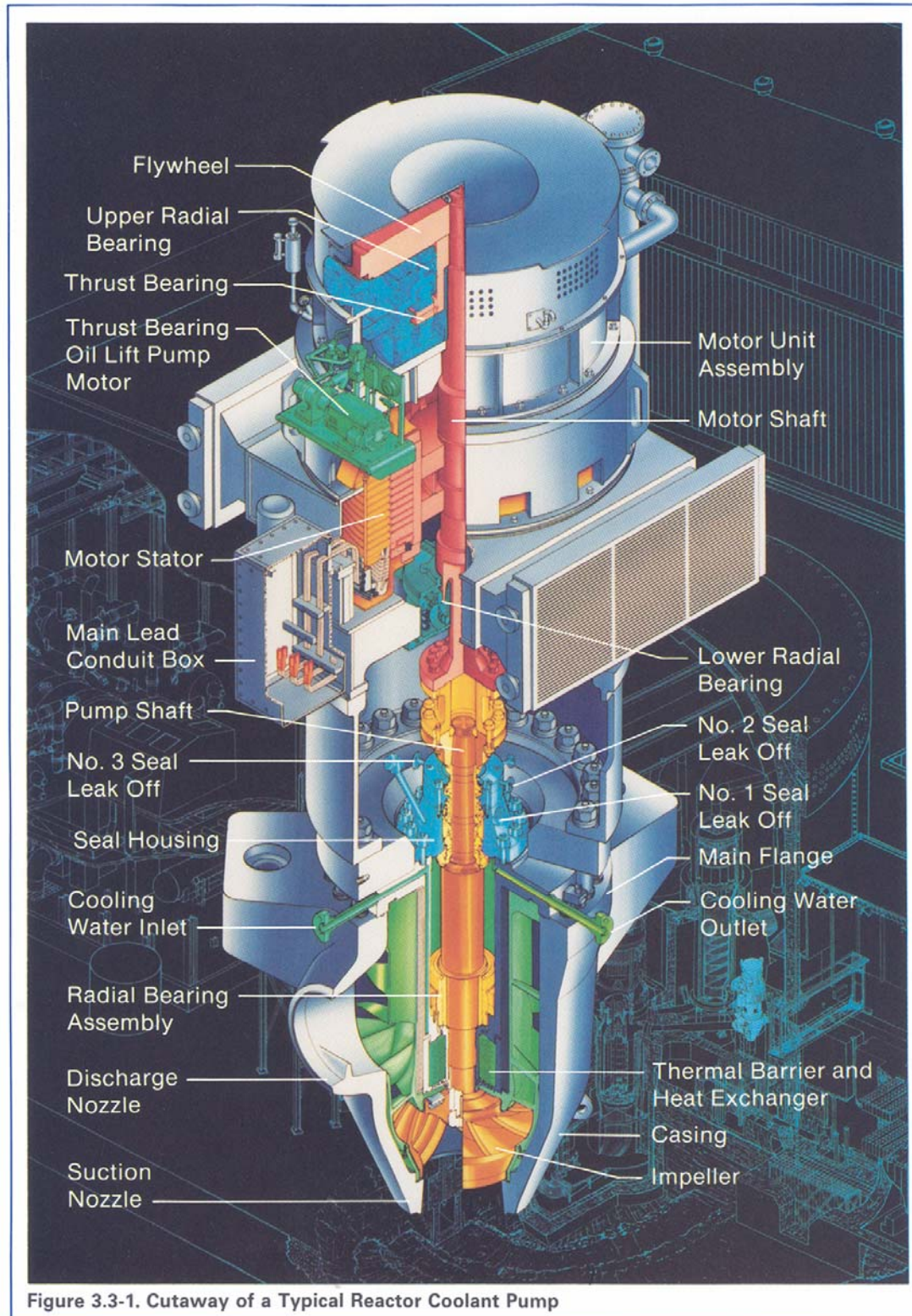

Figure 3.3-1. Cutaway of a Typical Reactor Coolant Pump

flow outward toward the seals under this condition of failure. The heat exchanger designed so that it can be removed for inspection if desired. Maintenance is not normally required.

## LOWER BEARING

The complete pump and motor assembly contains three radial bearings. Two of these are located in the motor and are described later. The third (lower) bearing is located in the pump unit above the heat exchanger and below the seal assembly. This carbon-graphite, water lubricated bearing operates against a Stellite-clad stainless steel journal. The bearing is mounted in a spherical seat so as to be angularly self-aligning with the shaft.

## INJECTION WATER

Access for high-pressure injection water is provided through the heat exchanger support cylinder flange. This water acts to cool both the lower and upper parts of the pump and seal assembly as well as to provide clean water for lubrication of the lower radial bearing and the seal system. Under normal operating conditions, water is injected at a rate of 8 gallons per minute (0.5 l/sec). Of this flow, 5 gallons per minute (0.3 l/sec) pass downward through the heat exchanger assembly and along the shaft into the casing, removing heat conducted by the shaft and parts of the thermal barrier. The remaining 3 gallons per minute (0.2 l/sec) of injection water pass through the seal assembly.

## SHAFT SEAL SYSTEM

The shaft seal system (Figure 3.3-2) consists of three seals operating in a series arrangement and described below.

**No. 1 Seal** – The primary seal (No. 1 seal) is located above the lower radial bearing and constitutes the most important element in the seal system. It is basically a film-riding face seal. The film is produced by the system pressure drop across the seal and therefore does not require shaft rotation for its existence. Normal leakage rate for this seal is 3-gallons-per-minute (0.2 l/sec) at system operating pressure. Leakage flow is radially inward toward the shaft, and the design is such that the axial pressure forces are balanced. Because the seal ring rides on a thin film, it does not come in contact with the seal runner.

**No. 2 Seal** – This seal normally accepts a portion of the 3-gallons-per-minute (0.2 l/sec) leakage from the No. 1 seal at a pressure of approximately 50 psi (3.4 bar) and seals it against a backpressure of several feet of water. Normal leakage rate for the No. 2 seal is 3 gallons per hour (3.2 cm<sup>3</sup>/sec). The pressure balanced rubbing face-type seal is of conventional design and employs a rotating runner and a stationary carbon member. Although the seal normally handles only 50 psi (3.4 bar) on the high-pressure side, it is designed such that in an emergency it can operate with the full system pressure across its face in either the rotating or stationary state. Although its life under these latter emergency conditions will be reduced, it will permit limited pump operation or an orderly shutdown without gross leakage.

**No. 3 Seal** – The double dam No. 3 seal is also a mechanical-rubbing face-type seal designed such that clean contaminant-free water can be injected into the center of the sealing surface. This No. 3 seal injection water flows through the seal in both directions to maintain a clean

PRELIMINARY OPERATING PARAMETERS		
SEAL	INLET PRESSURE	FLOW RATE
NO. 1	2250 PSI (155 BAR)	3 GPM (0.2 L/SEC)
NO. 2	50 PSI (3.4 BAR)	3 GPH (3 CM <sup>3</sup> /SEC)
NO. 3	6 PSI (0.4 BAR)	200 CM <sup>3</sup> /HR
NO. 3 INJECTION	10 PSI (0.7 BAR)	400 CM <sup>3</sup> /HR

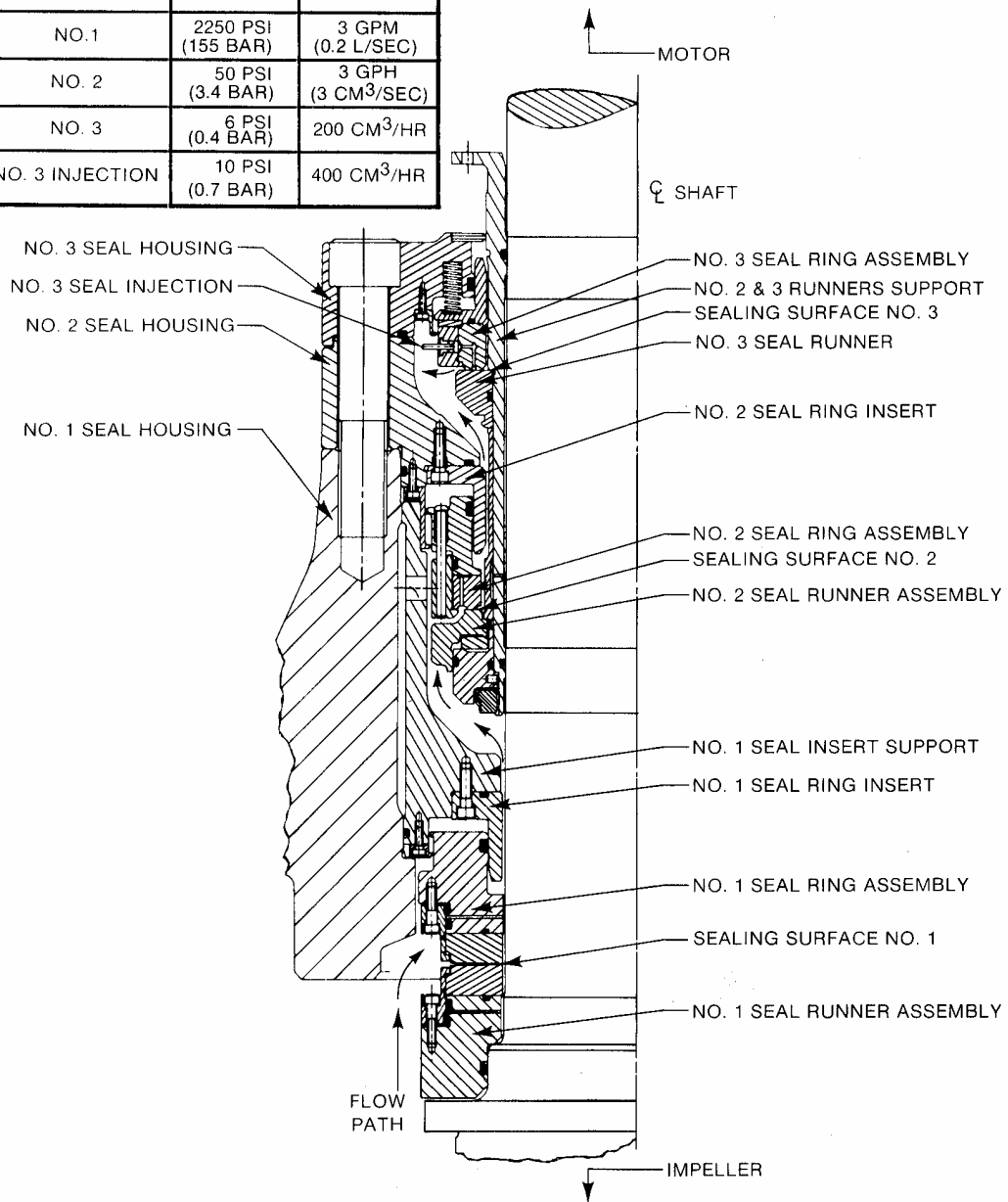

Figure 3.3-2. RCP Typical Shaft Seal Arrangement



lubricated surface on the seal faces and to prevent primary system water from passing the No. 3 seal. The low-pressure clean water injection between the seal surfaces minimizes deposition of abrasive boric acid crystals between the seal faces, cools the seals, and virtually eliminates the leakage of contaminated water and gas to the containment. The clean injection water flow rate is 800 cm<sup>3</sup> per hour. The only leakage from the reactor coolant pumps is a small amount of this clean water through the vapor guard at the top of the shaft seal housing.

**Cartridge-Type Seal Assembly** – The No. 2 and No. 3 seals are mounted in a single cartridge-type seal assembly. The cartridge seal design eliminates individual replacement of the No. 2 and No. 3 seals on the pump. Factory assembled and tested, the No. 2 and No. 3 cartridge seal package is installed in the pump as a unit to avoid individual handling of the seals and reduce the chance for damage or error in installation. The cartridge capability allows inspection of the No. 2 and No. 3 seals under more ideal conditions away from the pump, either inside or outside containment. During replacement of the No. 2 and No. 3 seals, the No. 1 seal can be removed for inspection without removing the No. 1 seal housing and connecting piping.

The cartridge seal allows the No. 2 seal to remain closed during backseating of the pump shaft which eliminates the need to drain down the system when uncoupling and lowering the pump shaft.

### **SHAFT SPOOL PIECE**

A removable spool piece in the reactor coolant pump shaft is included to facilitate inspection

and maintenance of the pump shaft seal system. Incorporation of the spool piece in the pump shaft reduces personnel radiation exposure and pump maintenance downtime by minimizing the number of operations involved in pump shaft seal inspection and maintenance. The removable spool piece also allows shaft seal access without removing the pump motor. This feature eliminates the need for breaking fluid, electrical, and instrumentation connections during motor removal, and for subsequent pump and motor alignment when the motor is reinstalled. The shaft spool piece is designed for easy removal and replacement.

### **MOTOR**

The motor is a vertical, solid-shaft, single-speed, air-cooled, three-phase, squirrel-cage induction motor with a thermalastic-epoxy insulation system. The rotor and stator are of conventional design.

A radial guide bearing is located below the motor rotor. This bearing operates in an oil sump which has an integral heat exchanger through which low-pressure cooling water circulates. The bearing is a babbitt-on-steel, pivoted-pad guide bearing positioned by jack screws and held in place with lockplates.

A double-acting Kingsbury-type thrust bearing (accommodating either upward or downward thrust) is located above the rotor. The bearing consists of pivoted segmental shoes that tilt and allow the oil to assume a thin wedge-shaped film between the shaft-mounted runner and the stationary pivoted shoes. An oil lift system provides the initial oil film during startup. High-pressure oil is pumped into the center of the shoes, slightly lifting the rotor assembly. Because shoe tilt can vary with motor shaft

speed, the bearing is self-adjusting during all modes of operation. The oil also circulates through the upper radial guide bearing and through a separate heat exchanger where it is cooled. The upper radial guide bearing is similar in design to the lower bearing. Space heaters in the motor keep the windings warm and dry when the unit is idle or in storage.

An antireverse device is installed integral with the motor. It requires no lubrication and has no moving parts to wear during normal operations. The device prevents reverse rotation of an idle pump due to backflow generated by other operating reactor coolant loops. The antireverse mechanism consists of pawls mounted on the outside diameter of the flywheel, a serrated ratchet plate mounted on the motor frame above the oil pot, a spring return for the ratchet plate, and two shock absorbers. After the motor ceases rotation, at least one pawl will engage the ratchet plate. As the motor starts to rotate in the opposite direction, the ratchet plate will also rotate until stopped by the springs and shock absorbers. The rotor will then remain stopped until the motor is energized again, at which time the pawls will drag over the ratchet plate until the motor reaches a speed of about 75 rpm. At this speed, centrifugal force is sufficient to hold the pawls in an elevated position. Above this speed there is no rubbing contact between parts, and the pawls are motionless relative to their housing.

A flywheel in the motor increases the total rotating inertia, allowing the pump to coastdown slowly after deenergizing. This provision, together with the Reactor Control and Protection System, maintains adequate flow through the reactor core in the event of a loss of power to the pumps. The flywheel material is subjected to a 100-percent volumetric ultrasonic inspection

and to a magnetic particle or liquid penetrant examination in accordance with ASME Boiler and Pressure Vessel Code, Section III.

## **GROUNDING PAD**

Terminals are provided on the motor and pump unit for connection to the station ground.

## **ASSEMBLY**

The entire motor and seal assembly is bolted to the pump flange to provide proper alignment. The procedure of assembling the motor to the pump consists of lowering the pump shaft to the backseat provided on the housing of the thermal barrier heat exchanger, centering the pump shaft radially at the top of the seal area by means of a centering device, shimming the motor base as necessary to parallel the two coupling faces, measuring runout between the two coupling faces by turning the motor rotor, adjusting runout to within tolerance by use of motor jacking screws, removing the centering device, and finally raising the pump shaft by installing and tightening the coupling bolts.

## **PUMP SUPPORT**

The pump is provided with three large support feet located radially on the pump casing.

## **VIBRATION MONITORING EQUIPMENT**

Each reactor coolant pump is provided with a vibration monitoring system that continuously monitors vibrations of the pump shaft and frame. The system consists of three proximity probes, two seismoprobes, equipment housing and mounting brackets, and two meters per pump. A common power supply, equipment rack, and

keyphasor module are provided for each plant. The keyphasor module allows for convenient pump balancing through use of an oscilloscope should it be necessary. Alarm lights on the meters provide warning and danger signals. Audible alarm capability is also provided.

The primary benefits to be gained from using a continuous vibration monitoring system include pump balancing and the capability to identify increasing vibration levels that could indicate potential problems within the system. Early identification of problems enables investigation and, if required, orderly shutdown which can prevent serious damage.

### **LOCKED ROTOR PROTECTION SYSTEM**

The locked rotor protection system protects against abnormal motor starting conditions. Following initial energizing of the pump motor, if the rotor fails to rotate, a trip signal is given. At the time when half speed should be reached, a second check is made. If the rotor is not at

approximately half speed at the proper time, a trip signal is given. Following a successful start and after 30 seconds, the locked rotor circuit is bypassed. The signal to the protection system is generated by the keyphasor probe in the vibration monitoring system which reads a notch on the pump coupling.

### **OIL SPILLAGE PROTECTION AND CONTROL SYSTEM**

The reactor coolant pump motor is equipped with a catch basin and enclosures at strategic locations to minimize the possibility of leaking motor oil making contact with hot RCS components and piping thereby reducing the potential for oil fires. An oil enclosure surrounds the thrust bearing oil lift pump to isolate the high-pressure oil components from the environment. A suitable drain connection is provided to remove oil in the event of leakage. Drip pans are located below the upper and lower motor oil pots to collect oil that may leak from the pot. A drain connector is provided to allow field piping to direct excess oil to a collection point.

# chapter 3.4

## steam generators

Pressurized water reactors utilize a closed-cycle system design principle. This means that radioactive coolant in the reactor cycle is completely separated from the turbine-generator cycle. The high-temperature coolant water from the reactor, however, must create steam for the turbine-generator. The link connecting the two cycles is the steam generator.

Each loop of the Reactor Coolant System (RCS) contains a vertically mounted U-tube steam generator (Figure 3.4-1). These steam generators consist of two integral sections: an evaporator section and a steam drum section. The evaporator section consists of a U-tube heat exchanger while the steam drum section houses moisture-separating equipment. The steam drum section is located in the upper part of the steam generator. Principal design data are listed in Table 3.4-1. The steam generators are designed and manufactured in accordance with Sections II, III, and IX of the ASME Boiler and Pressure Vessel Code.

Westinghouse introduced the vertical U-tube steam generator having an integral steam drum for the world's first commercial PWR nuclear power station (Yankee-Rowe) which started operation in 1960. Several models of this type of steam generator have been produced with variations in size, materials of construction, and design features. The design changes have been evolutionary, building on the operating experience of previous designs. The Model F

steam generator, which is described below, has been the standard model since 1976.

High-pressure, high-temperature reactor coolant flows into the steam generator channel head, through the Inconel U-tubes, and back to the channel head. A partition plate divides the channel head into inlet and outlet sections. An access opening for inspection and maintenance is provided in each section of the channel head. To prevent leakage across the tube joints, the U-tubes are welded to the tube sheet. The tubes are supported at intervals by horizontal tube support plates.

Feedwater enters the unit through a nozzle located on the upper shell and is distributed by a feedwater ring into the downcomer annulus formed by the tube bundle wrapper and steam generator shell. The feedwater mixes with recirculation flow and enters the tube bundle near the tubesheet. Boiling occurs as the fluid rises in the tube bundle.

A set of centrifugal moisture separators, located above the tube bundle, removes most of the entrained water from the steam. Perforated plates are included at the entrance to the second stage of separation. Steam dryers are employed to increase the steam quality to a minimum of 99.75 percent (0.25-percent moisture). An integral steam flow restrictor is provided in the steam nozzle to limit the quantity of steam flow in the event of a steamline break.

The steam drum has bolted and gasketed access openings for inspection and maintenance of the steam generator upper internals.

All pressure-containing parts, with the exception of the Inconel tubes, are made of carbon or low



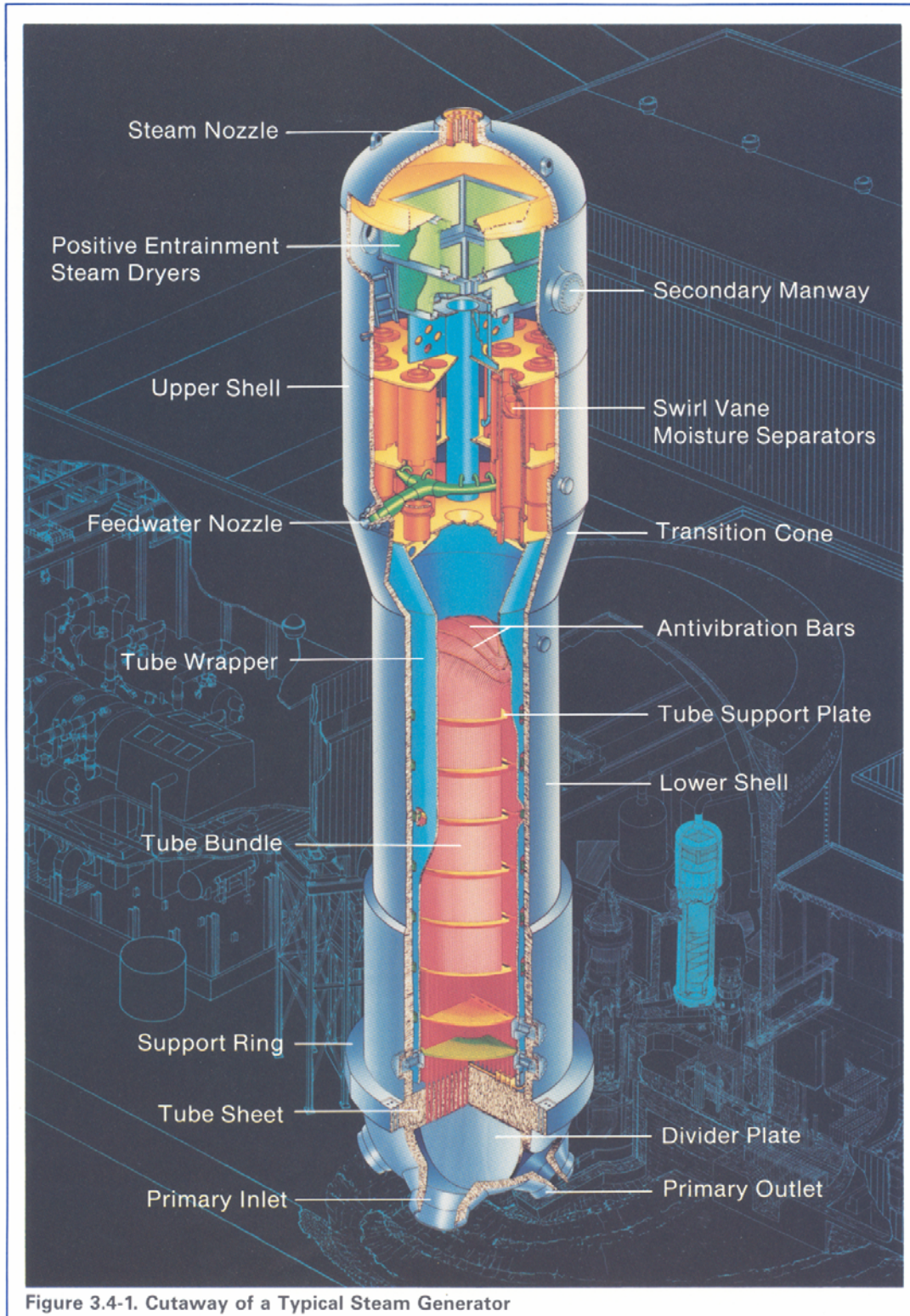

alloy steel. All surfaces in contact with the reactor coolant are clad with stainless steel or Inconel.

The Model F steam generator incorporates a quatrefoil tube support plate design. The quatrefoil design directs the steam water flow in the open areas adjacent to the tube. The tube support plate material is Type 405 stainless

steel. In the U-bend, tube support is provided by three sets of chrome-plated Inconel anti-vibration bars.

The steam generator has incorporated into its design a number of improvements developed through the experience gained at Westinghouse operating plants. The feedwater distribution ring preferentially distributes flow to the hot-leg

**TABLE 3.4-1  
STEAM GENERATOR PRINCIPAL DESIGN DATA**

Number and type	1 vertical, U-tube steam generator with integral steam-drum per loop
Height overall	67 ft, 8 in. (20.6 m)
Upper shell OD	14 ft, 7-3/4 in. (4.5 m)
Lower shell OD	11 ft, 3 in. (3/4m)
Operating pressure, tube side	2250 psia (155 bar)
Design pressure, tube side	2500 psia (172 bar)
Design temperature, tube side	650°F (343°C)
Full load pressure, shell side	
2-Loop Plant	920 psia (63 bar)
3-Loop Plant	964 psia (66 bar)
4-Loop Plant	1000 psia (69 bar)
Steam flow per steam generator	3,813,000 lb/hr (480 kg/sec)
Maximum moisture at outlet (full load)	0.25 %
Design pressure, shell side	1200 psia (82.7 bar)
Reactor coolant flow rate	35,075,000 lb/hr (4419 kg/sec)
Reactor coolant inlet temperature	621°F (327°C)
Reactor coolant outlet temperature	558°F (292°C)
Shell material	Mn-Mo steel
Channel head material	Carbon steel clad internally with stainless steel
Tube sheet material	Ni-Mo-Cr-V clad with Inconel on primary face
Tube material	Thermally treated Inconel
Steam generator weights	
Dry weight, in place	346 tons (314,000 kg)
Normal operating weight, in place	422 tons (384,000 kg)
Flooded weight (cold)	560 tons (508,000 kg)

portion of the tube bundle. The tube lane has been blocked at the periphery so that all the recirculation flow is forced to pass through the tube bundle. The blowdown pipe has been ported to draw flow preferentially from potential sludge accumulation regions. The potential for waterhammer in the feedwater system has been greatly diminished by the incorporation of J-tubes on the feedwater distribution ring and a sealed thermal sleeve on the feed nozzle inlet.

Secondary-side access for inspection or maintenance has been provided by including six access openings located in the shell near the top of the tubesheet. A wet layup connection is provided to maintain water chemistry during

shutdown periods by recirculating water through the steam generator.

The metallurgical structure of the Inconel 600 tube material has been optimized through a thermal treatment of the tubes at the tube mill. The thermal treatment is accomplished while the tubes are in the straight length configuration. Thermal treatment has the additional advantage of reducing residual stresses. After bending, the narrow-radius U-bend tubes are reinserted into the thermal treatment furnace to relieve stresses introduced during bending. In addition, a hydraulic tube expansion process is utilized during steam generator assembly as a final means of minimizing residual stresses that are present at the tube-to-tube-sheet interface.

# chapter 3.5

## pressurizer

The pressurizer (Figure 3.5-1) maintains the Reactor Coolant System (RCS) pressure during steady-state operation and limits pressure changes during transients. Replaceable immersion heaters and a spray nozzle are located in the pressurizer. Safety and relief valves discharge to a pressurizer relief tank. Principal design data for the pressurizer are listed in Table 3.5-1.

During steady-state operating conditions, approximately 60 percent of the pressurizer volume is occupied by water and 40 percent by steam. Electric immersion heaters, located in the lower section of the vessel, keep the water at saturation temperature and maintain a constant system operating pressure.

A reduction in plant electrical load causes a temporary increase in average reactor coolant temperature with an attendant increase in coolant volume. The expansion of the reactor coolant raises the water level in the pressurizer. This increase in water level compresses the steam, raising the pressure and actuating valves in the spray lines. Reactor coolant from the cold leg of a coolant loop sprays into the steam space and condenses a portion of the steam. This quenching action reduces pressure and limits the pressure increases.

An increase in plant electrical load results in a temporary decrease in average coolant temperature and a contraction of coolant volume. Coolant then flows from the pressurizer into the loops, thus reducing the pressurizer

level and pressure. Water in the pressurizer flashes to steam to limit the pressure reduction. This reduction in pressure also energizes the immersion heaters, heating the remaining water in the pressurizer to further limit the pressure reduction.

Reductions in plant electrical load with resultant pressure increases beyond the pressure-limiting capability of the pressurizer spray system cause the air-operated relief valves to open. These valves are automatically opened at a pressure below system design pressure. They can also be opened manually from a control console in the control room. If system pressure continues to rise, self-actuating ASME-code safety valves will open. Steam from the safety and/or relief valves is piped to the pressurizer relief tank which contains sufficient water to condense the steam. Cold water can be sprayed into the pressurizer relief tank to increase the heat sink capacity. A rupture disc vents the tank to the containment if design pressure is exceeded.

### **PRESSURIZER LEVEL CONTROL SYSTEM**

Under steady-state operation, pressurizer level represents a balance of injection water flow into the RCS and water letdown flow into the Chemical and Volume Control System. Therefore, when water level begins to change, an imbalance exists of in and out water flow conditions. This imbalance represents a change in water inventory in the RCS.

Transient load conditions will also produce a change in pressurizer water level. This is brought about by the fact that in the pressurized system, water volume changes as a function of reactor coolant average temperature. When gradually coming down in load, the decrease in



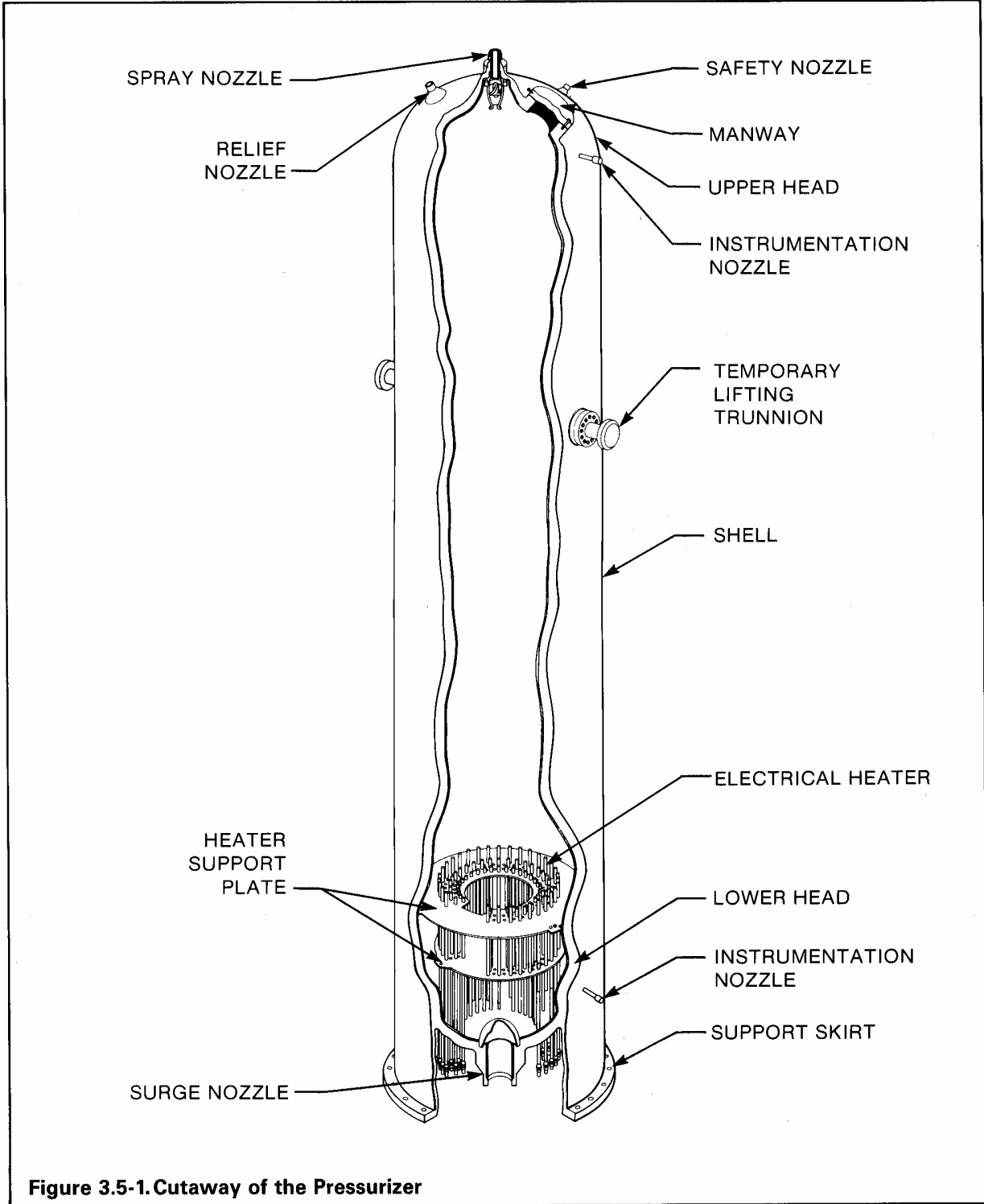

**TABLE 3.5-1  
PRESSURIZER PRINCIPAL DESIGN DATA**

	<b>2-Loop Plant</b>	<b>3-Loop Plant</b>	<b>4-Loop Plant</b>
Number and type	1 two-phase water and steam pressurizer	1 two-phase water and steam pressurizer	1 two-phase water and steam pressurizer
Overall height	31 ft, 5 in. (9.6 m)	42 ft, 1 in. (12.8 m)	52 ft, 9 in. (16.1 m)
Overall diameter	7 ft, 7-1/2 in. (2.3 m)	7 ft, 7-1/2 in. (2.3 m)	7 ft, 8 in. (2.3 m)
Water volume	600 ft <sup>3</sup> (17.0 m <sup>3</sup> )	840 ft <sup>3</sup> (23.8 m <sup>3</sup> )	1080 ft <sup>3</sup> (30.6 m <sup>3</sup> )
Steam volume	400 ft <sup>3</sup> (11.3 m <sup>3</sup> )	560 ft <sup>3</sup> (15.9 m <sup>3</sup> )	720 ft <sup>3</sup> (20.4 m <sup>3</sup> )
Design pressure	2500 psia (172 bar)	2500 psia (172 bar)	2500 psia (172 bar)
Design temperature	680°F (360°C)	680°F (360°C)	680°F (360°C)
Type of heaters	Electric immersion	Electric immersion	Electric immersion
Number of heaters	78	78	78
Installed heater power	-1000 kw	1400 kw	1800 kw
Number of relief valves	2 power-operated	2 power-operated	2 power-operated
Number of safety valves	3 self-actuating	3 self-actuating	3 self-actuating
Spray rate			
Pressure transient	500 gpm (32 l/sec)	700 gpm (44 l/sec)	900 gpm (57 l/sec)
Continuous	1 gpm (63 ml/sec)	1 gpm (63 ml/sec)	1 gpm (63 ml/sec)
Shell material	Mn-Mo steel, clad internally with stainless steel	Mn-Mo steel, clad internally with stainless steel	Mn-Mo steel, clad internally with stainless steel
Dry weight	116,000 lb (52,600 kg)	155,300 lb (70,400 kg)	195,500 lb (88,700 kg)
Normal operating weight	138,200 lb (62,700 kg)	186,400 lb (84,500 kg)	234,000 lb (106,000 kg)
Flooded weight (70°F) (21°C)	178,400 lb (80,900 kg)	242,600 lb (110,000 kg)	307,800 lb (140,000 kg)

reactor coolant average temperature causes the total water volume to contract, which lowers the pressurizer level. On a gradual load pick-up, the increase in reactor coolant average temperature causes the total water volume to expand. Hence, the expansion of water volume raises the pressurizer level. A change in water volume is not a change in water inventory. However, the level does change with temperature. By programming the pressurizer level setpoint as a function of reactor coolant average temperature almost no level control system action will be required because of external load changes. Under steady-state conditions, the level controller will only take control action to maintain the level at the programmed setpoint. This will serve to correct for changes in water inventory in the RCS. Then, when the level does deviate from the setpoint, the level control system will re-establish the in and out water flow conditions and maintain the required water inventory by restoring the level back to the setpoint.

The pressurizer level control system regulates the positive displacement pump speed and/or the centrifugal charging pump flow to drive the pressurizer level to its setpoint value.

## **PRESSURIZER PRESSURE CONTROL SYSTEM**

The pressurizer pressure control system limits pressure excursions which might induce reactor trip, changes in reactivity, and actuation of the relief valves. The pressurizer pressure is maintained at a fixed setpoint.

The pressurizer pressure controller is provided with proportional, rate, and reset adjustments. Deviation of pressurizer pressure from its setpoint is the signal used as an input to the pressurizer pressure controller. The output of the pressurizer pressure controller drives the proportional spray controllers and actuates the backup heaters and the power relief valves at their fixed operating points.

The control system will perform as follows. Some of the heaters are energized to provide heat input to compensate for pressurizer heat losses and achieve equilibrium between water and steam. For small pressurizer pressure variations, the proportional heaters will increase or decrease heat to restore system pressure back to the setpoint. For large pressurizer pressure variations caused by large insurges, steam is compressed and the pressure is raised above the setpoint. The heaters would be turned off and the spray applied. The relatively cool spray water condenses the steam. This action rapidly dissipates the energy from the pressurizer, and system pressure is restored back to the setpoint. On a large pressure decrease, the proportional heaters are set to their maximum power level and the backup heaters are energized to add a large block of heat to change the water into steam until the pressure setpoint is re-established.

The pressurizer pressure control system is placed on automatic control when the RCS is at its normal operating pressure after plant startup.

# chapter 3.6

## pipng and valves

### PIPING AND INSULATION

Reactor coolant piping and fittings are made of stainless steel or are carbon steel clad with stainless steel. Carbon steel is used for the pressurizer relief line which connects the pressurizer safety and relief valves to the flanged nozzle on the pressurizer relief tank, and for the nitrogen supply, vent, and drain lines for the pressurizer relief tank. The pressurizer surge and spray lines, loop drains, and connections to other systems are of austenitic stainless steel. Except for the flanged pressurizer safety valve outlet nozzles, all joints and connections are welded. Thermal sleeves are installed where high thermal stresses could develop because of rapid changes in fluid temperature during transients.

Valves, piping, and equipment which operate at elevated temperatures are normally covered with thermal insulation to reduce heat losses.

Insulation covering the piping and components of the reactor coolant system are designed to facilitate its removal for periodic inservice inspections.

Insulation used for the reactor coolant system is strictly specified to limit chlorides and other halogens.

Reactor vessels are frequently insulated with reflective metal insulation systems.

### VALVES

All valves in contact with reactor coolant are constructed primarily of austenitic stainless steel and employ special materials such as corrosion resistant hard surfacing and packing. Back seats and stem leakoffs reduce leakage to the containment to essentially zero.

The pressurizer safety valves are spring loaded and self-actuating, with back pressure compensation. The pressurizer also has power operated relief valves which operate automatically to prevent overpressure. Remotely operated stop valves are provided to isolate these relief valves should excessive leakage occur.

Automatic spray valves regulate the pressurizer spray to provide overpressure control. Locally adjustable throttling valves in parallel with the spray control valves deliver a small continuous flow through each spray line and the pressurizer.

Local vents permit filling of the system. The piping is arranged so that any liquid discharged through a vent is collected in a container or drain without spilling.

Reactor coolant loop isolation valves may be included in a plant design to facilitate some maintenance operations or operation with a loop out of service.

# **chapter 4**

## **auxiliary fluid systems**

# chapter 4.1

## chemical and volume control system

The Chemical and Volume Control System (CVCS) shown in Figure 4.1-1 is designed to perform the following functions in support of the Reactor Coolant System (RCS).

- Maintains required water inventory in the RCS by maintaining programmed water level in the pressurizer
- Reduces the concentration of corrosion and fission products in the reactor coolant
- Provides a means for filling, draining, and pressure testing the RCS
- In conjunction with the Boron Thermal Regeneration System (BTRS), adjusts the boric acid concentration of the reactor coolant for chemical shim control
- Provides a means for control of RCS chemistry
- Provides high-pressure seal water for the reactor coolant pump (RCP) seals

### SYSTEM DESCRIPTION

During power operation, a continuous feed-and-bleed stream is maintained to and from the RCS. The feed rate to the RCS is automatically controlled by pressurizer water level while the

bleed rate can be set by selecting the proper combination of letdown orifices to meet plant operational requirements. Letdown water leaves the RCS and flows through the shell side of the regenerative heat exchanger where it gives up its heat to makeup water being returned to the RCS. The letdown water then flows through letdown orifices where its pressure is reduced, then through a non-regenerative heat exchanger, followed by a second pressure reduction by a low-pressure letdown valve. After passing through a mixed-bed demineralizer where ionic impurities are removed, the water flows through the reactor coolant filter and into the volume control tank via a spray nozzle. An alternate path downstream of the mixed-bed demineralizers can be used to direct the letdown flow to the Boron Recycle System (BRS). The vapor space in the volume control tank contains hydrogen which dissolves in the coolant and determines the hydrogen concentration in the RCS. Any fission gases present are removed from the system by venting of the volume control tank continuously, intermittently, or prior to plant shutdown. Continuous purging of the volume control tank considerably reduces the activity level of the reactor coolant.

The charging pumps take the coolant from the volume control tank or the BTRS and send it along two parallel paths: back to the RCS through the tube side of the regenerative heat exchanger and to the seals of the reactor coolant pumps. The reactor coolant pump seal injection flow enters the pump between the labyrinth seals and the No. 1 seal. Here the flow divides with some water flowing into the RCS and the remainder leaving the pumps as controlled seal leakage. From the pumps, the controlled leakage water goes to the seal water heat exchanger and then returns to the charging pump suction for another circuit. If the normal

letdown and charging path through the regenerative heat exchanger is not operable, water injected into the RCS through the reactor coolant pump seals is returned to the charging pump suction through the excess letdown heat exchanger and seal water heat exchanger.

Surges in the RCS volume are normally accommodated by the pressurizer. However, the volume control tank is designed to allow for pressurizer level mismatches that may occur. If the volume control tank is full, a high-water level signal diverts letdown flow to the Boron Recycle

or Waste Processing System. Low-level signals from the volume control tank initiate reactor makeup control or flow from the refueling water storage tank as a backup.

Makeup to the RCS can come from the following sources:

- Demineralized and deaerated water supply used to reduce the concentration of dissolved boric acid in chemical shim in order to accommodate core burnup

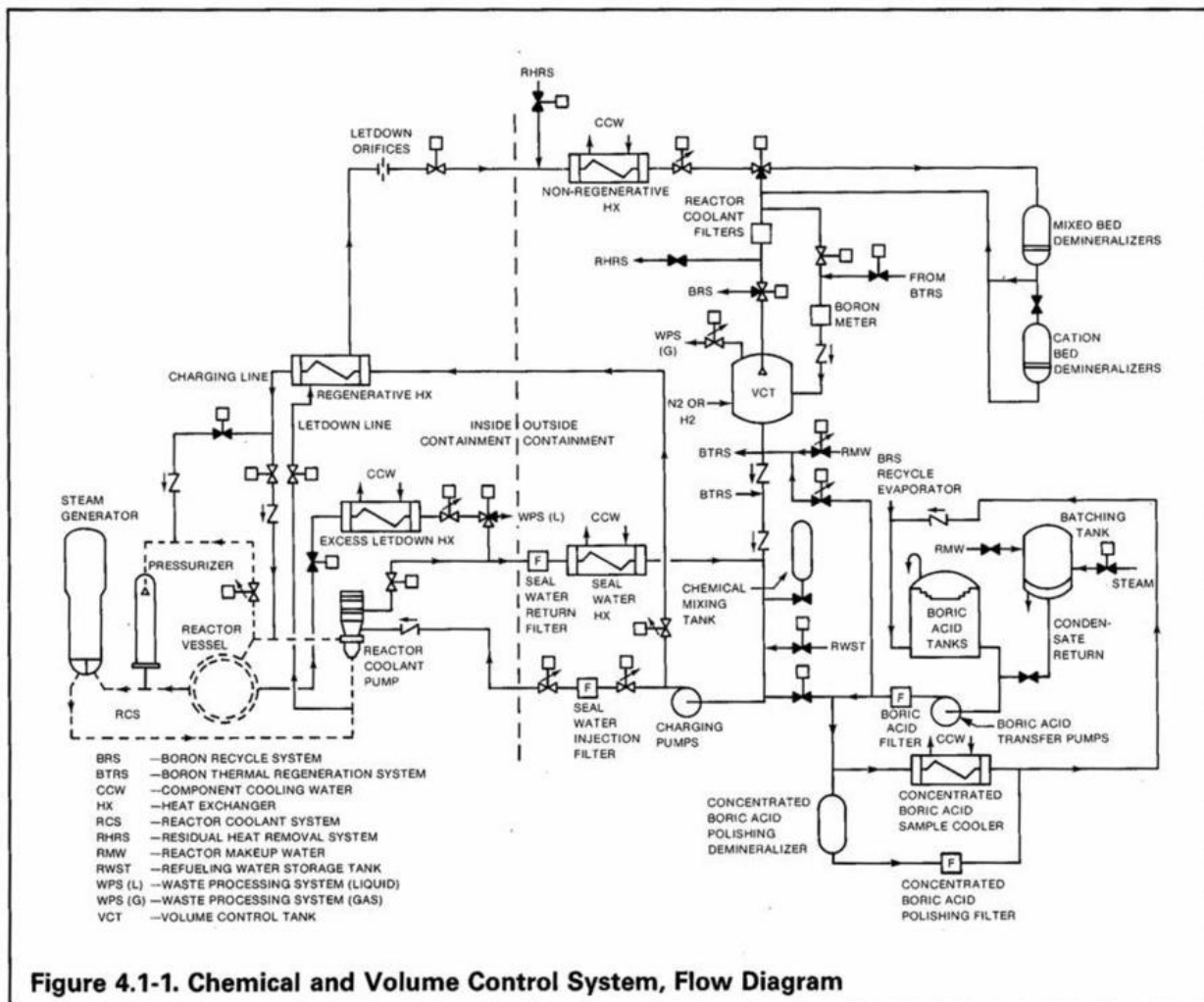



- Chemical mixing tank to add small quantities of hydrazine for oxygen scavenging or lithium hydroxide for pH control
- Refueling water storage tank for emergency makeup of borated water
- Boric acid from the boric acid tanks
- A blend of demineralized and deaerated water and concentrated boric acid to match the reactor coolant boron concentration for normal plant makeup.

A continuing source of clean water and concentrated boric acid solution must be provided to replenish these sources.

An alternate flow path downstream of the volume control tank directs the charging pump suction flow to the BTRS to effect boron concentration changes during load follow operations and other plant operations. Refer to Chapter 4.2 for additional description of the BTRS.

A boron concentration meter provides accurate measurement and monitoring of boron concentration in the reactor coolant. The readout provides control information which the plant operator can utilize in routine operations with makeup, letdown, chemical treatment of reactor coolant, and the regulation of boron concentration. This data also is used in a boron follow program to assist the operator during various boron concentration changes, for example, load follow, fuel burnup, hot standby, and cold shutdown. Sample points for the measurement unit are located upstream and downstream of the boron thermal regeneration demineralizers.

Provisions are also included for boric acid purification. Concentrated boric acid is passed through a demineralizer to remove water-borne impurities such as aluminum, calcium, and magnesium. A filter is also provided for removal of suspended solids.

## SYSTEM OPERATION

### Plant Startup

Charging flow is initiated and the normal letdown flow path is established through the letdown orifices. During the early phases of startup, differential pressures across the orifices will be low and pressure control will be by means of the bypass control between the RHRS and CVCS. Pressure in the RCS is automatically regulated by throttling of the low-pressure letdown valve until a bubble is established in the pressurizer. When a pressure adequate to meet reactor coolant pump net positive suction head and pump seal requirements has been attained, the pumps are operated to sweep any entrained gases from the RCS during the venting operation. After the filling and venting operations have been completed, all reactor coolant pumps are started and the residual heat removal operation is discontinued.

The pressurizer heaters are kept energized to raise the pressurizer liquid temperature to a level where the resultant saturation pressure in the pressurizer is adequate to support operations. The charging pump flow and low-pressure letdown valve are controlled manually to obtain the desired pressurizer water level. The charging flow control then maintains normal pressurizer water level automatically.

A hydrogen blanket is established in the volume control tank by raising the tank water level and purging with nitrogen gas. As the water level is lowered, a gas blanket of hydrogen is introduced.

The boron concentration in the reactor coolant is adjusted to the point where the control rods may be withdrawn to the desired position and criticality achieved. Reactor coolant makeup control is operated to adjust boron concentration and thus maintain the desired control rod position. As the heatup progresses, the system is used to adjust the chemistry of the reactor coolant. Chemicals are added from the chemical mixing tank as required to control reactor coolant pH and dissolved oxygen.

When reactor pressure has been increased sufficiently, the standby orifices are closed to restrict letdown flow to within normal limits. The reactor makeup control is then set for the desired reactor coolant boron adjustment.

### **Normal Operation**

The charging flow controller keeps the pressurizer water level at the programmed setpoint for the reactor coolant average temperature being maintained. At a constant power level, the letdown flow equals the charging flow plus the portion of RCP seal injection flow entering the RCS. The letdown flow is first cooled by the charging stream in the regenerative heat exchanger, then reduced to approximately 115°F (46.1°C) in the non-regenerative heat exchanger.

The letdown water passes through one of the mixed-bed demineralizers, through the reactor coolant filter, and then through the spray nozzle into the volume control tank. Hydrogen over-

pressure in this tank maintains the specified concentration of hydrogen in the reactor coolant. From the volume control tank, a centrifugal charging pump delivers the reactor coolant to the RCP seals and to the regenerative heat exchanger, where it is reheated before being returned to the RCS.

During periods of plant loading, the reactor coolant expands as its average temperature rises. The pressurizer absorbs this expansion as the level controller raises the level setpoint during the load increase. Any coolant not accommodated in the pressurizer is sent to the volume control tank. During this period, the flow through the letdown orifice remains constant and the charging flow is reduced by the pressurizer level control signal, which results in an increased temperature at the regenerative heat exchanger outlet. The temperature controller, downstream of the letdown heat exchanger, increases the component cooling water flow to maintain the desired letdown temperature of approximately 115°F (46.1°C). If the letdown temperature exceeds 140°F (60°C), the letdown flow automatically bypasses the demineralizers.

During periods of plant unloading, the reactor coolant contracts as its average temperature decreases. Coolant contraction is accommodated by the pressurizer and the charging system.

The charging pumps supply water as required for the reactor coolant pump seals as well as the charging flow required for maintaining the pressurizer level. The portion of the flow that passes through the labyrinth seals enters the RCS. The remainder of the flow, after being throttled at the controlled leakage seal, returns to the charging pump suction through the seal water filter and the seal water heat exchanger,

where the temperature is reduced to the volume control tank operating temperature.

During normal power operation, the charging pump suction flow is passed through the BTRS whenever boron concentration changes are desired for load follow and other plant operations. This flow exits from and returns to the charging pump suction line downstream of the volume control tank. A valve in the charging pump suction line is used to direct the charging pump suction flow to the BTRS. Refer to Chapter 4.2 for more details of BTRS operation.

During normal plant operation, the BTRS is employed to compensate for the reactivity effects associated with fuel burnup and fission product buildup and decay, which results in little or no diversion of coolant to the BRS. During the core cycle, the BTRS may not completely handle all fuel burnup and plant startup boron changes. In that case the reactor makeup control is employed and a portion of the reactor coolant letdown flow is diverted to the BRS.

The CVCS is not used to compensate for short-term transients, such as the reactivity effect associated with the Doppler phenomenon.

Changes in the reactor coolant lithium hydroxide or hydrogen concentration are performed under manual control. A solution containing the necessary amount of lithium hydroxide is poured into the chemical mixing tank from where it is injected into the charging pump suction line. Adjustments in the hydrogen concentration are made by changing the setpoint on the hydrogen supply pressure regulator to the volume control tank.

Concentrated boric acid is purified intermittently during normal operation using the Concentrated Boric Acid Polishing Demineralizer. The process

is initiated administratively depending upon boric acid purity.

## Plant Shutdown

Plant shutdown is defined as the operations that bring the reactor plant from zero power operating temperature and pressure to cold shutdown for maintenance or refueling.

Before a cold shutdown for refueling is initiated, the volume control tank overpressure is reduced in order to lower the RCS hydrogen gas concentration. This requirement may also apply to cold shutdowns for maintenance purposes.

Before cooldown and depressurization of the reactor plant is initiated, the reactor coolant boron concentration is increased to the cold shutdown value. Borated liquid for refueling operations is supplied from the boric acid tanks. After boration to cold shutdown concentration is completed and reactor coolant samples verify that the concentration is correct, the CVCS provides additional makeup during cooldown.

Contraction of the coolant during cooldown results in actuation of the pressurizer level control to maintain a normal pressurizer water level. The charging flow is increased, relative to letdown flow, and results in a decreasing volume control tank level. The volume control tank level controller automatically initiates makeup of boric acid which raises the RCS from the cold shutdown boron concentration to the refueling concentration during the cooldown.

During shutdown, the reactor coolant is continuously purified using the mixed bed and cation bed demineralizers in the CVCS. Connections for this purpose are provided upstream of the letdown heat exchanger and downstream of the reactor coolant filter.

# chapter 4.2

## boron thermal regeneration system

The primary function of the Boron Thermal Regeneration System (BTRS) is to vary the Reactor Coolant System (RCS) boron concentration during reactor power changes which include daily load follow operations. The boron concentration changes are accomplished automatically by the BTRS through an ion exchange (passive) method.

The BTRS makes use of a temperature-dependent ion exchange process in order to both store boron from and release boron to the RCS. Operation of the Boron Recycle System (BRS) and evaporators is not required during normal load follow operation. As a result, there is a significant reduction in the water to be processed during normal plant operations and a reduction in BRS requirements. The BRS provides a diverse and redundant method of making boron concentration changes during load follow operations.

The BTRS can also assist in making RCS boron concentration changes associated with core burnup, shutdowns, and refuelings. Schematics of the BTRS are shown in Figures 4.2-1 and 4.2-2.

### SYSTEM DESCRIPTION

The BTRS makes use of a temperature-dependent ion exchange process in order to

both store boron from and release boron to the RCS without discharging water to the Boron Recycle System (BRS) for later evaporation.

The BTRS, which operates in conjunction with the Chemical and Volume Control System (CVCS), consists mainly of several demineralizers, a chiller unit, a chiller pump, heat exchangers, a BTRS recirculation pump, a BTR filter, valves, and associated piping. This equipment controls the temperature and flow rate of the fluid entering the BTRS demineralizers. An alternate charging pump suction path in the CVCS is provided which allows the flow from the volume control tank (VCT) to pass through the BTRS when boron concentration changes are required. The fluid temperature is reduced to 50°F (10°C) to store boron on the ion exchange resin and thus dilute the reactor coolant. The fluid temperature is raised to 140°F (60°C) to release boron from the ion exchange resin and thus borate the reactor coolant. The rate of boration or dilution is controlled by varying the flow rate through the BTRS demineralizers.

The flow path through the BTRS is different for dilution (storage) than for boration (release). During dilution (Figure 4.2-1), the letdown stream from the VCT enters the moderating heat exchanger, and from there it passes through the letdown chiller heat exchanger. These two heat exchangers cool the BTRS stream to 50°F (10°C) before it enters the demineralizers. The source of cold water for the letdown chiller heat exchanger is a closed-loop circuit consisting of the chiller unit, chiller pump, and chiller surge tank. The letdown reheat heat exchanger is valved out on the tube side during dilution. The temperature of the BTRS stream at the point of entry to the demineralizers is controlled automatically by the temperature control valve

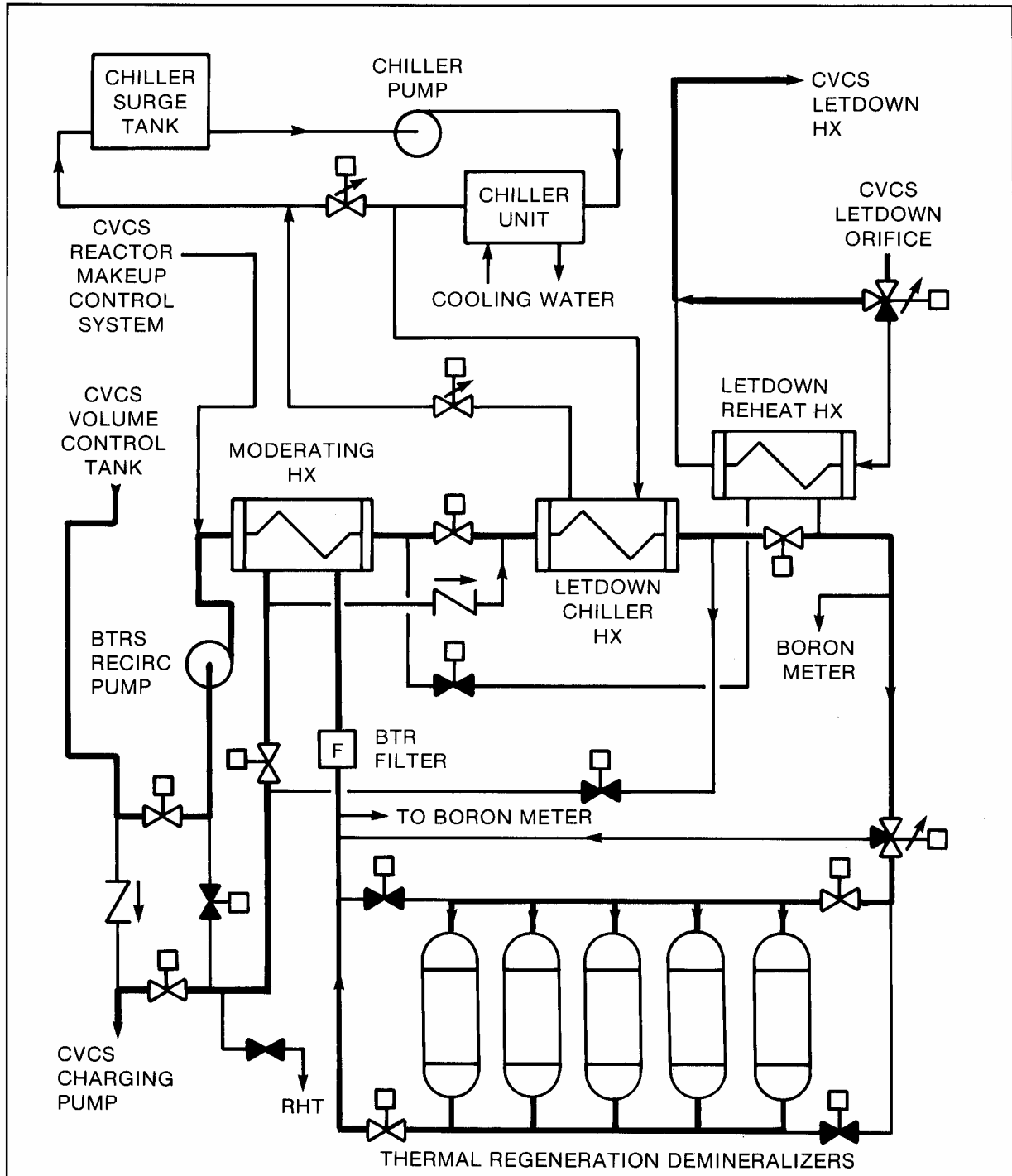

Figure 4.2-1. Boron Thermal Regeneration System (Dilution), Flow Diagram

which controls the shell-side flow to the letdown chiller heat exchanger. The letdown stream passes through the demineralizers and enters the moderating heat exchanger shell side where it is heated by the incoming letdown stream. The flow is then returned to the volume control tank outlet line.

Therefore, for dilution, a decrease in the boric acid concentration in the reactor coolant is accomplished by sending the flow from the VCT, at relatively low temperatures (50°F) (10°C), to the thermal regeneration demineralizers. The resin, which was depleted of boron at high temperature during a prior boration operation, is now capable of storing boric acid from the low-temperature flow from the VCT. Reactor coolant with a lower boron concentration leaves the demineralizers and is directed to the CVCS.

During boration (Figure 4.2-2), the charging pump suction stream enters the moderating heat exchanger tube side, bypasses the letdown chiller heat exchanger, and passes through the shell side of the letdown reheat heat exchanger. The moderating and letdown reheat heat exchangers heat the BTRS stream to 140°F (60°C) before the stream enters into the demineralizers. The temperature of the BTRS stream at the point of entry to the demineralizers is controlled automatically by the temperature control valve that controls the flow rate on the tube side of the letdown reheat heat exchangers. The BTRS stream then passes through the demineralizers, enters the shell side of the moderating heat exchanger, passes through the tube side of the letdown chiller heat exchanger, and enters the charging pump suction. The temperature of the BTRS stream entering the charging pump is controlled automatically by the temperature control valve

that controls the shell-side flow rate on the letdown chiller heat exchangers.

Thus, for boration, an increase in the boric acid concentration of the reactor coolant is accomplished by sending the flow from the VCT, at relatively high temperatures (140°F) (60°C), to the thermal regeneration demineralizers. The water flowing through the demineralizers releases boron that was stored on the resin at low temperature during a previous dilution operation. The boron-enriched reactor coolant is returned to the RCS via the CVCS.

The BTRS recirculation pump provides the motive force to route flow from the VCT through the demineralizers during boration and dilution modes. When the BTRS is not being used for boration/dilution, it is isolated from CVCS and the recirculation pump can operate to change the temperature of the demineralizer beds for the next anticipated mode of operation. For example, after completion of a dilution mode, with demineralizers at 50°F (10°C), the BTRS recirculation pump is used to increase the temperature of the demineralizers to 140°F (60°C) for the subsequent boration mode.

## SYSTEM OPERATION

The BTRS is controlled from the main control board and by the Integrated Control System. When and how the BTRS is operated is dependent on the plant condition. The BTRS is designed primarily to change the RCS boron concentration during reactor power changes. However, it is also beneficial when a plant is base loading, because the BTRS significantly reduces the effluents to the BRS and the evaporator load by assisting RCS boron concentration changes associated with core

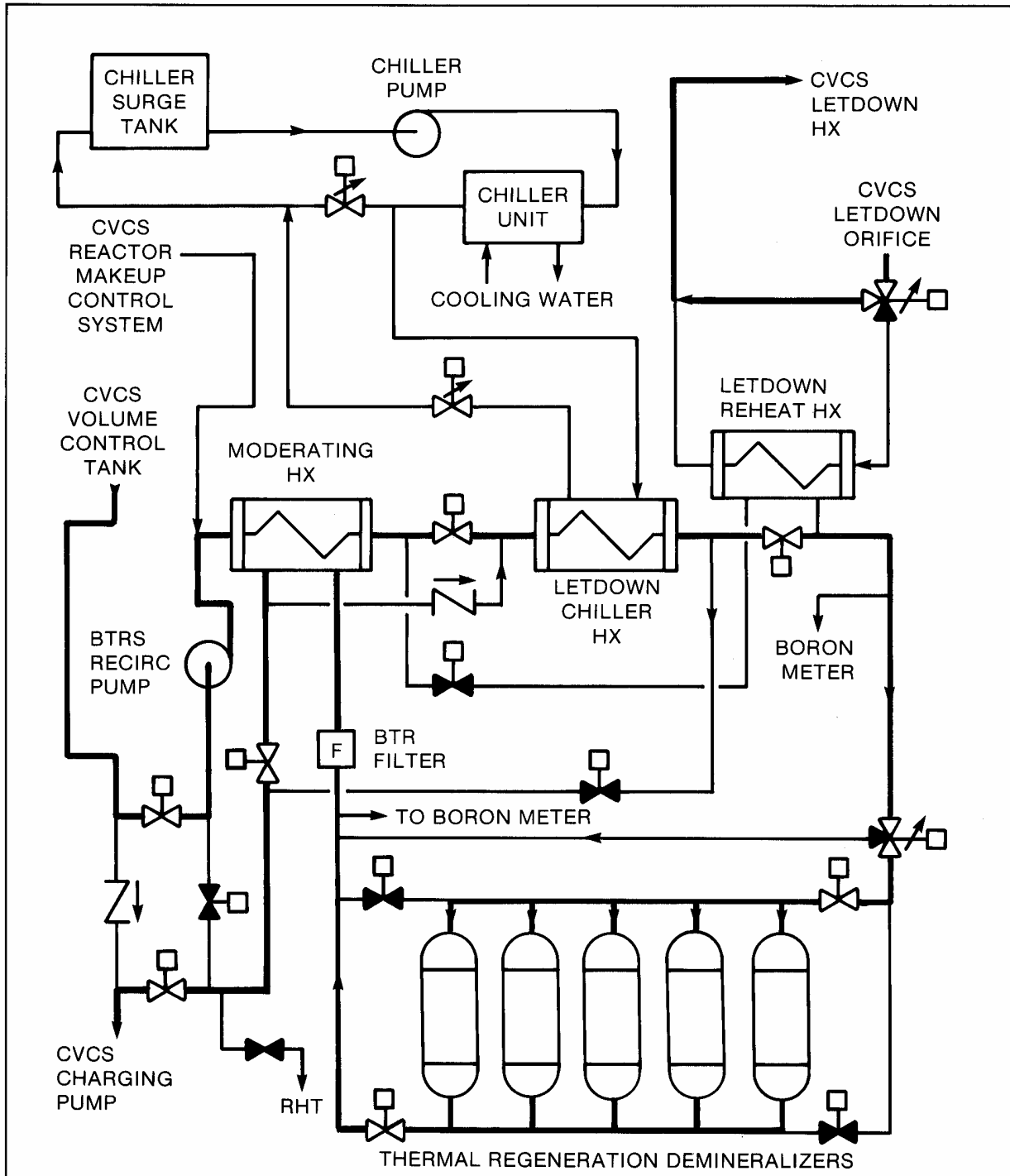

Figure 4.2-1. Boron Thermal Regeneration System (Dilution), Flow Diagram



burnup, hot standby, cold shutdowns, and refueling shutdowns.

### **Plant Startup and Shutdown**

The BTRS can be used during startup and shutdown operation to minimize the amount of effluents sent to the BRS. During plant shutdown, the BTRS can be used to provide some of the boron to meet shutdown boron concentration requirements with the remainder of the boron being supplied from the boric acid tanks. Although there is not a major reduction in effluents during shutdown due to use of the BTRS, this use conditions the demineralizers for the subsequent startup.

Use of the BTRS to dilute the RCS boron concentration during startup will reduce by a factor of two the amount of effluents sent to and processed by the BRS. This is accomplished by operating the BTRS as a concentrating stage in conjunction with the CVCS. Initially the BTRS is operated in a normal dilution mode. The CVCS boron concentration meter is aligned to sample the effluent from the BTRS and can be monitored to indicate the saturation condition of the demineralizer resin beds as boron is stored in the beds. As the beds approach saturation, a dilution operation using the reactor makeup control system is initiated while the BTRS is simultaneously switched to the boration mode.

Because of the influx of makeup water from the reactor makeup control system, the volume control tank level controller automatically diverts the outflow from the BTRS into the BRS holdup tanks. These operations result in effluents of smaller volume and higher boron concentration being sent to the BRS. This operation continues until the resin beds are fully depleted as indicated by the boron concentration meter. The BTRS is then switched from the boration mode back to the dilution mode to remove additional boron from the charging pump suction stream. The reactor makeup control system dilution is also terminated so that letdown will no longer be diverted to the BRS. These steps are repeated until the desired boron concentration is reached.

### **Normal Operation**

During load follow operations, boron concentration changes are accomplished as described above under System Description. The system operation is controlled automatically from the main control board. A master control aligns the BTRS for the mode of operation, that is, boration, or dilution, as required. The control will properly align the system, energize the proper temperature sensors, and start the chiller, chiller pump, and BTRS recirculation pump. When operation of the system is not required, the control switch is placed in the off position.

# chapter 4.3

## residual heat removal system

The primary function of the Residual Heat Removal System (RHRS) is to transfer heat energy from the core and Reactor Coolant System (RCS) during plant cooldown and refueling operations. The system is designed to reduce the RCS temperature to 140°F (60°C) within 20 hours following reactor shutdown. Provisions are made for continued flow of the reactor coolant to the Chemical and Volume Control System (CVCS) during shutdown. The RHRS may also be used to transfer refueling water between the refueling cavity and the refueling water storage tank at the beginning and end of refueling operations.

The residual heat removal pumps and heat exchangers are also utilized as part of the Safety Injection System for emergency core cooling in the event of a loss-of-coolant accident (LOCA). The accident mode of operation is more fully described in Chapter 5.1, Safety Injection System.

A flow diagram of the RHRS is shown in Figure 4.3-1 and represents the configuration for a four-loop NSSS. The configuration for two-loop and three-loop plants differ only in the size of the components and number of branch injection lines to the RCS.

### SYSTEM DESCRIPTION

The RHRS consists of two independent, redundant mechanical subsystems, each of which

receives electrical power from one of two separate and redundant electrical power trains. Each subsystem consists of one RHR pump, one RHR heat exchanger, and the required piping, valves, and instrumentation.

The RHR pumps and heat exchangers are located in the auxiliary building as close as practical to the containment. The piping configurations of the two subsystems are identical with no major piping cross connects between subsystems in the auxiliary building. Each subsystem has a suction line from an RCS hot leg with two normally closed motor-operated series isolation valves providing the isolation necessary to meet the RCS pressure boundary and containment isolation requirements. Each subsystem also has suctions from the containment sump and refueling water storage tank. These suction sources are required by the RHRS for its operation during mitigation of a LOCA as part of the SIS.

The discharge line of each pump is routed to its respective RHR heat exchanger and thence into the containment. A bypass loop is provided around the RHR heat exchanger to permit control of RCS cooldown while maintaining a constant total pump flow. A minimum flow for the RHR pump is provided by a recirculation line from the heat exchanger outlet to the pump suction which remains open in all system operating modes.

Inside the containment, each pump discharge is divided into four branch lines. Each branch line delivers to its respective cold leg through the appropriate accumulator discharge line. No cross connects are present between the two subsystems prior to the discharge headers injecting into the accumulator discharge lines. The branch lines inside the containment are

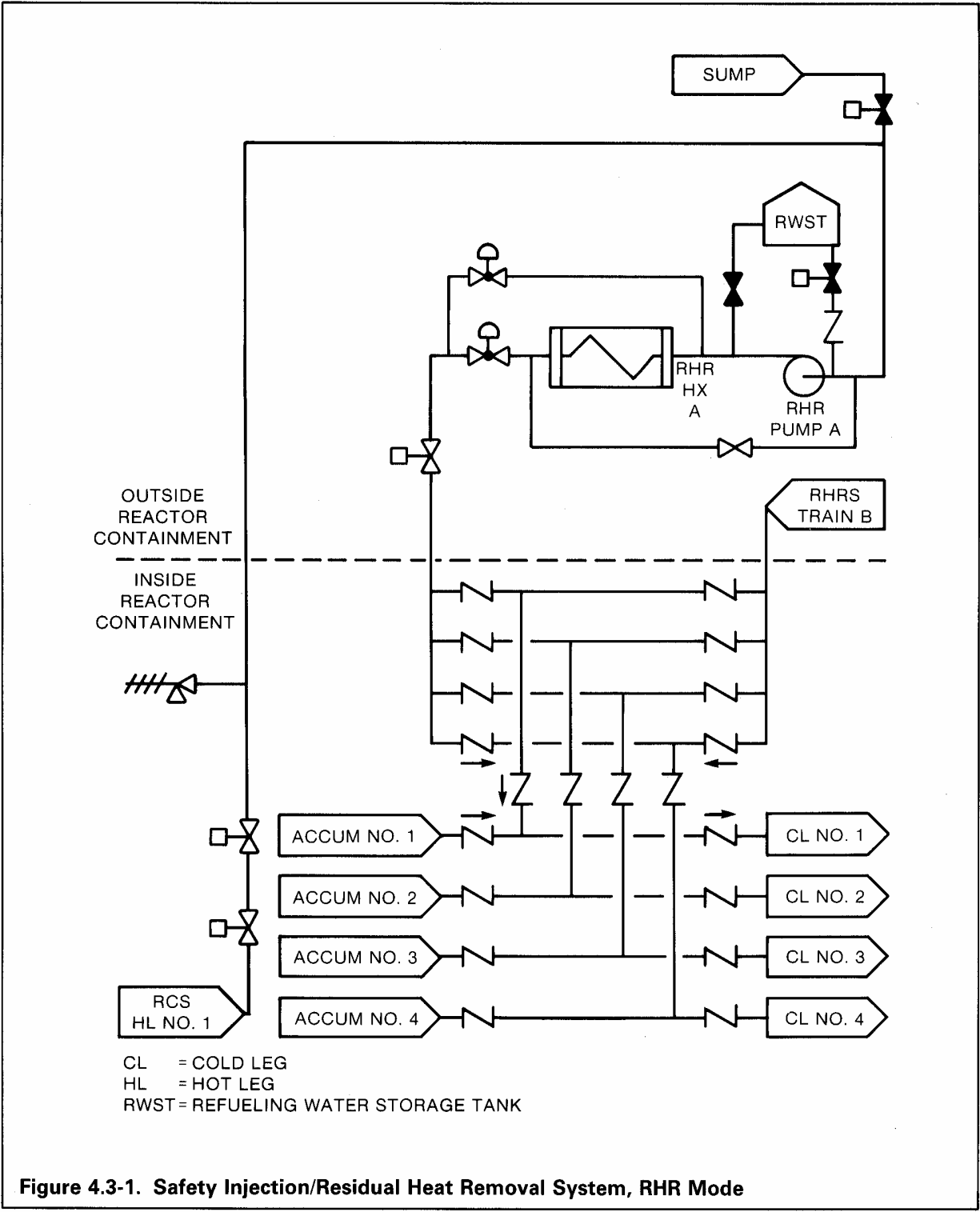

Figure 4.3-1. Safety Injection/Residual Heat Removal System, RHR Mode

isolated from the RCS cold legs by check valves.

During system operation, each RHR pump takes suction from one of the RCS hot legs by its separate suction line. The pumps then discharge flow through the RHR heat exchangers which transfer heat from the hot reactor coolant fluid to the component cooling water circulating through the RHR heat exchanger shell side. The cooled RCS flow is then returned to the RCS cold legs by the shared SIS piping.

## **SYSTEM OPERATION**

### **Plant Startup**

Normally in the cold shutdown condition, one RHR train continues in service to remove decay heat as necessary. The RHR pumps are stopped when the plant startup begins, but the system remains aligned to the RCS in order to take advantage of the capacity of the RHR relief valves to control pressure transients until a steam bubble is formed in the pressurizer. After the steam bubble is formed, the system is isolated from the RCS and aligned for its safety injection function.

### **Normal Operation**

During normal power operation, the RHRS is not in service but is aligned and ready for safety injection operation as described in Chapter 5.1.

### **Plant Shutdown**

Operation of the RHRS is initiated after the control rods have been inserted into the core and the RCS has been borated and partially cooled and depressurized. Initial reactor cooling is achieved by dissipating heat through the

steam generators and discharging steam to the condenser by means of the steam dump system. When the reactor coolant temperature has dropped to 350°F (177°C) and the pressure has been reduced to less than approximately 400 psig (28 bar), the RHR equipment is placed in operation. This reduces the reactor coolant temperature to 140°F (60°C) within 20 hours after shutdown with both RHR pumps and both RHR heat exchangers in operation, and with component cooling water at no more than design temperature being supplied.

RHRS operation generally begins with a short period wherein the pump is run on its miniflow circuit in order to warm the pump and heat exchanger and avoid sudden thermal expansion within these components upon contracting hot reactor coolant. Following system warmup, the block valves in the RHRS suction lines from the RCS are opened and component cooling water circulation is established to the RHR heat exchangers. At this point the reactor cooling function has been taken over by the RHRS, and the steam dump system may be shutdown. One reactor coolant pump is kept running to provide for uniform cooldown of all loops until the cooling temperature is below 160°F (71°C).

The rate of cooldown of the RCS is controlled by use of a remote manual throttle valve to adjust the flow rate of reactor coolant through the RHR heat exchangers. A second flow control valve located in the bypass line around the RHR heat exchangers is automatically positioned by a flow controller that measures flow in the main return line to the RCS. Operation of the controller and bypass valve maintains constant return flow to the RCS. As the reactor coolant temperature decreases, the flow through the heat exchangers is increased to compensate for reduced temperature differences across the heat

exchanger tubes. Bypass flow is then automatically reduced.

Redundancy is provided by the two independent subsystems to provide for reliability of operation, even in the event of failure of a single

component in the fluid system or related control and power supply system to respond actively in accordance with its design function. Failure of either subsystem, or components within the subsystem, may extend the time required to cool down to 140°F (60°C).

# chapter 4.4

## boron recycle system

The Boron Recycle System (BRS) (Figure 4.4-1) collects and processes deaerated reactor coolant effluents for reuse as makeup to the Reactor Coolant System (RCS) as boric acid and reactor makeup water. The BRS provides a means of recycling borated reactor coolant so as to minimize activity releases.

### SYSTEM DESCRIPTION

The BRS normally collects water from the RCS through the Chemical and Volume Control System (CVCS) letdown line. The letdown is diverted to the BRS as a result of changes made to the RCS boron concentration by the CVCS reactor makeup control. In addition, the BRS collects the overflow of the RCS during heatup operations. These occur during such operations as plant shutdown and startup, refueling, and dilution resulting from the slow burnup of the core. Normally, all boron changes required for load changes are made by the Boron Thermal Regeneration System (BTRS) with no discharges to the BRS. However, as a backup to the BTRS, boron concentration changes for load follow can be made by using CVCS makeup and by discharging reactor coolant effluent to the BRS for processing. The BRS, by means of demineralization, gas stripping, and evaporation, reclaims the boric acid and the primary water.

Letdown reactor coolant from the CVCS and deaerated liquid drains is passed through the recycle evaporator feed demineralizers where lithium and fission products are removed. The fluid then flows through a recycle evaporator

feed filter and into the recycle holdup tanks. The borated liquid is then pumped to the recycle evaporator package by one of the recycle evaporator feed pumps. Here hydrogen and residual fission gases are removed in the stripping column before the liquid enters the evaporator shell. The evaporative process produces a batch of 4-weight-percent boric acid solution.

Distillate from the evaporator is pumped to the evaporator condensate demineralizer and then to the reactor makeup water storage tank. Also located in this flow path is a recycle evaporator condensate filter.

To provide that the reactor makeup water storage tank will not become contaminated, a scintillation counter is located in the line leading into the tank. A high radiation level signal at the monitor directs distillate back to the recycle evaporator feed demineralizer.

Concentrates at 4-weight-percent boric acid are normally pumped to the boric acid tanks through the recycle evaporator concentrates filter. If for some reason the boric acid cannot be discharged to the boric acid tanks, it can be diverted back to the recycle holdup tanks. A small sidestream is routed to the reactor makeup purity monitoring system. This system is provided to monitor the condensate from the recycle evaporator to ensure that it conforms with chemical specifications before flowing to the reactor makeup water storage tank.

### SYSTEM OPERATION

The BRS is manually operated from the boron recycle panel. Its operation is similar during all phases of plant operation; however, the duty on the system depends on the plant operation and the use of the BTRS. For instance, use of the BTRS reduces the average evaporator duty from approximately 10 gpm (38 l/m) to less than 2 gpm (8 l/m) per unit.

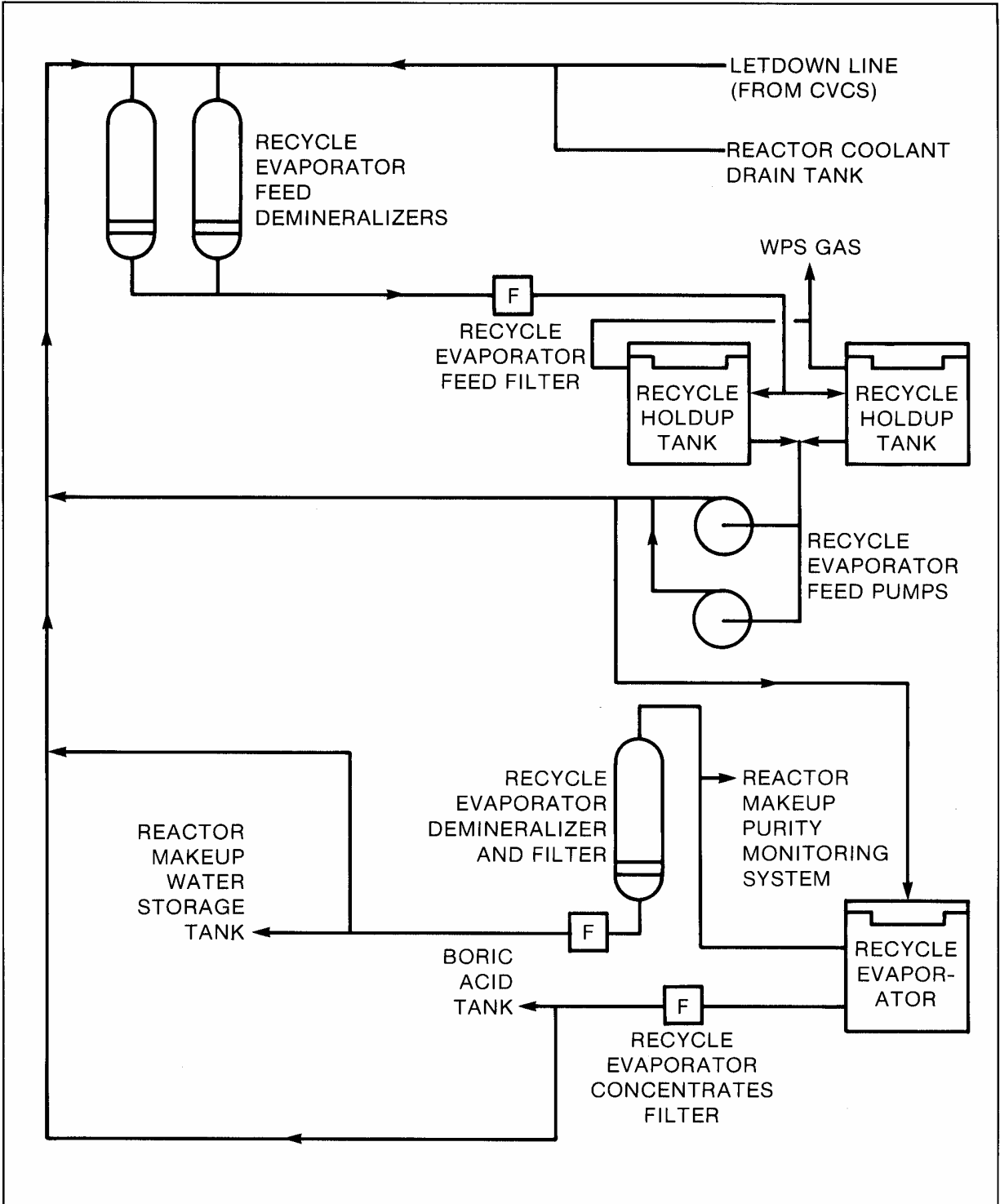

Figure 4.4-1. Boron Recycle System, Flow Diagram



# chapter 4.5

## steam generator blowdown processing system

The Steam Generator Blowdown Processing System (SGBPS) shown in Figures 4.5-1 and 4.5-2 processes blowdown from steam generators to meet chemical specifications that are suitable to allow recycle into the main condenser and to meet radiochemical specifications that are suitable for discharge to the environment when discharge is required.

### SYSTEM DESCRIPTION

During normal operation, blowdown from each steam generator enters a heat exchanger where the temperature is reduced by condensate water. The flows are then measured before being manifolded. The pressure is reduced, and the blowdown is directed through the prefilter and mixed bed demineralizers in series. The fluid flows through a radiation monitor and is normally recycled to the main condenser, but may be discharged to the environment through the discharge canal when required.

Instrumentation is provided at strategic points to monitor the functional integrity and operating efficiency of the system. An increase in conductivity, indicated at the outlet of each demineralizer, signals resin bed exhaustion. When the upstream bed is exhausted, flow is directed around that bed. With the aid of the

spent resin sluice pump, spent resin is transferred to the spent resin storage tank, and new resin is charged to the demineralizer. This fresh demineralizer is then valved back online as the new downstream bed. Before resin disposal, the spent resin storage tank is fluidized with nitrogen gas or sluice water to loosen the resin. The tank is pressurized with nitrogen to discharge the resin to the solid waste processing system.

### SYSTEM OPERATION

#### Plant Startup

During startup operations, the steam generators are brought into chemical specification as rapidly as possible. High blowdown rates are the most effective means the operator has of reducing the solids content of the steam generator. Blowdown is initiated slowly to prevent equipment damage in the event that the system has been drained and/or cooled. The individual blowdown line flow control valves and common pressure control valve are then set to allow the maximum blowdown flow for the system at 100 percent steam generator load.

#### Normal Operation

During normal operation, typical blowdown rates are up to about 30 percent of maximum. Pressure changes due to load fluctuations in the steam generator are compensated for by the flow control valves so that the pressure control valve need not be reset. Normally, the cooled, filtered blowdown is demineralized to prepare it for recycle to the condensate train. If discharge is desired, the demineralizers and filters are bypassed. The radiation monitor stops blowdown in response to a high activity signal. In the event of a primary to secondary leak, as would be indicated by the radiation monitor, the demin-

eralizers are put on line. If the demineralizers are already on line and high activity is indicated, the resins would be changed accordingly.

### **Plant Shutdown**

During plant shutdown operations, high blow-down rates may again be required. To prevent

flashing of the condensate at the outlet of the blowdown heat exchanger, adequate backpressure must exist at the point where the blowdown enters the condensate train. This allows the temperature control valves to control within the design flow range, and to prevent excessive flow through the heat exchanger should the valve(s) fail open.

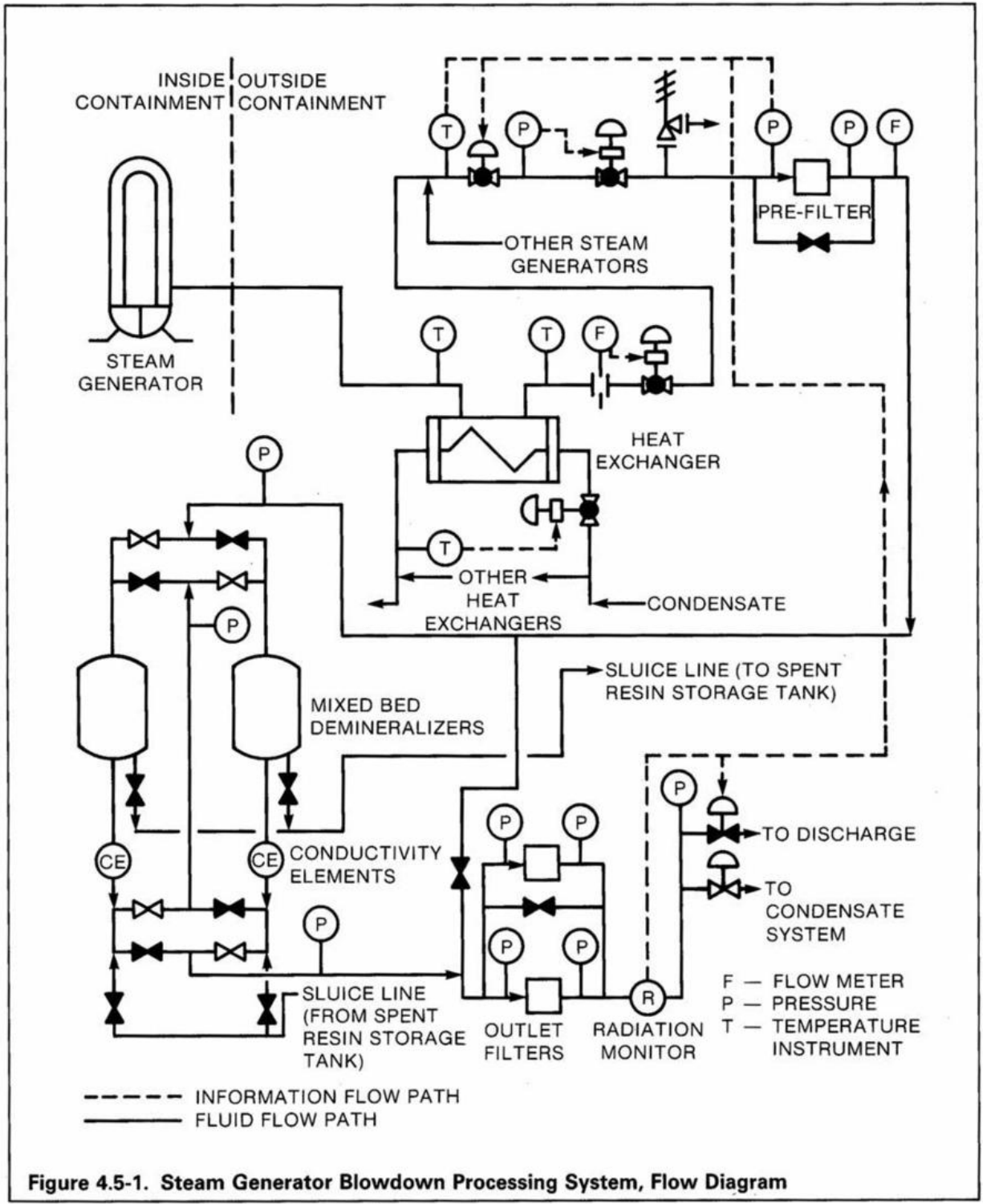
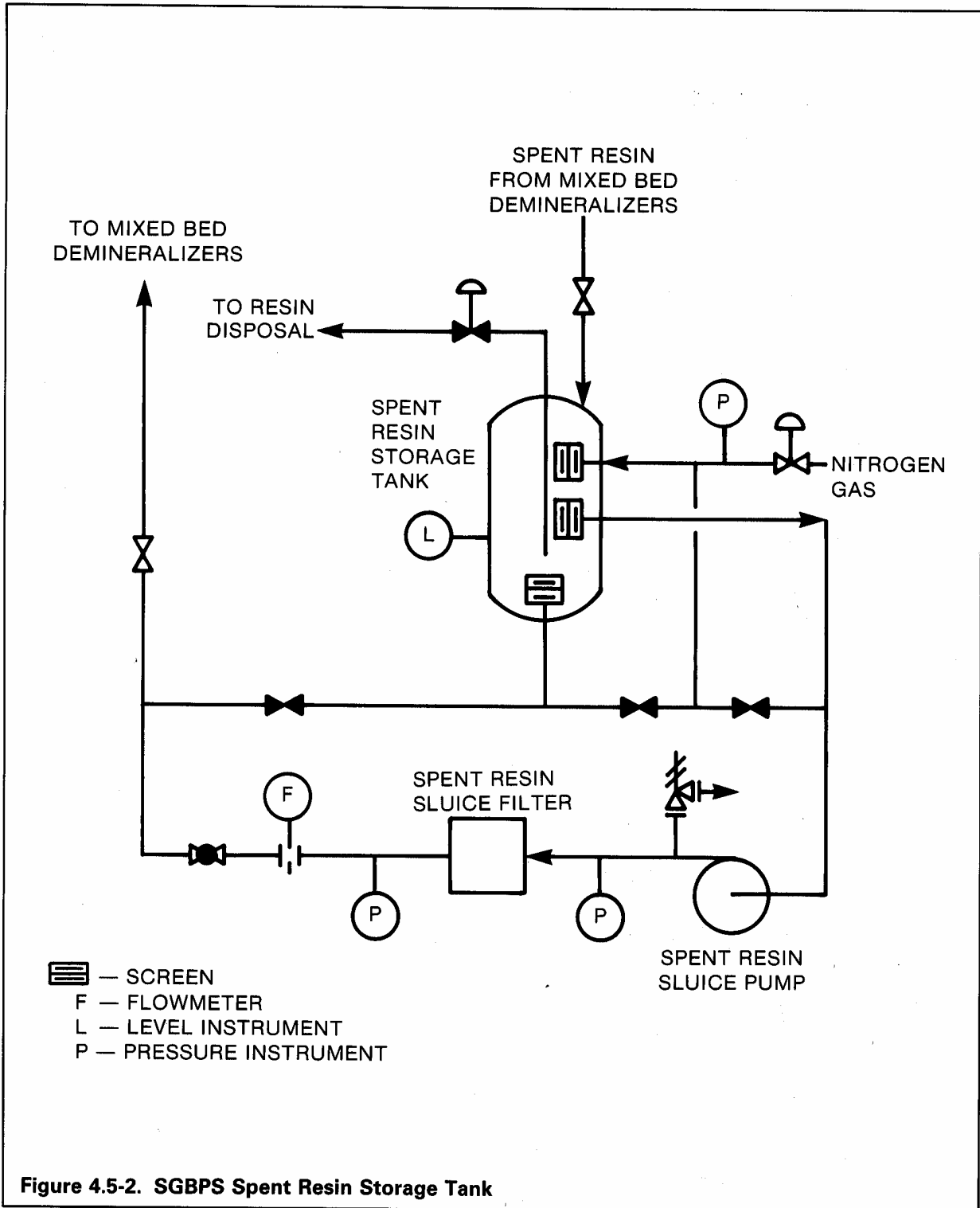

Figure 4.5-1. Steam Generator Blowdown Processing System, Flow Diagram



# **chapter 5**

# **engineered safeguards**

# **systems**

# chapter 5.1

## safety injection system

The Safety Injection System (SIS) has multiple functions. Its primary function is to provide emergency core cooling in the event of a loss-of-coolant accident (LOCA) resulting from a break in the Reactor Coolant System (RCS). The SIS also provides a safety grade method for addition of negative reactivity via injection of borated water to meet shutdown requirements or to compensate for the reactivity increase caused by cooldown transients such as a steam line break. The SIS positive displacement hydrotest pumps also provide a backup source of reactor coolant pump seal injection water, diverse to the CVCS.

In the unlikely event of a LOCA, the SIS is designed to limit increases in fuel clad temperatures, core geometry distortion, and metal-water reaction for all breaks up to and including the double-ended severance of a reactor coolant loop. For the more probable break sizes (less than or equal to 5-inch (12.7cm) inside diameter), the SIS is designed to minimize core damage by providing flow to the core that is sufficient to prevent the mass depletion-related uncovering of the core based on current analytical models. The system is designed to provide not only emergency core cooling but also continued cooling during the long-term phase following the accident. High-pressure safety injection water is provided by separate high-head pumps while lower pressure injection water is supplied by the Residual Heat Removal System (RHRS) pumps. Passive

accumulator tanks are located inside the containment to provide for fast injection of water following a LOCA.

Figure 5.1-1 shows the injection phase of the SIS and is the configuration for a four-loop plant. The configurations for two- and three-loop plants differ only in the size of the components and the number of branch injection lines to the RCS.

### SYSTEM DESCRIPTION

The SIS consists of two independent and redundant mechanical subsystems, each of which receives electrical power from one of two separate and redundant Class 1E electrical power trains, and each of which receives an actuation signal from one of two separate and redundant actuation trains. The major components are two high-head safety injection pumps, two RHR pumps, and four accumulators. There is also a single positive displacement pump which provides emergency injection flow in the event the centrifugal charging pumps are not available. It is not directly associated with either subsystem A or B, and can be powered from either electrical train.

The piping configurations and valving associated with each of the two subsystems are identical. There are no major piping interconnections between the two subsystems in the auxiliary building with the exception of the main supply header from the refueling water storage tank (RWST). Inside the containment, the individual loop injection branch lines from each of the four pumps are directed into a common pipe header and injected into the respective accumulator discharge lines to the RCS cold legs. Each pump delivers to all of the cold legs. Additionally, each subsystem delivers to the hot leg of one loop.

Each of the two mechanical subsystems contains one high-head safety injection (HHSI) pump and one RHR pump. With the exception of drawing from a common suction header from the RWST, these pumps share no piping and are not connected outside the containment. Low-head safety injection is provided by the RHRs. The HHSI pump is a dedicated component of the SIS and does not provide any function required for normal plant operation. This permits the HHSI pump and associated piping to be retained in a ready configuration which only requires the pump to start to initiate safety injection. Each HHSI pump is also provided with a full flow test loop which permits periodic verification of hydraulic performance. Design of the HHSI pump is such that testing or inadvertent start will not result in injection to the

cold leg while the RCS is at normal operating temperature and pressure.

An inadvertent safety injection signal will not result in lifting the pressurizer power-operated relief or safety valves. A continuous minimum flow path which does not require isolation during the injection phase is provided so that an inadvertent pump start will not result in the deadheading of the HHSI pump. Each HHSI pump discharge header feeds each RCS cold leg through individual branch lines.

Redundancy of the two independent subsystems is incorporated to provide for reliability of operation and continued core cooling, even in the event of a failure of a single component in the fluid system or related control and power supply

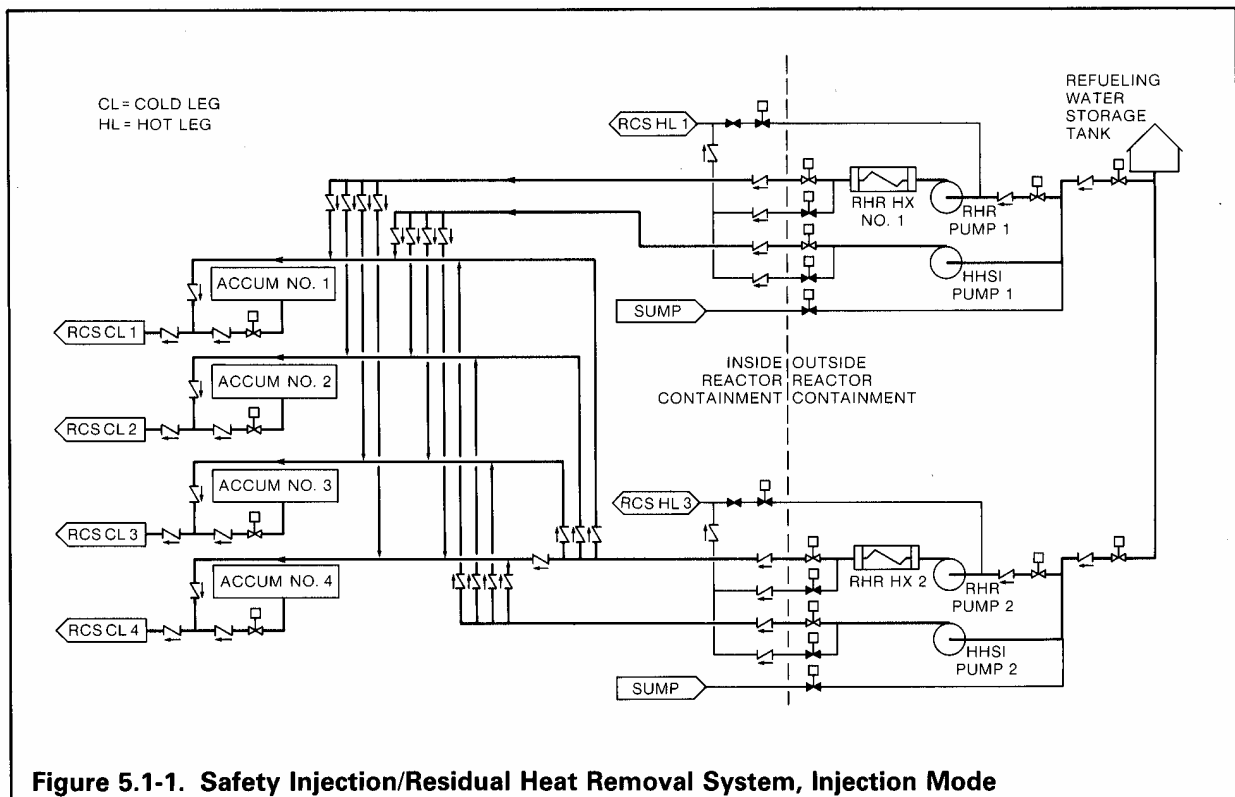



systems to respond actively in accordance with its design function. Both the HHSI and the RHR pumps can take direct suction from the containment sump thereby increasing the system reliability for long-term post-accident recirculation. The HHSI and RHR pumps and all motor-operated valves, except the normally open accumulator isolation valves, are located outside the containment to provide for ease of access for maintenance. The accumulator tanks are passive components normally requiring no maintenance, and are located inside the containment to provide rapid injection of water following a LOCA.

## SYSTEM OPERATION

The operation of the SIS following a LOCA is described in the following paragraphs in three distinct phases:

- Injection phase
- Cold-leg recirculation phase
- Cold-leg and hot-leg recirculation phase

In addition, this system can be operated with a nonfaulted RCS to provide an alternate source of borated makeup water injection. This function is described separately in the following paragraphs.

### **Injection Phase After Loss of Reactor Coolant (Figure 5.1-1)**

The principal mechanical components of the SIS that function immediately following a LOCA are the accumulators, the HHSI pumps, the RHR pumps, the RWST, and the associated piping and valves. Since the SIS components have no active function during normal power operation, they are maintained in a configuration aligned for safety injection immediately upon pump start;

only check valves are required to change position.

For large pipe ruptures, the RCS would be rapidly depressurized and voided of coolant. A high flow rate of emergency coolant would therefore be required to quickly recover the exposed fuel rods to limit possible core damage. This high flow is provided by the accumulators, followed by the HHSI and RHR pumps, all discharging into the cold legs of the RCS. The HHSI and RHR pumps are aligned to take suction directly from the RWST. For smaller breaks, depressurization of the RCS will occur at a slower rate. The HHSI and RHR pumps will be started upon receipt of the actuation signal and will run on miniflow until the RCS pressure falls below the respective shutoff heads of the pumps. Similarly, the accumulator discharge will begin automatically as the RCS pressure decreases below the accumulator tank pressure.

The active safety injection phase is actuated by any one of the following:

- Low pressurizer pressure reported by two out of four signals.
- Excessive cooldown protection signals
  - (1) Low compensated steam line pressure as reported by two out of four signals in any steam line. This protects against secondary breaks during power generation.
  - (2) Steam pressure high negative rate as reported by two out of four signals in any one steam line plus low pressurizer pressure in two out of four channels. This protects against secondary breaks during planned cooldown from power generation.

- High containment pressure as reported by two out of four signals.
- Manual actuation.

The receipt of the safety injection signal initiates the following emergency core cooling actions:

- The onsite emergency diesel generators are started.
- The HHSI pumps are started.
- The RHR pumps are started.

### **Cold-Leg Recirculation Phase Following a Loss of Reactor Coolant**

The changeover from the injection mode to the cold-leg recirculation mode is initiated automatically when the RWST level channels indicate an RWST level less than a low-level setpoint in conjunction with the initiation of the engineered safeguards actuation signal. Protection logic is provided to automatically open the recirculation valve in each of the SIS subsystems when the above signals are generated. To prevent backflow to the RWST of contaminated water from the containment sump, the HHSI pump miniflow isolation valves are automatically closed at this time.

This automatic action would align each of the SIS subsystems for cold-leg recirculation. In this mode, both the HHSI and RHR pumps for each subsystem take suction directly from one of the two containment sump recirculation lines. All pumps will continue to operate and will deliver water to the RCS cold legs without interruption

throughout the automatic recirculation switch-over operation. As in the injection phase, no operator action is required to initiate realignment of either of HHSI or the RHR pump. Furthermore, each pump draws directly from the containment sump and operates independently of the operation of any other pump.

### **Simultaneous Cold-Leg and Hot-Leg Recirculation Phase Following a Loss of Reactor Coolant**

Approximately 24 hours after the switchover to cold-leg recirculation, simultaneous flow to the RCS cold legs and hot legs is established for the purpose of long-term core cooling. The alignment of the HHSI pumps and the RHR pumps remains essentially the same as during the cold-leg recirculation phase, except that a substantial portion of the flow is directed to the RCS hot legs. The purpose of the change in flow alignment is to provide for termination of boiling and to prevent any buildup of boron from interfering with core cooling following a large cold-leg break. Switchover to this phase is performed manually from the control board.

### **Alternative Makeup Supply**

The HHSI pumps also serve as safety grade backup to the Chemical and Volume Control System charging pumps for RCS boration. Manual starting of the HHSI pumps will result in the injection of borated water as RCS pressure is decreased below the shutoff head of the pump. A manual throttling valve, operable from the main control board, is provided to permit control of the injection flow rate as the RCS pressure is reduced.

# chapter 5.2

## emergency feedwater system

The primary function of the Emergency Feedwater System (EFWS) shown in Figure 5.2-1 is to supply feedwater to the steam generators following accident or transient conditions when the main feedwater system is not available. The EFWS thereby maintains the capability of the steam generators to remove plant stored heat and core decay heat by converting the emergency feedwater to steam which is then discharged to the condenser or to the atmosphere. Although the EFWS is also capable of supplying feedwater to the steam generator during normal plant operations of startup, shutdown, and hot standby, it is normally not used for this service. Instead, a small startup pump(s) is located in the main feedwater system and used to supply the reduced amount of feedwater required during these normal plant operations.

### SYSTEM DESCRIPTION

The EFWS consists of two identical subsystems each of which receives electrical power from one of two separate Safety Class 1E electrical power trains. Each subsystem consists of a primary emergency feedwater tank, one motor driven emergency feedwater pump, one turbine driven emergency feedwater pump, and the required piping, valves, instruments, and controls necessary for system operation. The motor

driven and turbine driven pumps are located in the emergency feedwater pump building. The use of both motor driven and turbine driven pumps satisfies the requirement that the pumps be powered by diverse power sources.

In operation, the emergency feedwater pumps take suction from the primary emergency feedwater tanks and discharge the water into the main feedwater piping between the steam generator feed nozzle and the last check valve in the main feedwater line. Each pump is provided with an orificed recirculation line leading back to the primary emergency feedwater tank. This line provides recirculation flow any time the pumps are operating.

The steam supply line for each turbine driven pump is connected to the main steam line from a steam generator. This line is fitted with a steam admission valve which is a pneumatically operated valve arranged to fail-open on loss of air or electrical power.

A primary emergency feedwater supply tank, to which the suction of the emergency feedwater pumps are normally aligned, is provided in each subsystem. The tanks are safety grade and seismically qualified. Each tank contains a quantity of condensate quality water sufficient to allow the plant to be maintained in hot standby for 13 hours then allow a 5-hour cooldown of the plant to 350°F (176.7°C). The maximum permissible water temperature in the primary emergency feedwater supply tank is 120°F (48.9°C).

An alternate emergency feedwater source (condensate storage tanks) should also be provided. The alternate water source should contain sufficient water to allow the plant to be maintained in hot standby conditions, with one

reactor coolant pump operating, for 2 days (48 hours) beginning 18 hours after reactor trip. The maximum water temperature in the alternate water supply should be 120°F (48.9°C).

Normally open, fail-open, air-operated, flow-modulating valves are located in each pump

discharge line. These valves will be normally full open when the system is activated. The valves are provided to allow operator control of the emergency feedwater flow rates to the steam generators so that, in the long term, steam generator water levels can be restored and maintained in the narrow control range. For

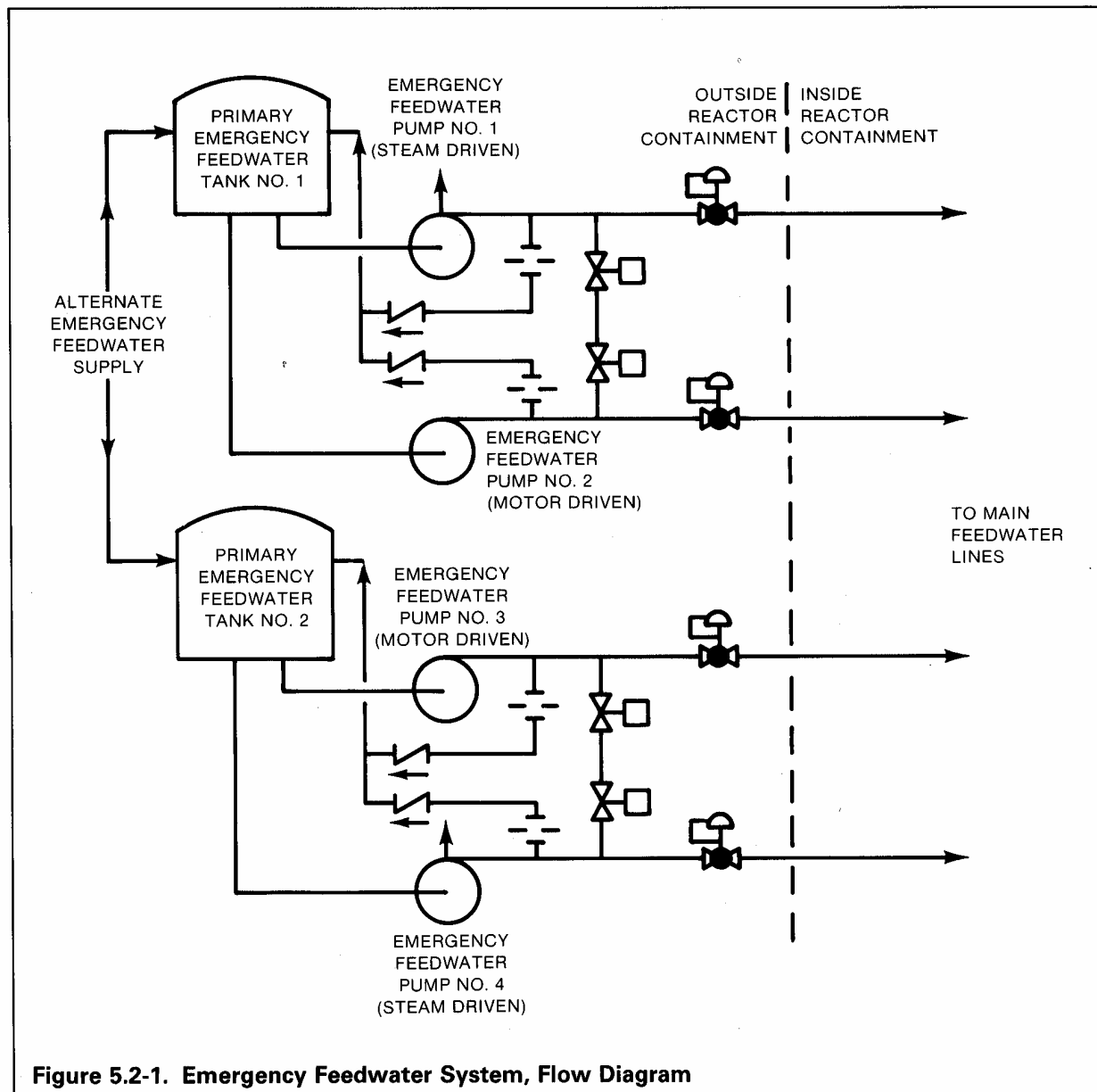

Figure 5.2-1. Emergency Feedwater System, Flow Diagram

conservatism, it is assumed that no operator action can be taken for 30 minutes, and for this period it is assumed that these valves will be full open.

## SYSTEM OPERATION

### Startup

The EFWS can be used to supply feedwater to the steam generators during a plant startup when only small amounts of feedwater are required; however, the system is not normally used for this purpose. Other equipment in the main feedwater system design is provided to supply this reduced amount of feedwater during the plant startup and heatup.

### Normal Operation

The EFWS is not operated during normal plant operations, but remains in a state of readiness to provide emergency feedwater to the steam generators in the event of transient or accident conditions. In the event of such occurrences, the emergency feedwater pumps are automatically started as follows:

Signal	Pumps Started
<ul style="list-style-type: none"> <li>Low-low level in 2/4 level channels in any one steam generator</li> </ul>	Motor driven pumps
<ul style="list-style-type: none"> <li>Low-low level in 2/4 level channels in any two steam generators</li> </ul>	Turbine drive pumps
<ul style="list-style-type: none"> <li>Safety injection</li> </ul>	Motor driven pumps

Since all valves in the system discharge path are open, the automatic startup of the pumps will result in the immediate delivery of emergency feedwater into the steam generators. The system is designed to supply at least the minimum required flow, within one minute of the actuation signal, to at least two effective steam generators (or one effective steam generator in the case of a two-loop plant), and to continue this delivery for an indefinite period without operator action. When operator action can be taken (after an assumed 30-minute delay), the emergency feedwater flow is adjusted by positioning the flow modulating valves to restore and maintain the steam generator water levels within the narrow control range.

With the reactor tripped, and the EFWS supplying water to the steam generators at a rate equivalent to the rate at which steam is being removed to dissipate core decay heat and the heat input of one reactor coolant pump (assumed to be operating), the plant is in a stable hot standby condition. The plant can be maintained in this condition for a period limited only by the amount of water in the primary and alternate emergency feedwater supplies.

If the initiating event can be resolved, plant power operations can be resumed. Normal feedwater flow to the steam generators by the main feedwater system is resumed and the emergency feedwater pumps are manually stopped. If the initiating event cannot be resolved, a plant cooldown must be performed. In this case, the EFWS continues to supply feedwater to the steam generators throughout the cooldown until the primary system hot leg temperature is reduced to 350°F (176.7°C). At this temperature, the Residual Heat Removal System (RHRS) is activated and the EFWS is

secured. The RHR continues the cool-down to cold shutdown conditions.

### **Shutdown**

The EFWS can be used to supply feedwater to the steam generators for normal plant cool-downs. To accomplish this, the pumps are manually started and the flowrates are manually

controlled by positioning the flow modulating valves. When the reactor coolant hot leg temperature is reduced to 350°F (176.7°C) and the RHRS has been activated, the EFWS is secured. The EFWS is not normally used for plant cooldown during shutdown, since other design provisions contained in the main feedwater system should be used to supply the steam generators in this case.

# chapter 5.3

## component cooling water system

The Component Cooling Water System (CCWS) provides a continuous supply of cooling water to plant components which handle potentially radioactive fluids. In doing so it forms an intermediate barrier between these potentially radioactive systems and the Service Water System, thereby reducing the possibility of discharging radioactivity to the environment.

Component cooling water is supplied to NSSS systems as required by the following operations:

- Removal of heat from various components during normal power generation.
- Removal of residual and sensible heat from the Reactor Coolant System through the Residual Heat Removal System during plant cooldown.
- Cooling of safeguards equipment following an accident.

The CCWS is designed to provide cooling for the following components:

- Reactor coolant pumps (RCS)
- Residual heat exchangers (RHRS)
- Residual heat removal pumps (RHRS)
- Letdown heat exchanger (CVCS)

- Excess letdown heat exchanger (CVCS)
- Seal water heat exchanger (CVCS)
- Centrifugal charging pumps (CVCS)
- Control rod drive mechanism coil cooler (RCS)
- Refrigerated dryer
- Recycle evaporator package (BRS)
- Chiller unit (BTRS)
- Waste evaporator package(s) (WPS)
- Waste gas compressor package (WPS)
- Hydrogen monitor
- Reactor coolant drain tank heat exchanger (WPS)
- Spent fuel pit heat exchangers (SFPCS)
- Sample heat exchangers (SS)
- Gross failed fuel detector
- Containment spray pump heat exchangers (CSS)
- Containment fan coolers
- Service air compressor
- Instrument air compressor
- Positive displacement pump (CVCS)

### SYSTEM DESCRIPTION

The CCWS consists of a Safeguards subsystem and an Auxiliary subsystem (Figure 5.3-1).

The CCWS Safeguards subsystem is considered an engineered safeguards system because it is required to remove decay heat during post-accident and to provide cooling water to safe-



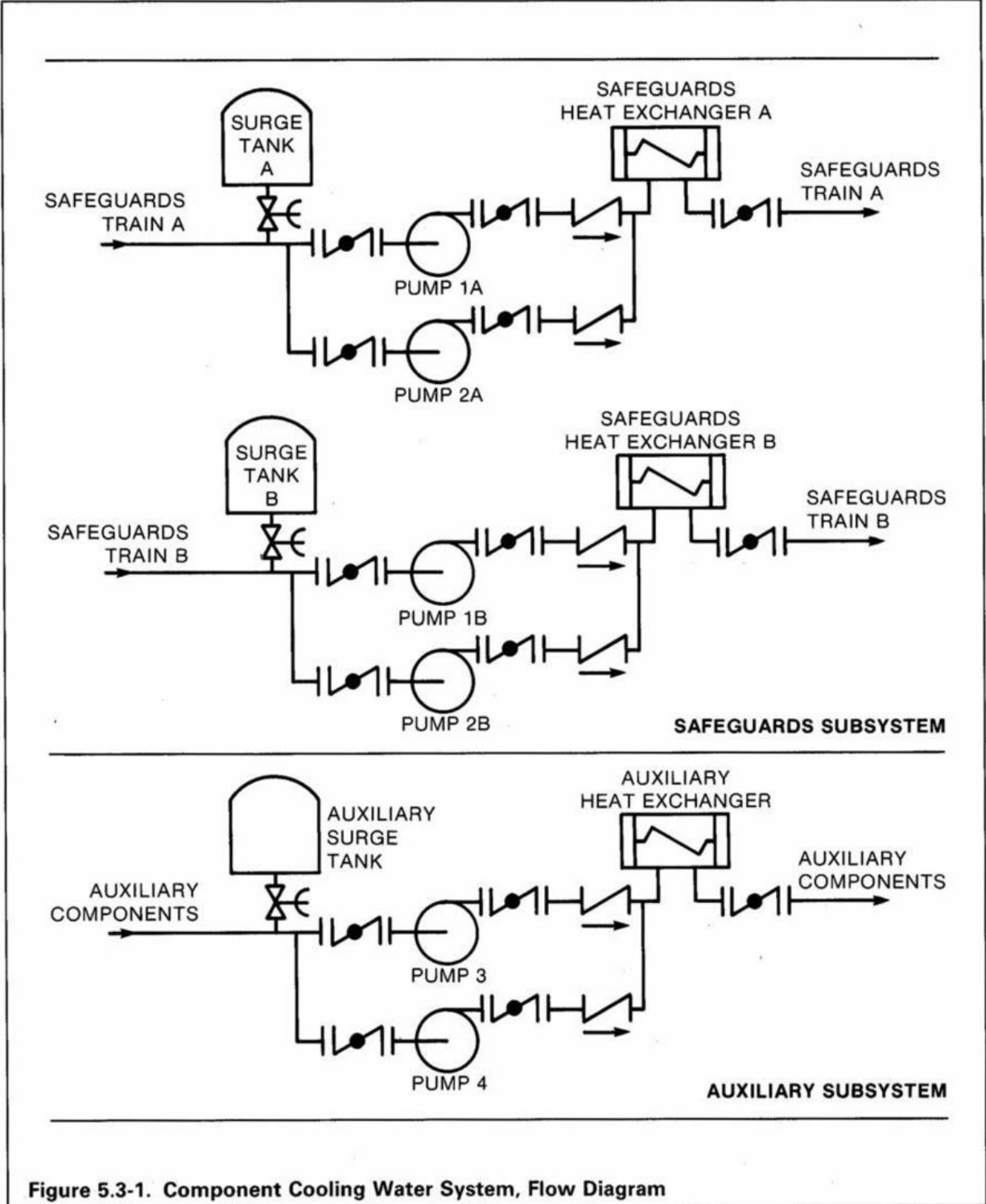

Figure 5.3-1. Component Cooling Water System, Flow Diagram

guards equipment. The subsystem is designed to retain total physical separation consisting of two separate, independent safeguards trains with no cross connection between the two trains. Components of each safeguards train (pumps and heat exchanger) are housed in separate safeguards equipment cubicles. The plant separation facilitates compliance to standards in the area of fire protection, flooding prevention, and plant sabotage.

The Safeguards subsystem is divided into two separate and redundant safeguards trains and provides cooling water to safeguards equipment such as the residual heat removal heat exchangers and pump, the reactor coolant pump thermal barriers, the containment fan coolers, the containment spray pump heat exchangers, the spent fuel pit heat exchangers, and the positive displacement pump. Each safeguards train is sized to supply 100-percent post-accident component cooling flow requirements. Each train consists of two 100-percent capacity component cooling pumps, one 100-percent component cooling heat exchanger, one component cooling surge tank, a chemical addition tank, cooling lines to the various safeguards components, and associated piping, valves, and instrumentation. This arrangement permits single failure criteria to be met with up to one pump per train removed from service for maintenance. The component cooling water flows from the pump, through the shell side of the component cooling heat exchangers, through the components being cooled, and back to the pump. The surge tank is connected to the suction side of the component cooling pumps.

The component cooling Auxiliary subsystem provides cooling water to non-safeguards components in the Chemical and Volume Control System, Boron Recycle System, Waste

Processing systems, and other auxiliary subsystems.

The Auxiliary subsystem provides 100-percent component cooling for normal operation. It consists of two 100-percent component cooling pumps, one 100-percent component cooling heat exchanger, one component cooling surge tank, a chemical addition tank, and associated piping, valves and instrumentations. The subsystem's flow path is similar to that of the Safeguards subsystem.

The surge tanks of both Safeguards and Auxiliary subsystems provide like functions. They provide a surge volume to accommodate thermal expansion and contraction of system volume during transients, and collects water that may leak into the system from components being cooled. The tanks also contain sufficient water volume to provide component cooling water until a design basis passive failure can be isolated.

Water chemistry control of the CCWS is accomplished by chemical additions to the chemical addition tank. A safety grade makeup source is provided by the demineralized water system or reactor makeup system (emergency makeup only) and delivered to the surge tank.

## **SYSTEM OPERATION**

During normal full power operation, one component cooling safeguards train and the component cooling auxiliary subsystem (each operating with one pump and one heat exchanger) are required to accommodate the heat removal loads. The safeguards train services the containment fan coolers, the reactor coolant pump thermal barriers, and the spent fuel pit heat exchangers; the auxiliary train

supplies component coolant to other components required during normal operation.

During plant normal cooldown, the standby train of the Safeguards subsystem is placed in operation at approximately four hours after reactor shutdown. The Safeguards subsystem provides component cooling water flow to the operating residual heat exchangers and pumps. The component cooling water inlet temperature to various components during normal cooldown is permitted to increase to 120°F (49°C), however it must return to 105°F (40°C) after four hours.

Failure of a pump will not affect the time required for cooldown because a standby pump in each train of the Safeguards subsystem is provided. A spare pump is also available in the Auxiliary subsystem. Failure of a safeguards train will not affect the plant's capability to remove decay heat; cooldown time however will be extended.

The CCWS pumps, heat exchangers of the Safeguards subsystem and its associated piping, valves and instrumentations are seismically qualified as required for an engineered safeguards system.

# **chapter 6**

# **containment systems**

Multiple barriers designed into the power plant provide containment of radioactive products at three fundamental levels:

- Zircaloy tubes of the fuel rods
- Reactor coolant system pressure boundaries
- The reactor containment vessel (building)

Diversity of concept, defense in depth, and redundancy of systems as it relates to protection and containment are discussed in other chapters in this book.

This chapter discusses the design of the Reactor Containment Building (hereafter referred as the containment) that will contain and control any release of radioactivity to the environment under normal, upset, or emergency conditions. Also included are containment systems that will protect the integrity of the containment by reducing steam pressure and controlling hydrogen to avoid an explosive mixture. Ventilation systems provided with filters will reduce radioactivity in the containment atmosphere to permit safe access into the containment. The structure provides biological shielding for both normal and accident situations.

## **CONTAINMENT STRUCTURAL DESIGN**

### **General Description**

Several types of containment structures have been designed and proposed to utilities. Those designs in prevalent use incorporate steel vessels or concrete vessels lined with steel plate. Steel vessels can be cylindrical or spherical in shape. Reinforced concrete vessels, which may in some cases be post-tensioned are

cylindrical with hemispherical domes. The type of structure chosen by a utility is dependent on plant layout, site characteristics, and relative costs of alternatives for a particular project.

A typical prestressed concrete containment is shown in Figure 6-1. Figure 6-2 shows a typical cylindrical steel containment.

For reasons of space only a representative example will be described: a prestressed concrete containment (Figure 6-3) having a cylindrical shell, a hemispherical dome, and a flat base slab (with a pit). The inside face of the concrete shell, dome, and floor is steel plate lined to ensure a high degree of leak tightness. Other designs while varying in detail will meet the same functional requirements.

The cylindrical shell is prestressed by a post-tensioning system consisting of horizontal and vertical tendons. The dome has a two-way post-tensioning system. There are three buttresses equally spaced around the containment. Hoop tendons are anchored at buttresses 240 degrees apart, bypassing the intermediate buttress. Each successive hoop is progressively offset 120 degrees from the one beneath it. (Another possible tendon arrangement includes U-tendons and hoops. A third system includes helicoidal tendons in opposite patterns.)

The foundation base slab is a concrete structure conventionally reinforced with high-strength reinforcing steel. A continuous access gallery is provided beneath the base slab for the installation and inspection of vertical tendons. The base liner, installed on top of the structural slab, is covered with concrete for post-tension.

The containment completely encloses the entire reactor and Reactor Coolant System (RCS) and

ensures that an acceptable upper limit for leakage of radioactive materials to the environment would not be exceeded even if gross failure of the RCS were to occur. The approximate dimensions of the containment are: 124 feet (37.8 m) inside diameter, 205 feet (62.5 m) inside height, 3-1/2 feet (1.07 m) wall thickness, and 2-1/2 feet (0.76 m) dome thickness. The internal net free volume approximates 2,000,000 cubic feet (56,600 m<sup>3</sup>).

### Basis for Design Loads

The containment is designed for all credible conditions of loading, including normal loads, loads during loss-of-coolant accident, test loads, and loads due to adverse environmental conditions. The two critical loading conditions are those caused by the design basis accident resulting from failure of the RCS, and those caused by an earthquake.

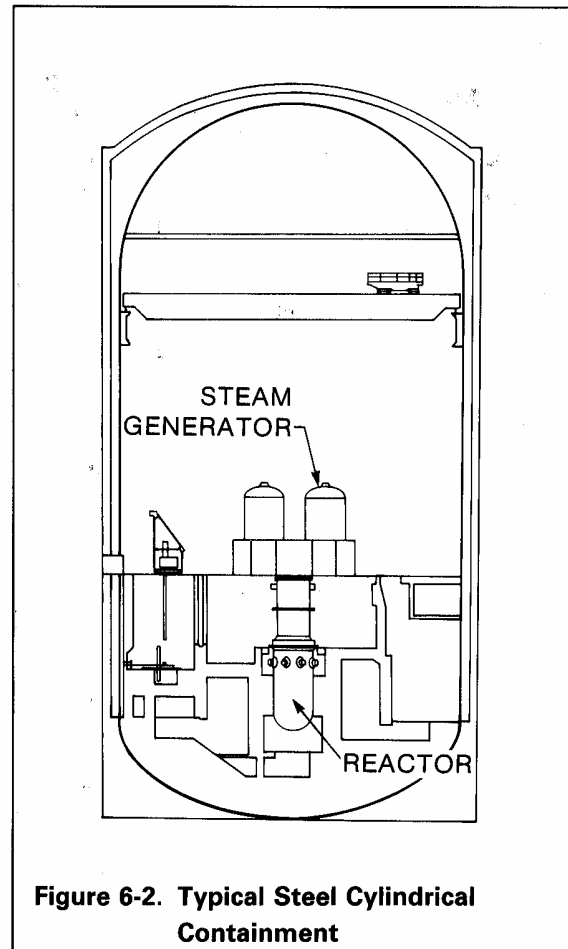
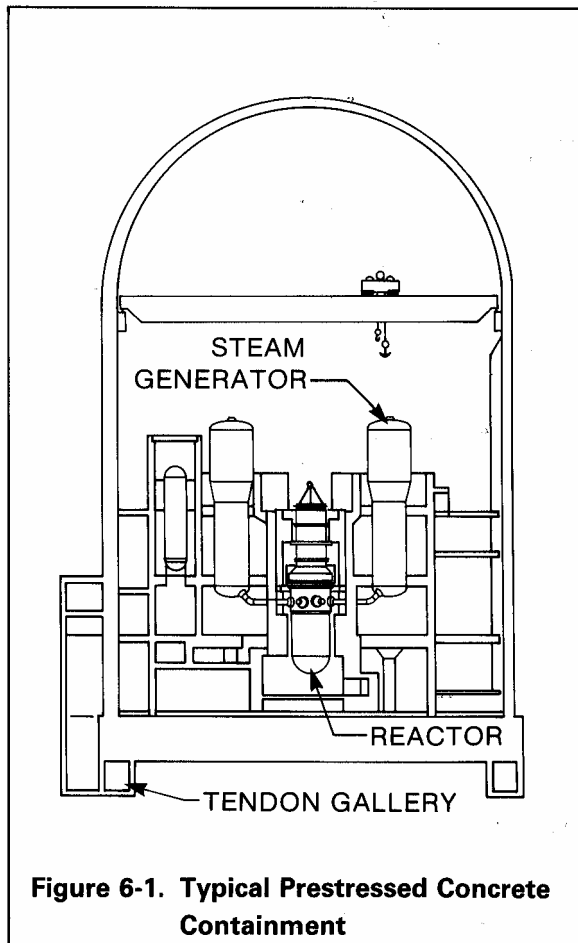

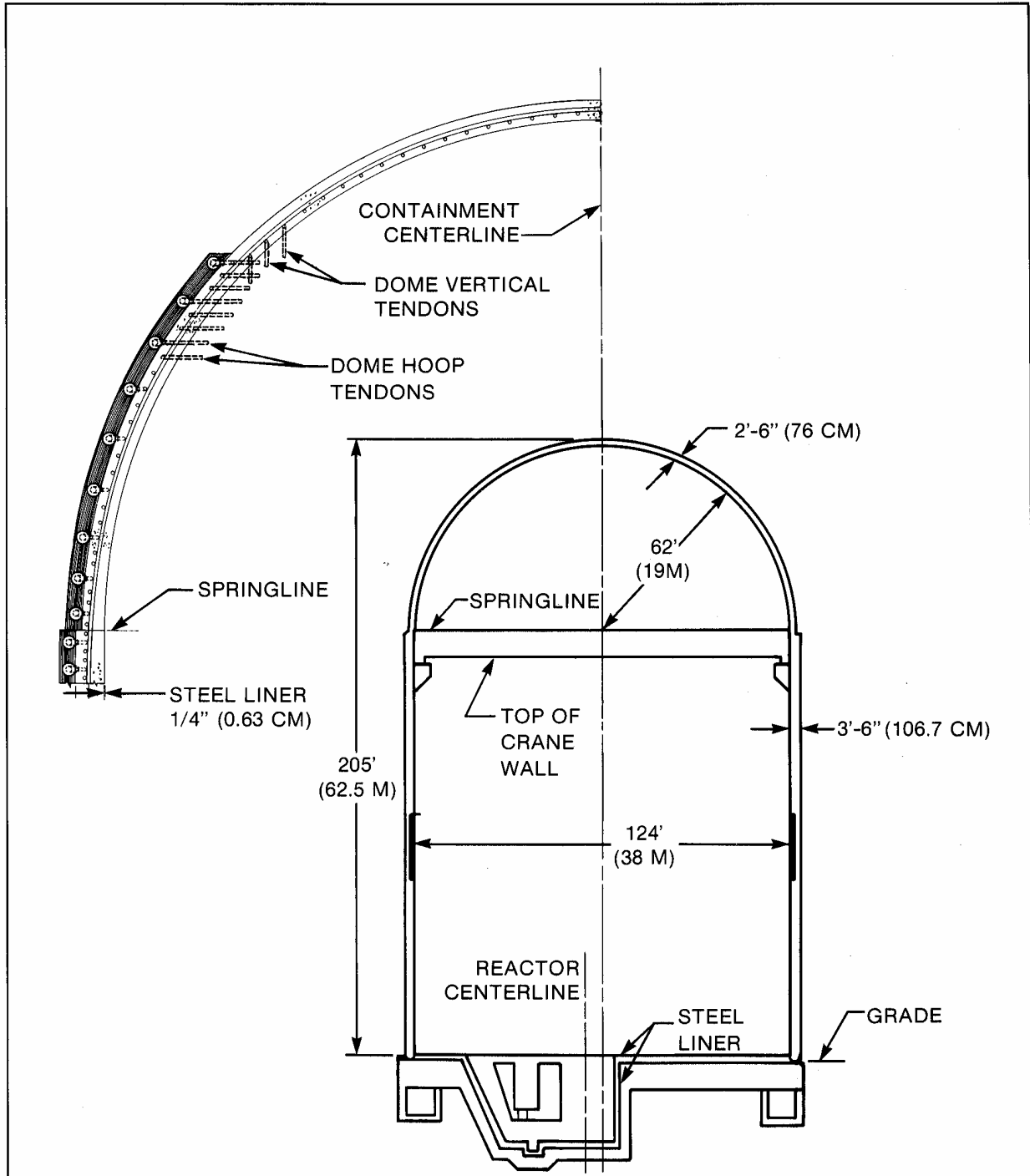

Figure 6-3. Typical Prestressed Concrete Containment, Construction Details



Loading considerations are applied as follows:

**Design Basis Accident (DBA)** – The minimum design pressure and temperature of the containment are equal to the peak pressure and temperature occurring as the result of any rupture of the RCS up to and including the double-ended severance of a reactor coolant pipe. The supports for the RCS are designed to withstand the blowdown forces associated with the sudden severance of the reactor coolant piping so that its coincidental rupture with that of the steam or the feedwater systems is not considered credible. Transients resulting from the DBA serve as the basis for a containment design pressure of 60 psig (4.46 bar). Transients resulting from other accidents could be controlling for specific compartments of the containment.

**Thermal Loads** – The variation of temperature with time and the expansion of the liner plate are considered in designing for the thermal stresses associated with the DBA.

**Dead Loads** – Dead loads consist of the weight of the concrete wall, dome, base slab, internal concrete and permanent equipment, machinery, components, and the like.

**Live Loads** – Live loads consists of all loads except dead, accident, seismic, flood, and wind, and include snow loads on the domed roof of the containment. Live loads are assumed for the design of internal slabs consistent with the intended use of the slabs.

**Earthquake Loads** – Earthquake loading is predicted upon a design earthquake with a ground acceleration equal to the Operating Base Earthquake (OBE) for the site selected. In addition, a maximum hypothetical earthquake

having a ground acceleration equal to the Design Safe Shutdown Earthquake (SSE) for the site selected is used to check the design and ensure no loss of function. A vertical component having a magnitude equal to the horizontal component is applied simultaneously. A three-dimensional dynamic analysis is used to arrive at equivalent static loads for design. Soil-structure interactions are included in the dynamic model.

**Wind Forces** – Wind loading results from site conditions including consideration of hurricane winds. This wind loading is considered for the design of all structures. However, wind loads are not applied simultaneously with seismic loads.

**Hydrostatic Loads** – Uplift forces which are created by hydrostatic pressure are included in the design of all structures.

**External Pressure Load** – External pressure loading with a differential of 2-1/2 psi (0.17 bar) from outside to inside are considered. The external design pressure is also adequate to permit the reactor building to be cooled from an initial maximum operating condition of 120°F (49°C) to an internal temperature during shutdown of 50°F (10°C) (winter).

**Prestressing Loads** – These allow for slip at anchorage, elastic shortening of concrete, creep of concrete, shrinkage of concrete, relaxation of steel stress and frictional losses in the tendon ducts. Load factors are in accordance with the ACI/ASME Code.

### **Containment Design Criteria**

The safety of the structure under extraordinary circumstances and the performance of the containment at various loading stages are the

primary considerations in establishing the structural design criteria.

The two basic criteria are:

- The integrity of the containment liner is guaranteed under all credible loading conditions.
- The structure has a low-strain elastic response such that its behavior is predictable under all design loadings.

The strength of the containment at working stress and overall yielding is compared to the allowable values under the various loading combinations to ensure safety.

To ensure proper performance the analysis and design of the containment is carried out with consideration for strength, the nature and the amount of cracking, the magnitude of deformation, and the extent of corrosion. The structure is designed to meet performance and strength requirements under the following conditions:

- Before prestressing
- At transfer of prestress
- Under sustained prestress
- At design loads
- At factored loads

The base slab acts primarily in bending rather than membrane stress and therefore it is not prestressed.

**Design Method** – The containment shell is analyzed for individual and various combinations of loading cases of dead load, live load, prestress, temperature, and pressure. The

design output includes direct stresses, shear stresses, principal stresses, and displacements of each nodal point.

Stress plots which show total stresses resulting from appropriate combinations of loading cases are made and areas of high stress are identified. If necessary, the modulus of elasticity is corrected to account for the nonlinear stress-strain relationship at high stresses. Stresses are then recomputed if a sufficient number of areas requiring attention exist.

**Containment Liner Criteria** – To meet the specified leak rate under accident conditions the containment liner satisfies the following criteria:

- Containment liner is protected against damage by missiles.
- Containment liner strains are limited to allowable values that have been shown to result in leak tight vessels or pressure piping.
- Containment liner is prevented from developing significant distortion.
- All discontinuities and openings are anchored to accommodate the forces exerted by the restrained containment liner, and careful attention is paid to details at corners and connections to minimize the effects of discontinuities.

The following fatigue loads are considered in the design of the containment liner:

- Thermal cycling due to annual outdoor temperature variations. Daily temperature variations do not penetrate a significant distance into the concrete shell to appreciably change the average temperature of the shell

relative to the containment liner. The number of cycles for this loading will be 40 cycles for the plant life of 40 years.

- Thermal cycling due to containment interior temperature varying during the startup and shutdown of the reactor system. The number of cycles for this loading is assumed to be 500.
- Thermal cycling due to DBA is assumed to be one cycle. Thermal load cycles in the piping systems are somewhat isolated from the containment liner penetrations by the concentric sleeves between the pipe and the liner. All penetrations are verified for a conservative number of cycles to be expected during the plant life.

The containment liner as well as any carbon steel surface exposed to the containment atmospheres is coated with a coating system qualified to resist accident conditions without peeling, scaling or blistering.

#### **Equipment and Personnel Access Hatches –**

An equipment hatch 21 feet (6.4 m) in diameter is provided for access to the containment. It is fabricated from welded steel and furnished with a double gasketed flange and bolted dished door. Equipment up to and including the size of the steam generators can be transferred into and out of the containment through this hatch.

Two personnel locks are provided. One of these is for emergency egress only. Each personnel lock is a double door, welded steel assembly. Quick-acting valves connect the personnel lock with the interior and exterior of the containment

for the purpose of equalizing pressure in the two systems when entering or leaving the containment.

The two doors in each personnel lock are interlocked to ensure that one door is completely closed before the opposite door can be opened. Remote indicating lights and annunciators situated in the control room indicate the door operational status. Provision is made to permit bypassing the door interlocking system to allow doors to be left open during plant cold shutdown. Each door hinge is designed to be capable of independent, three-dimensional adjustment to assist proper seating. An emergency lighting and communication system operating from an external emergency supply is provided in the lock interior.

#### **Special Penetrations – Fuel Transfer Penetration:**

A fuel transfer penetration is provided for fuel movement between the refueling transfer canal in the reactor containment building and the spent fuel pool in the fuel handling building. The penetration consists of a 20-inch (51 cm) stainless steel pipe installed inside a casing pipe. The inner pipe acts as the transfer tube and is fitted with a double gasketed blind flange in the refueling canal and a standard gate valve in the spent fuel pit. The casing pipe is provided with expansion joints and is connected to the containment liner. This arrangement prevents leakage in the event of an accident.

#### **Containment Supply and Exhaust Purge Ducts:**

The ventilation system purge duct is equipped with two tight seating valves to be used for isolation purposes. The valves are remotely operated for containment purging.

## ISOLATION SYSTEM

The Containment Isolation System provides the means of isolating the various fluid systems passing through the containment walls as required to prevent the release of radioactivity to the outside environment.

Design bases of the Containment Isolation System considers several factors. Subsequent to an accident which may release radio-nuclides within the containment, there must be a barrier in all pipes or ducts that penetrate the containment. Leakage from the containment through these pipes or ducts which penetrate the containment is minimized by use of a double barrier. This double barrier ensures that failure of a single active component along a leakage path will not result in loss of ability to isolate the containment.

A barrier may be a valve, a blind flange (two barriers by use of a double gasket), or a closed piping system or vessel. The barriers must be missile protected, Seismic Class 1 and designed for a pressure equal to or greater than the design pressure of the containment. The isolation barriers are located as close to the containment penetration as practicable.

## CONTAINMENT SPRAY SYSTEM

The Containment Spray System (CSS) (Figure 6-4) is an engineered safeguard designed to limit the peak pressure in the reactor containment building to a pressure less than the containment design pressure, in the event of a loss-of-coolant accident or a steam break accident inside the containment. The system also acts to remove airborne fission products, principally iodine, from the containment atmosphere, should they be present due to a fuel cladding break.

## System Description

The CSS achieves the above objectives by spraying a sodium hydroxide solution of borated water throughout a large volume portion of the containment atmosphere. The system consists of a containment spray storage tank (CSST), a spray additive tank (SAT), two pumps, two heat exchangers, and a set of spray ring headers located in the upper dome of the containment and having nozzles designed to provide adequate containment spray coverage. A pump miniflow line, containing a heat exchanger and flow limiting orifice, and a test loop with a throttling valve are connected in parallel across each pump. The test line is open only when testing the pump at various flows. The pumps are normally aligned to take suction from the CSST and the SAT, which drain down together to provide the correct spray pH. Each one of these subsystems is also independently capable of delivering the necessary flow to limit containment pressure in conjunction with the Reactor Containment Fan Cooler System.

## System Operation

**Initial Injection Mode** – Containment spray is initiated automatically in response to a containment high pressure signal. This signal starts the spray pumps, opens the spray header isolation valves "A", and opens the SAT isolation valves "B". Suction is provided to the spray pump from the CSST, with the SAT providing sodium hydroxide solution. The SAT drains into each spray pump's suction header from the CSST; this mixing results in a solution pH that is conducive to the entrainment of iodine (airborne fission product). The spray pumps deliver this solution to the ring headers, and the solution is dispersed throughout the containment atmosphere by the spray nozzles. As this water

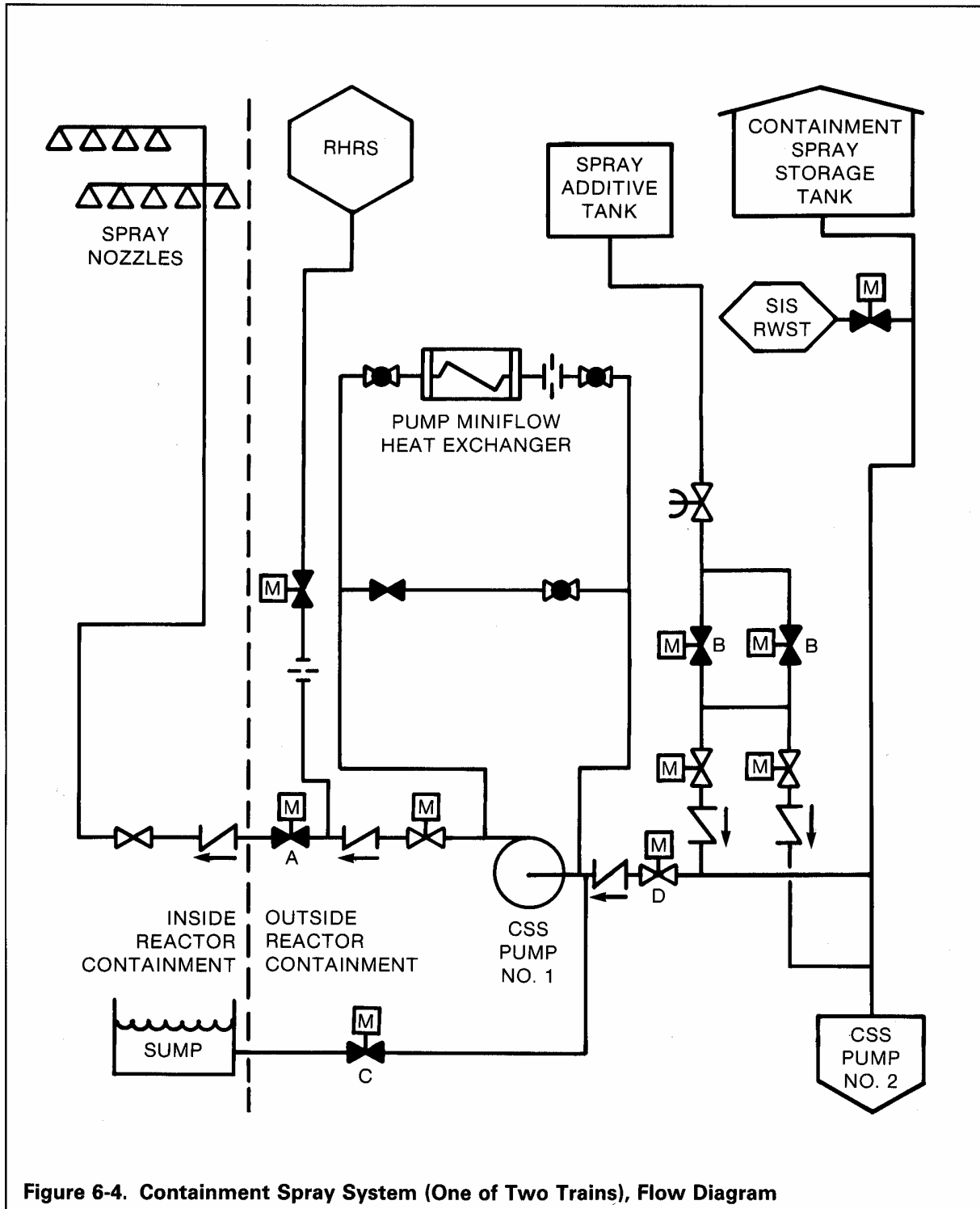

Figure 6-4. Containment Spray System (One of Two Trains), Flow Diagram

comes in contact with the steam in the containment atmosphere, the steam is condensed and falls to the containment floor as drops of a borated sodium hydroxide solution. Also, as the spray is introduced to the containment atmosphere, the solution entrains airborne iodine particles that it contacts; these are then carried to the floor with the spray droplets. The storage tanks are sized to provide approximately 30 minutes of spray with spray additive, and when the CSST is drained to the "Lo-Lo" setpoint, the spray pumps are manually switched to the recirculation mode of spray operation.

An additional function which is performed by the CSS during its normal operation is the pH adjustment of the containment sump. The sodium hydroxide (spray additive) that is delivered through the injection phase is sufficient to raise the long-term sump pH to a level adequate for inhibiting chloride stress corrosion/cracking of stainless steel components, and for keeping the iodine entrained in the water.

**Recirculation Mode** – The recirculation mode of the CSS will be initiated manually by the operator. To accomplish this, the sump isolation valves "C" are opened, and the spray pump suction isolation valves "D" are closed. The pumps will then deliver spray from the sump to the spray headers. Spray additive is not injected during this mode.

## **CONTAINMENT FAN COOLER SYSTEM**

The Reactor Containment Fan Cooler System (RCFC) is designed to remove heat from the containment building during both normal operation and in the event of a loss-of-coolant

accident (LOCA). The RCFC is an engineered safeguard system.

In a containment, the system includes four fan units that operate in parallel. A minimum of two units must function to satisfy design requirements for both normal operation and post-accident operation. Figure 6-5 shows the elements of one RCFC unit.

During normal operation, air is drawn from the upper part of the containment, through the return air ductwork, and continues through the normal flow inlet damper into the roughing filter plenum. The air continues its flow through the cooling coils and discharged by the fan into the ventilation system distribution ductwork.

During the post LOCA operating mode, the air flow is routed from the return air ductwork, through the emergency flow inlet damper, and into the filtration package plenum. Here the air flows through moisture separators, HEPA filters, and discharges through the emergency flow outlet dampers into the roughing filter plenum and then into the cooling coils. When a LOCA is sensed, the fan motors are automatically switched to low speed to provide proper flow of the steam-air mixture.

A gravity actuated backdraft damper is installed in the ventilation system discharge ductwork of each fan. These dampers serve to isolate units from the ventilation system when the fan is not in use and to protect each unit from damage due to reverse flow during a LOCA pressure transient.

The cooling coils remove heat from the air with the fan providing the required air flow rates. Cooling water is supplied by the essential service water system. Drain troughs and piping

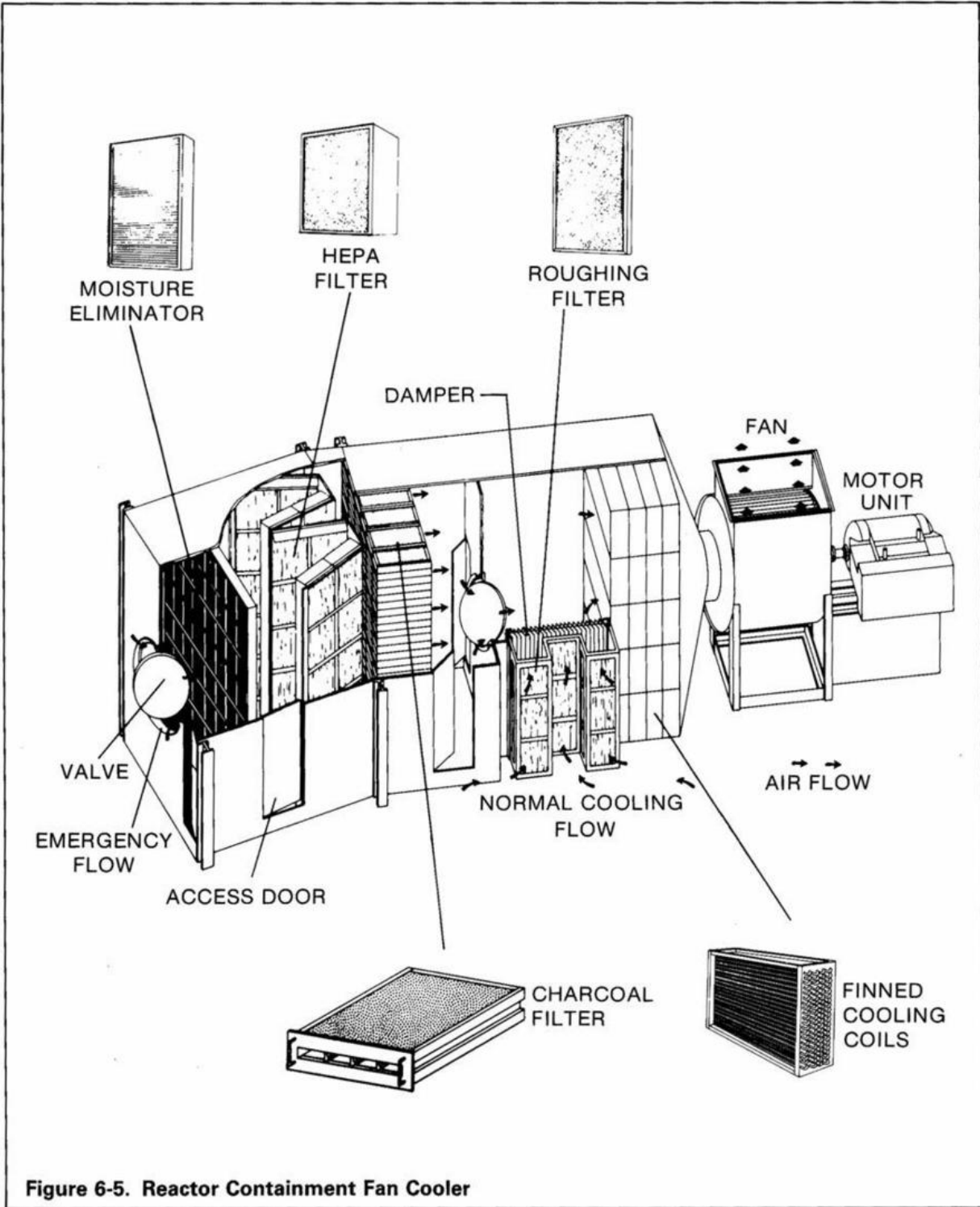



are provided to remove condensate humidity from the cooling coils. The drain piping is routed to the containment sump.

## **HYDROGEN DETECTION AND SUPPRESSION SYSTEM**

Under accident conditions, coolant radioactivity and the Zirconium water reaction can result in the release of hydrogen gas to the containment atmosphere. Eventually the gas could accumulate to an explosive hydrogen/oxygen concentration. To control this potential risk the reactor containment is provided with:

- A hydrogen detection system that can detect and report in a continuous manner the hydrogen content in the containment atmosphere. Alarms at proper setpoints are provided.
- A containment ventilation system that circulates the containment atmosphere to remove pockets of high hydrogen concentration after an accident.
- Hydrogen recombiners that burn the free hydrogen. The hydrogen/oxygen combination results in water.

# **chapter 7**

# **instrumentation and**

# **control**

The Instrumentation and Control Systems can be viewed as the "central nervous system" of the plant and consist of the following major systems:

- **Nuclear Instrumentation System**  
Provides continuous indications of the reactor core power level from shutdown to full power.
- **In-core Instrumentation Systems**  
Senses the distribution of the nuclear flux within the core.
- **Digital Rod Position Indication System**  
Detects the position of the control rods in the reactor core.
- **Process Instrumentation System**  
Senses the state of the plant, when used together with the Nuclear Instrumentation, In-Core Instrumentation, and Digital Rod Position Indication System.
- **Nuclear Steam Supply Control Systems**  
Implements the operator's control decisions and automatically changes the plant to and maintains it at selected operating states.
- **Reactor Protection System**  
Protects the reactor core and the nuclear steam supply system by monitoring operating parameters and initiating safeguards actions on the detection of abnormal conditions.
- **The Control Room**  
Provides information to the operator to enable him to comprehend the plant's state

and to make and implement operating decisions.

- **Plant Computer System**

Provides computational, data processing, and data presentation services for the plant.

## NUCLEAR MEASUREMENTS

The nuclear excore instrumentation, in-core instrumentation, and  $N^{16}$  power monitoring instrumentation systems sense the intensity and distribution of the nuclear reactions in the reactor core for use by the remainder of the Instrumentation and Control systems. The state of nuclear reactions can be described as the power level produced by the nuclear reactions and its distribution throughout the core.

### Nuclear Instrumentation System

The nuclear excore instrumentation system senses the reactor core's status by monitoring the neutron flux during startup and power operation. The information from this system plays a key part in the reactor protection function.

The nuclear instrumentation monitors the reactor power from the Source Range and Intermediate Range where heat production is negligible through the Power Range for up to 120 percent of full power output, by means of thermal neutron flux excore detectors located in instrument wells in the primary shield adjacent to the reactor vessel. The system provides indication, control, and alarm signals for reactor operation and protection as follows:

**Detectors** – The system employs 8 detector locations containing a total of 24 detectors. Four of these detectors are proportional counters

used in the source range channels, located in vertical instrument wells adjacent to four "flat" sides of the core, at an elevation approximating one-quarter of the core height.

Each of the source range detector locations also contains a compensated ion chamber which is used for intermediate range channels, at an elevation corresponding to one-half of the core height.

At the other four detector locations are four-section ionization chambers. One four-section ionization chamber assembly is located in each instrument well adjacent to each "corner" of the core cross section. The range of operation for the detectors with the designed range overlaps is shown in Figure 7-1.

**Source Range** – The four source range channels use proportional counters. Neutron flux, as measured in the primary shield area, produces current pulses in the detectors. These pulses are amplified by solid state preamplifiers and are then transmitted to solid state amplifiers and discriminators.

These channels provide information on the flux level for reactor trip protection, and alarm signals to the reactor control and protection systems when the flux is in the source range. They are also used at shutdown and refueling to provide a reactor containment alarm for any inadvertent increase in reactivity. An audible count rate signal is provided during initial phases of startup in the containment and the control room. Startup rate indication is also provided in the control room.

**Intermediate Range** – Four intermediate range channels utilize four compensated ionization

chambers. Detection chamber current from the ion chamber is transmitted to solid state logarithmic amplifiers.

These channels indicate the intermediate flux level and also provide high neutron flux alarm signals and trip signals. The channels also provide a permissive signal to allow manual initiation of a source range level trip bypass block, and removal of the high voltage from the source range detectors when the flux level is in the intermediate range. The permissive signal automatically reactivates the source range channels on decreasing flux level. Startup rate indication is provided in the control room.

**Power Range** – Four channel sets of power range measurements are provided, one for each protection channel set. Each utilizes four individual uncompensated ionization chamber currents.

The four-section detector current signals from each detector provide axial power distribution information, which is displayed on the main control board and used as an input to the low Departure from Nuclear Boiling Ratio (DNBR) and high kw/ft protection trips. These channels also provide permissive signals to allow manual initiation of intermediate range and power range (low setpoint) reactor trip bypass (block), and automatic reset on decreasing power level.

## In-Core Instrumentation

In-core instrumentation (Figure 7-2) provides information on the neutron flux distribution and fuel assembly outlet temperatures at selected core locations. The in-core instrumentation consist of top or bottom mounted thermocouples and bottom mounted movable miniature neutron

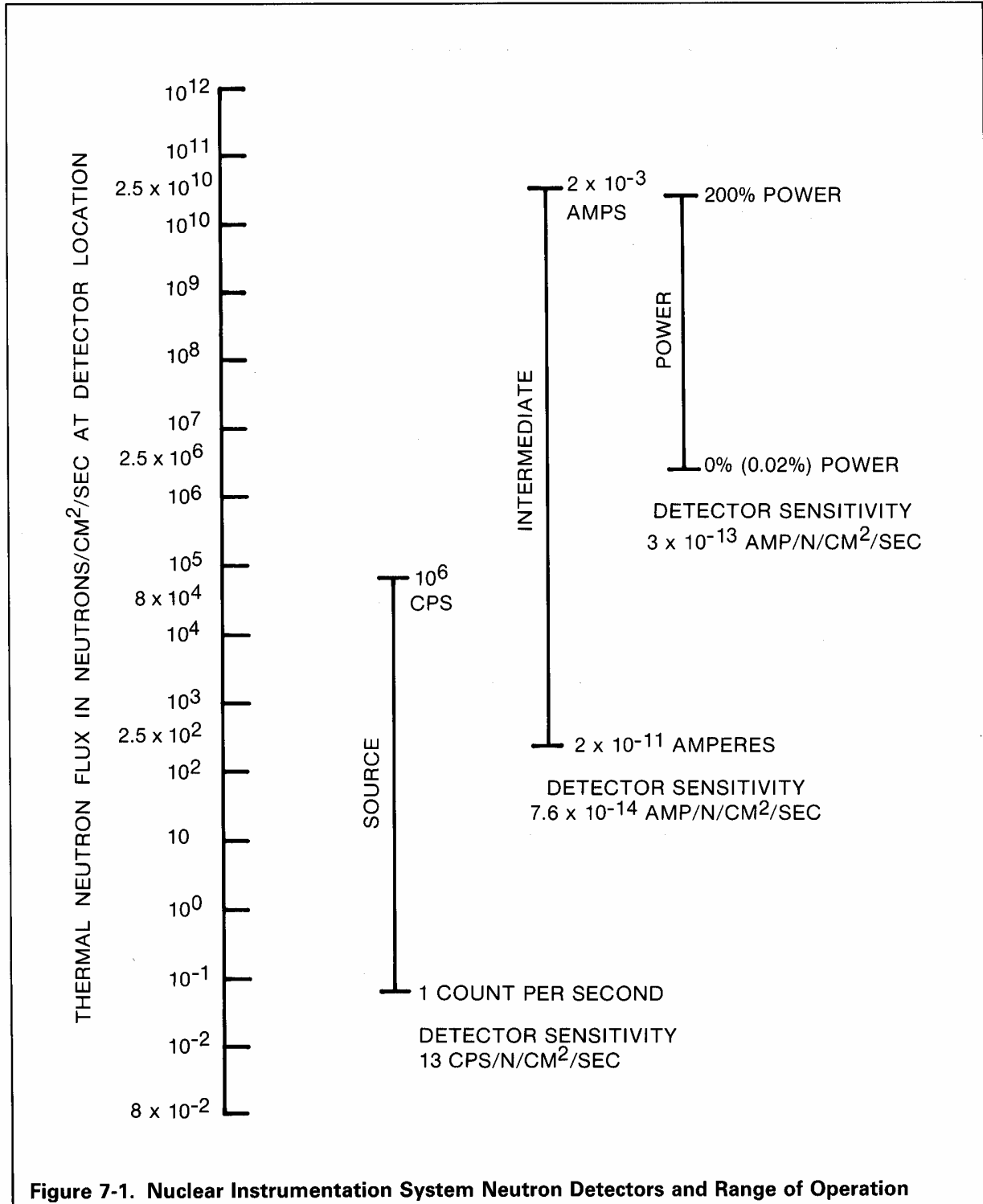
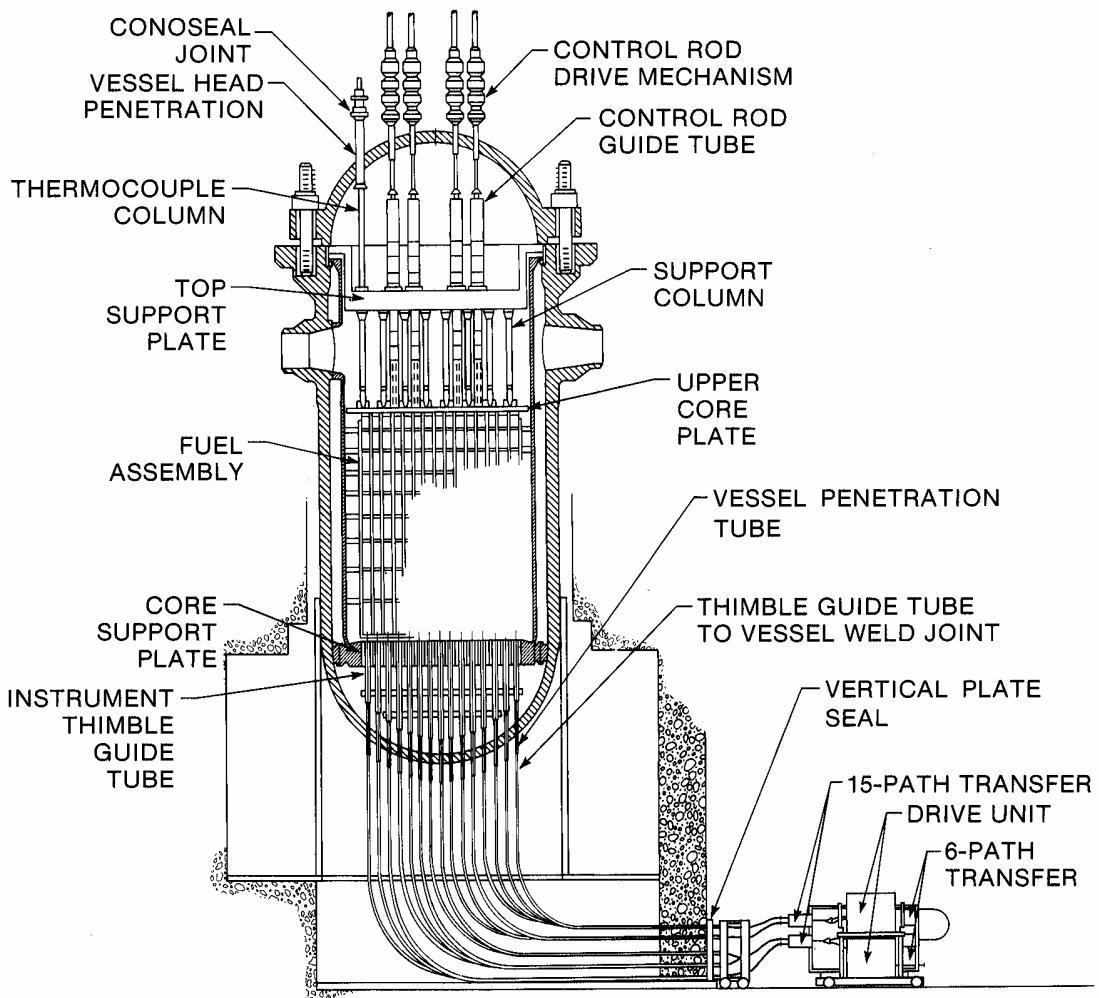

Figure 7-1. Nuclear Instrumentation System Neutron Detectors and Range of Operation



**Figure 7-2. Typical In-Core Instrumentation System**

detectors. The thermocouples are positioned at preselected locations to measure fuel assembly coolant outlet temperature for use in monitoring the core radial power sharing and coolant enthalpy distribution. The movable flux detectors can traverse the entire length of selected fuel assemblies to provide an extremely accurate, three-dimensional map of the neutron flux distribution. This data can be used to determine the power distribution in the core at any time during the fuel cycle, to check the calibration and response of the flux detectors external to the reactor vessel, and to determine linear power density, burnup, and fuel inventories. The data will also provide trends of core conditions so that corrective action can be taken before a condition becomes excessive.

**Digital Flux Mapping System** – The Flux Mapping System is composed of three major groups of equipment: a flux mapping console, a detector drive train and a flux thimble system.

The flux mapping console is separated into two essentially identical redundant sections, each capable of automatically controlling the detector drive train and collecting, analyzing, recording, and transmitting data. The data gathered from the detectors are reported to an associated CRT, printer, floppy disc, and the plant process computer. Full-core flux maps may be obtained even if a section of the console, parts of the drive system, or some detectors are out of service.

The flux mapping console provides the operator's interface and contains the movable detector system's controlling electronics. Operator commands are supplied in a conversational manner through monochromatic, graphic CRTs having keyboards.

The Flux Mapping System performs a fully automatic preprogrammed, operator-programmed, or manually controlled flux mapping of the reactor core. The operator can control and check data limits, set the detector voltage, and determine the disposition of the flux mapping data.

The detector drive train provides the mechanical means of routing the four movable detectors into various thimbles and into and out of the reactor core. The function of the detector drive train is to 1) drive a miniature detector to a location within the reactor core, 2) move the detector through the core for scanning and recording of detector output, and 3) withdraw the detector.

The detector drive train (Figure 7-3) consists primarily of drive assemblies, controller units (each of which controls two drive assemblies), switch assemblies, 6-path transfer assemblies, 15-path transfer assemblies, wye assemblies, a manual control box and a portable controller. All elements of the detector drive train, except the manual control box and the portable controller, are mounted on a movable frame assembly which can be easily relocated for refueling operations and then restored to its operating position.

The four drive assemblies are labeled A, B, C, and D. Each drive assembly is connected via a corresponding 6-path transfer assembly, a wye assembly, and 15-path transfer assembly to the thimbles. In normal operation, drive assembly A is connected to 6-path transfer A, from there to 15-path transfer A, and continues with similar routings for the others. When required, the detector cable from drive A can be routed through either of 15-path transfer assemblies B, C or D, etc. The other two paths of the 6-path transfer assemblies are connected through a



common wye assembly to a separate calibration thimble and to a shielded area for storage of the radiated detector, respectively.

Retractable thimbles of cold-worked stainless steel are pushed into the reactor core through thimble guide tubes, which extend from the bottom of the reactor vessel down through the

concrete shield area, then to a thimble seal plate. The minimum bend radii are 8 feet (2.4m). The trailing ends of the thimbles (at the seal plate) are extracted during refueling of the reactor to avoid interference with the core.

One thimble guide tube is provided for each retractable thimble. Each guide tube is approximately 1 inch in outside diameter and extends through the primary shield. It terminates at, and is welded to, the vessel penetration tube and guides the thimble between the seal plate and reactor vessel.

Retractable thimbles, when fully inserted, extend from the seal plate, through the guide tubes, and up into specified fuel assemblies. The retractable thimbles, closed at the leading edge, are dry inside, and serve as the pressure barrier between the reactor coolant and atmosphere.

Because the retractable thimbles are pressure-sealed to their guide tubes, they will be inserted or removed only during periods of plant depressurization. Before initial insertion of the retractable thimbles, the thimble guide tubes are sealed by thimble seal plugs to permit hydro-testing; the retractable thimbles are not inserted for this testing because the fuel is not in the reactor core to support the thimbles.

The retractable thimbles are pressure-sealed to their guide tubes and are stationary during normal operation, being moved only during refueling or for maintenance, at which times a space beyond the seal plate must be cleared for the retraction operation.

**Thermocouples** – The fuel assembly outlet temperature is measured with thermocouples using Chromel-Alumel hot junctions clad with

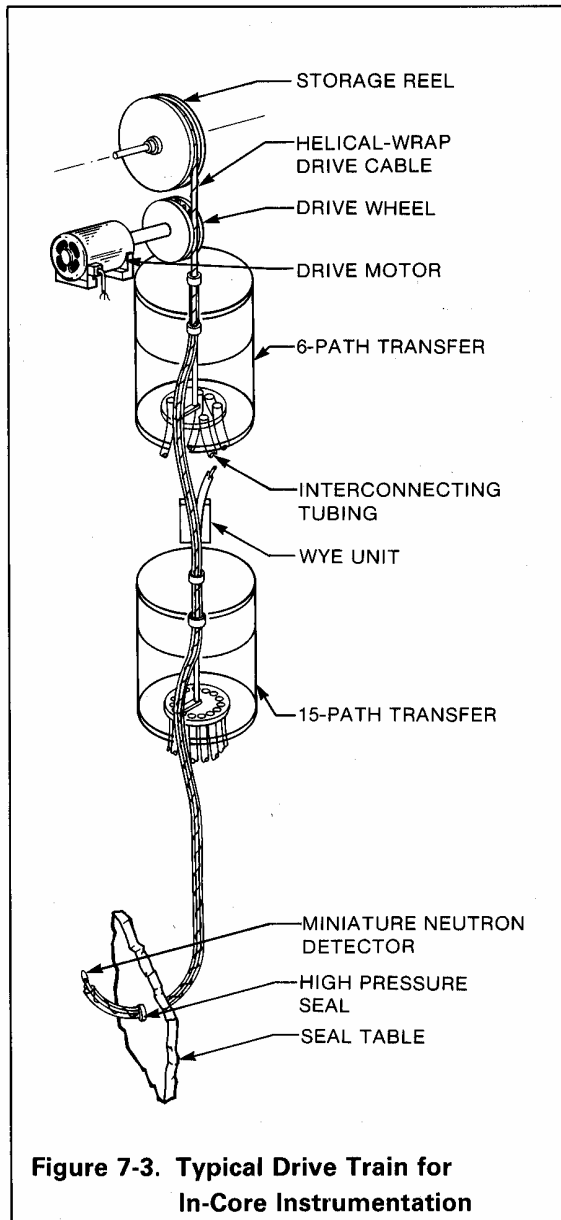

**Figure 7-3. Typical Drive Train for In-Core Instrumentation**

stainless steel. These thermocouples enter the reactor vessel through the vessel head ports on the reactor vessel head and extend to a position above the upper core plate of the vessel internals. Thermocouple conduits are permanently attached to the upper internals to guide the thermocouples into the vessel.

Thermocouples are inserted in the conduit by means of a specifically designed tool which provides the axial force necessary to seat the swaged end of the thermocouple hot junction into a conical seat at the conduit terminus inside the vessel. The thermocouple terminates in a disconnect plug outside the vessel and above the conduit. With the thermocouples fully inserted, a swage-type fitting provides a seal between the thermocouples and the end of the conduit.

An alternate thermocouple placement mounts the in-core thermocouple at the end of double walled flux thimbles. The thermocouple wires are routed between the walls, which requires the use of a thinner movable detector. The alternate method eliminates some hardware in the head and upper internals, reduces worker radiation exposure during the refueling operation, and simplifies the replacement of failed thermocouples.

### **N<sup>16</sup> Power Monitoring Instrumentation**

This instrumentation monitors the thermal power of the NSSS by detecting the level of N<sup>16</sup> present in the coolant system. (N<sup>16</sup> is an isotope of nitrogen generated by neutron activation of oxygen contained in the water.) The level of N<sup>16</sup> present in the primary coolant is directly proportional to the fission rate in the core. Decay of the N<sup>16</sup> isotope produces high energy gamma rays which penetrate the wall of the high-

pressure piping and are therefore available for use in measuring the N<sup>16</sup> concentration in the primary coolant.

N<sup>16</sup> gamma radiation is monitored by ion chambers located on the hot leg piping of each coolant loop. The ion chambers are located as close as physically possible to the reactor vessel but outside of the biological shield.

The N<sup>16</sup> monitoring hardware can also be employed as part of the Transit Time Flowmeter (TTFM) which accurately measures reactor coolant flow.

The TTFM accurately measures the reactor's coolant's flow rate for the primary loop by sensing the radioactive signature of the N<sup>16</sup> isotope with gamma detectors. Cross-correlation techniques are used to determine the mean transit time of the N16 signature. If the distance between the detectors, the measured transient time, and the piping internal diameter are known, the volumetric flow rate in each coolant loop can be determined. This direct conversion of N16 activity to RCS flow rate is accomplished with an accuracy of ± 1.5 percent which can result in improved safety margins in safety analyses.

### **DIGITAL ROD POSITION INDICATION SYSTEM**

The Digital Rod Position Indication System (DRPI) derives the position of the control rods in the reactor core (Figures 7-4 and 7-5) by two methods.

In the first method, the DRPI measures the actual position of each rod using a stable and proven digital technique. Each detector consists of 42 discrete coils mounted concentrically with

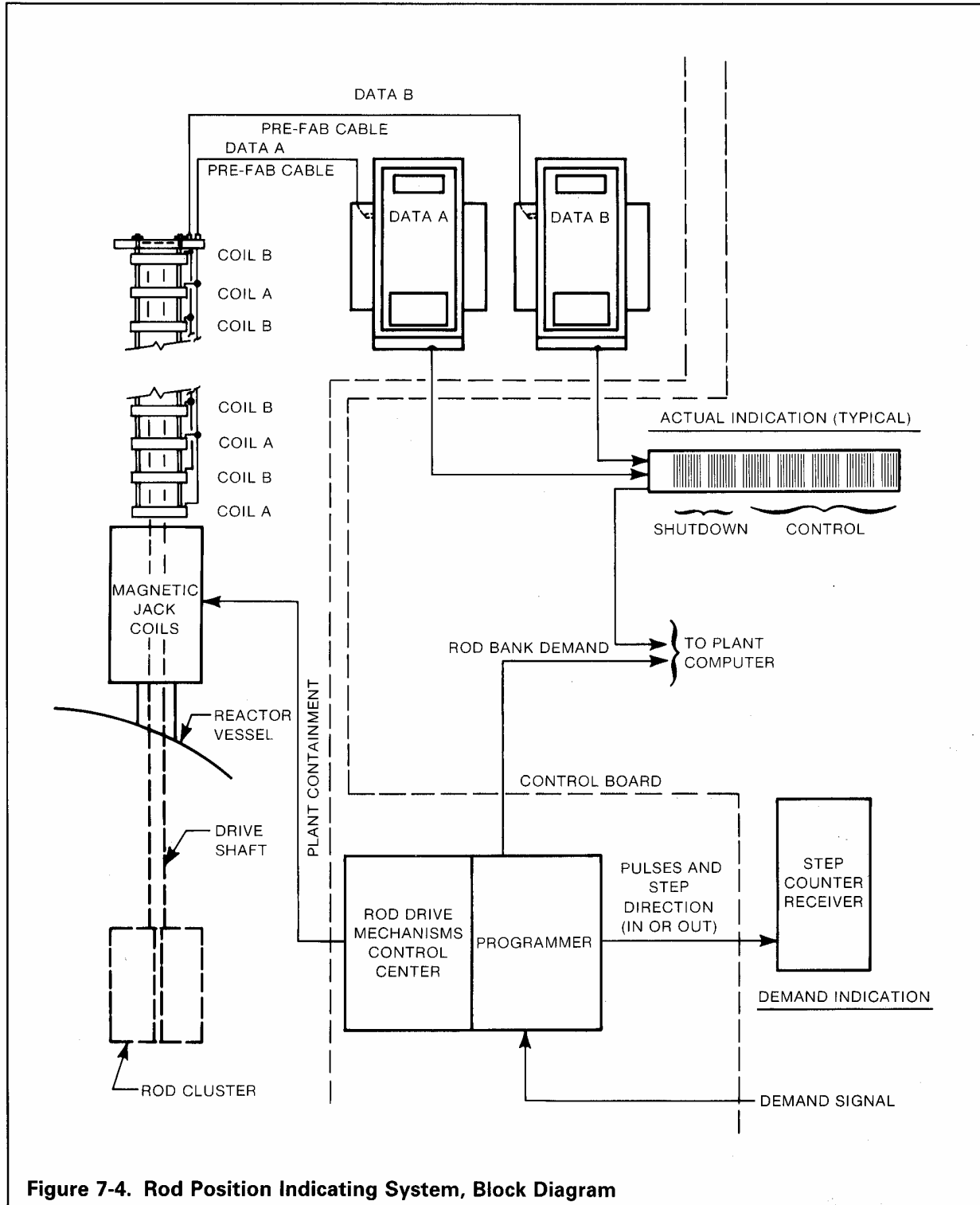

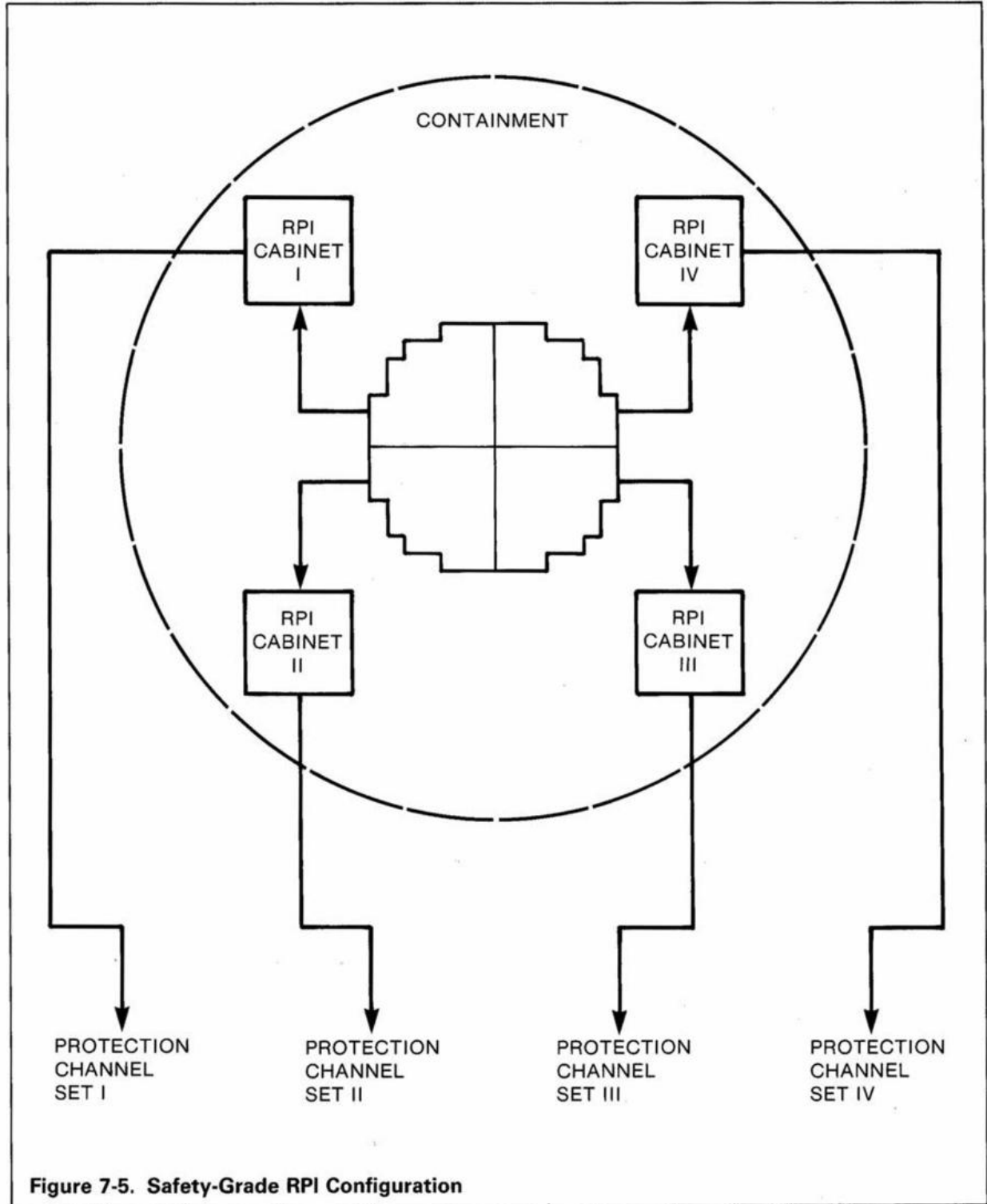

Figure 7-5. Safety-Grade RPI Configuration

the rod drive pressure housing. There is a 3.75-inch (95 mm) (6-step) axial spacing between coil centerlines. Each detector magnetically senses the entry and presence of the rod drive shaft through its centerline. The coils are interlaced into two data channels (data A and B) to provide system fault tolerance through redundancy. Employing two separate channels of information (coils, wiring, and electronics) allows the digital rod position indication instrumentation to continue functioning (with reduced resolution) when one channel fails.

The core is divided into quarters; each quarter is assigned to a protection channel to provide efficient physical separation of protection grade field wiring in the head area. One field cabinet contains the electronics for processing the A data and B data for each protection channel.

The data from each field cabinet is multiplexed over redundant data links (twisted single pairs) to the Integrated Protection System (IPS) to provide safety-grade rod position data to the DNBR and kw/ft calculators. A separate data link with safety-grade isolation is provided from each in-containment cabinet to a dedicated non protection-grade CRT display and provides the operator with a graphic display of actual rod position.

The second method of indicating rod position involves counting the number of steps demanded to move the rods up or down, as generated by the rod control system. This information is also displayed on the control board.

## PROCESS INSTRUMENTATION

Process instrumentation is provided for the various primary plant and related systems to measure temperature, pressure, fluid flow, fluid

level as in tanks or vessels, and occasionally, physiochemical parameters such as fluid conductivity or chemical concentration. The term "process instrumentation" specifically excludes neutron, gamma, and radiation measurements. Process instrumentation includes the process-measuring sensors, power supplies, indicators, signal conditioning devices, and so forth, which are necessary for monitoring the operation of the Nuclear Steam Supply System.

## NUCLEAR STEAM SUPPLY CONTROL SYSTEM

The basic function of a power plant is to supply electrical energy to the power distribution network on demand. To meet this demand (load), the nuclear core must provide heat generation proportional to the demand (electrical power output) and the NSSS must respond with the correct flow of low-moisture steam to the turbine-generator. This is normally accomplished automatically by the coordinated action of a number of subsystems. These subsystems also provide for the control of rapid disturbances arising from abnormal conditions and for control of processes that maintain the plant in an economical operating condition.

The nuclear steam supply control system has two principal objectives: 1) to control reactor temperature so that the steam output matches the turbine-generator requirements, and 2) to operate the NSSS safely and reliably.

The major subsystems of the NSSS control system (Figure 7-6) are as follows:

- Power Control System
- Reactor Pressurizer Control System

- Steam Bypass Control System
- Feedwater (steam generator level control) Control System

The process control systems require pressure, flow, temperature, and level parameters from the Boron Thermal Regeneration System, Chemical and Volume Control System, Reactor Coolant System, Residual Heat Removal System, and Safety Injection System. These control systems automatically perform many functions to support the performance and operation of the primary loop such as maintaining water inventory, concentration, and charging flow.

The subsystems shown in Figure 7-6 are designed to act independently of one another. However, there is strong coupling through the controlled parameters, which leads to a unified response to plant load transients.

The flexibility and degree of integration that are reasonable in a control system are a function of the characteristics of the controlled system, the characteristics of the hardware used to implement the control, and the design basis of the system. The NSSS control systems used before the late 1970s were implemented by using analog computer type hardware which provided accurate, reliable control. With this system it was reasonable to supply some of the flexibility and some of the integration by relying upon the operator's capabilities and the natural strong coupling of the controlled system.

Later control systems are implemented with microcomputer networks (Integrated Control System or ICS). The microcomputers (digital technology) permit more flexibility, more accurate and complex control calculations, more complete information feedback to the operator,

and a higher degree of control system integration. In addition, automatic load dispatching becomes a factor in the design basis.

## Power Control System

The Power Control System (Figure 7-7) automatically adjusts the reactor power and power distribution through control rod motions, boron concentration changes, and control of the moderator temperature. Several interdependent subsystems allow the reactor to automatically follow load and be controlled with only minimum operator interface. Load follow operations are explained in Chapter 16, Plant Operation. The subsystems of the Power Control System are as follows:

- Rod control system
- Power distribution control system
- Boron control system
- Remote dispatch system interface

**Rod Control System** – The rod control system automatically adjusts the power level of the reactor to match the power demanded by the turbine. The needed control rod movement is based on the reactor coolant temperature needed to meet the turbine power demand, the nuclear power (neutron flux level) rate of change, and the measured reactor coolant temperature.

The rod control system also has an expandable temperature error control deadband for use at reduced power levels, which allows the reactor coolant temperature to vary between wider bounds. This will permit the temperature changes (through the negative moderator coefficient) to initiate changes in reactor power

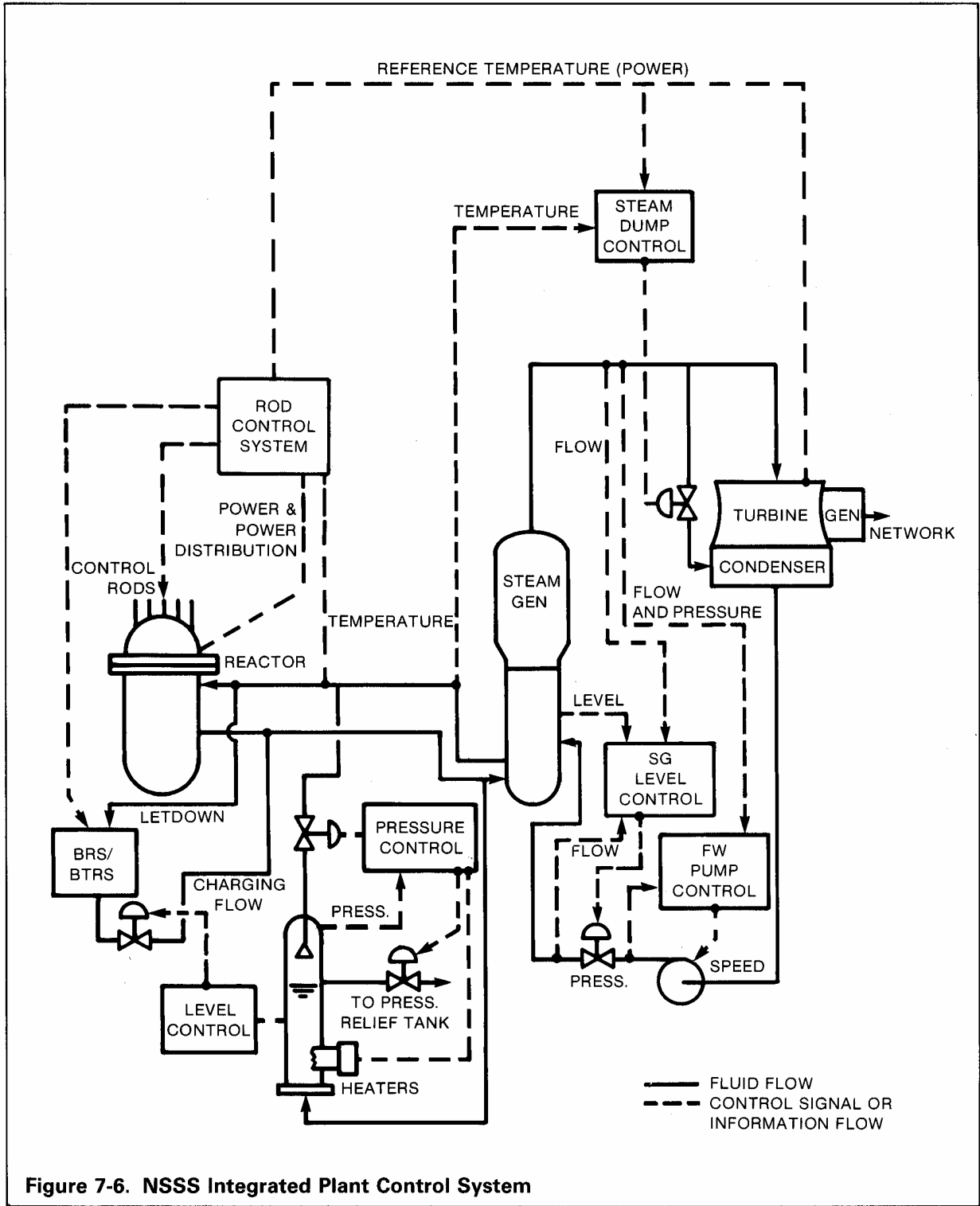

Figure 7-6. NSSS Integrated Plant Control System



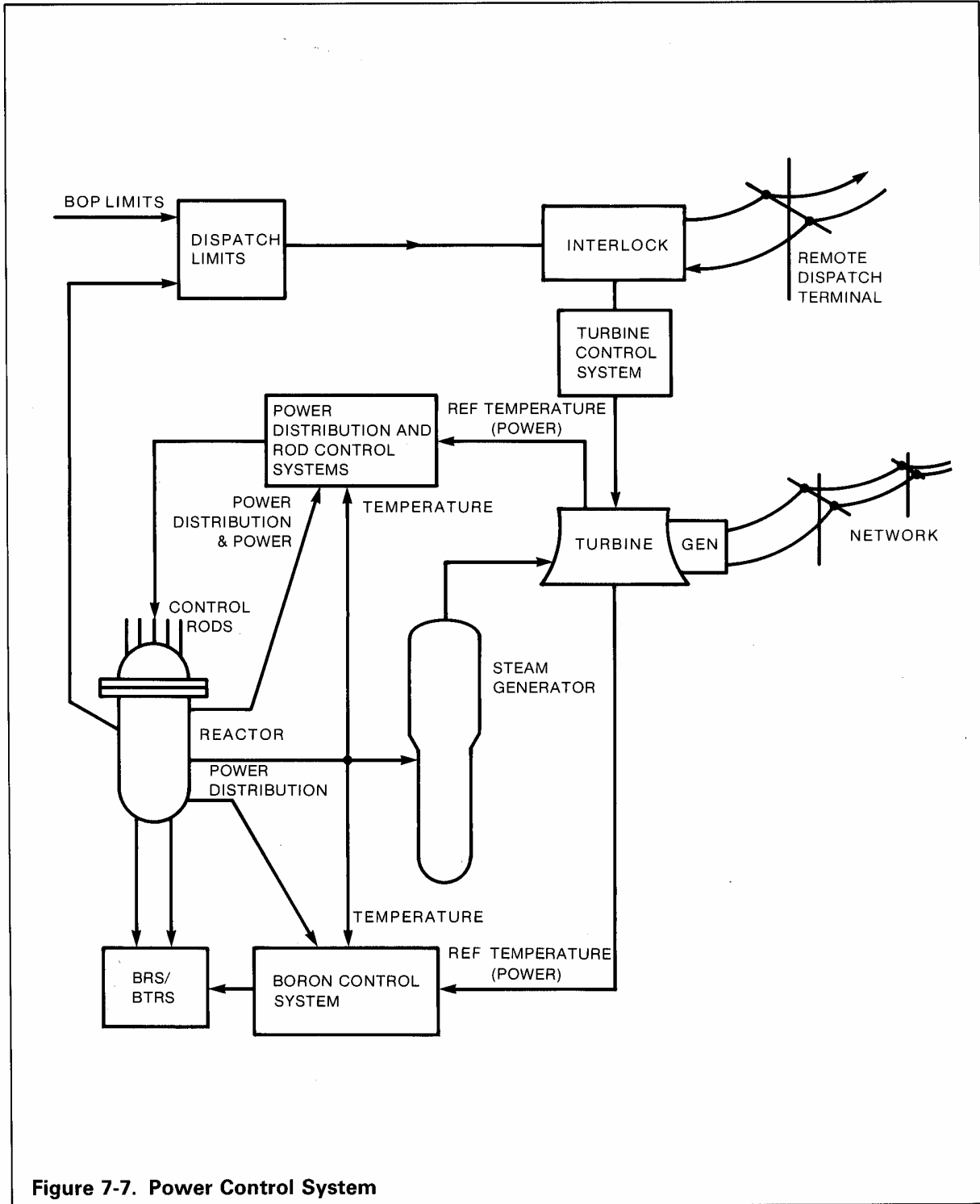

Figure 7-7. Power Control System

as required to regulate electrical network load frequency transients (by random load variations of  $\pm 5$  percent power). This minimizes rod movement and wear and reduces the disturbance to the axial power distribution.

There are two types of rod groups: control and shutdown. The control groups are used in conjunction with chemical shim and temperature change to provide reactor power control. The shutdown groups along with the control groups are used to safely shut down the reactor.

The rod control system has three basic modules external to the Integrated Control System cabinets:

- The logic cabinet which receives various demand signals, either manual from the operator or automatic from the reactor rod control system, and provides the command signals needed to operate the shutdown and control rod groups in a pre-arranged program.
- The power cabinet which provides the programmed dc currents to the operating coils of the rod control drive mechanisms.
- A dc holding supply cabinet which provides auxiliary power to the mechanisms to facilitate keeping the mechanism in its last controlled operating position.

The rod control system has provisions for manual operation of the shutdown rods. The shutdown rods are withdrawn first during startup and are kept fully withdrawn during power operation. The control groups are withdrawn in a programmed sequence only after the shutdown groups are fully withdrawn.

The rod control system also provides for manual as well as automatic operation of the control groups. In both the automatic and manual modes, the control groups are moved according to a preset program. The sequencing provided by this program is reversible, that is, the withdrawal sequence is the reverse of the insertion sequence. In the manual mode, the rate of insertion or withdrawal is adjustable but preset at a fixed value. In the automatic mode the rod speed is variable and determined by the control system algorithms.

Eight trip breakers are placed in a series/parallel connection with the power supply of the rod control drive system. The trip breakers are actuated by the reactor protection system.

**Power Distribution Control System** – The power distribution in a reactor core is not uniform. Peak power can more than double the average power. Consequently, the power output of the reactor is limited by the power peaks in the axial and radial core planes, because they subject the fuel to the most severe duty. Hence, the control of power peaks is an important part of overall reactor control.

Radial power peaks are a function of core burnup, core loading, and control rod design and layout. These factors are carefully accounted for in the core design to minimize radial peaking factors. The operator does not have these variables under his control during plant maneuvers.

The axial power peaks in the core are affected by:

- Control rod insertion
- Axial xenon distribution

- Core burnup
- Top-to-bottom moderator density changes within the core

Of these, only xenon distribution and control rod insertions are under the direct short-term control of an operator.

The power distribution control system provides automation of the Constant Axial Offset Control (CAOC) strategy. The CAOC strategy maximizes the margins between any given normal operational condition and the limits established by the NRC criteria for emergency core cooling system evaluation of the loss-of-coolant accident. Axial offset (A.O.)\* is used as the control variable and is obtained from NIS measure-

ments made for the protection system. The control error is the difference between the measured A.O. and permitted A.O. (setpoint), which is a function of core power.

The normal mode of operation involves keeping the A.O. within the target band (Figure 7-8). However, operation outside the target band is permitted to improve the transient capabilities of the plant. The duration of such operation is automatically limited to prevent subsequent problems with xenon redistribution. The margins to plant trip calculated by the protective system determine the maximum limits of the axial offset.

$$* \text{ A.O.} = \frac{\text{Power at top of core} - \text{Power in bottom of core}}{\text{Total power}}$$

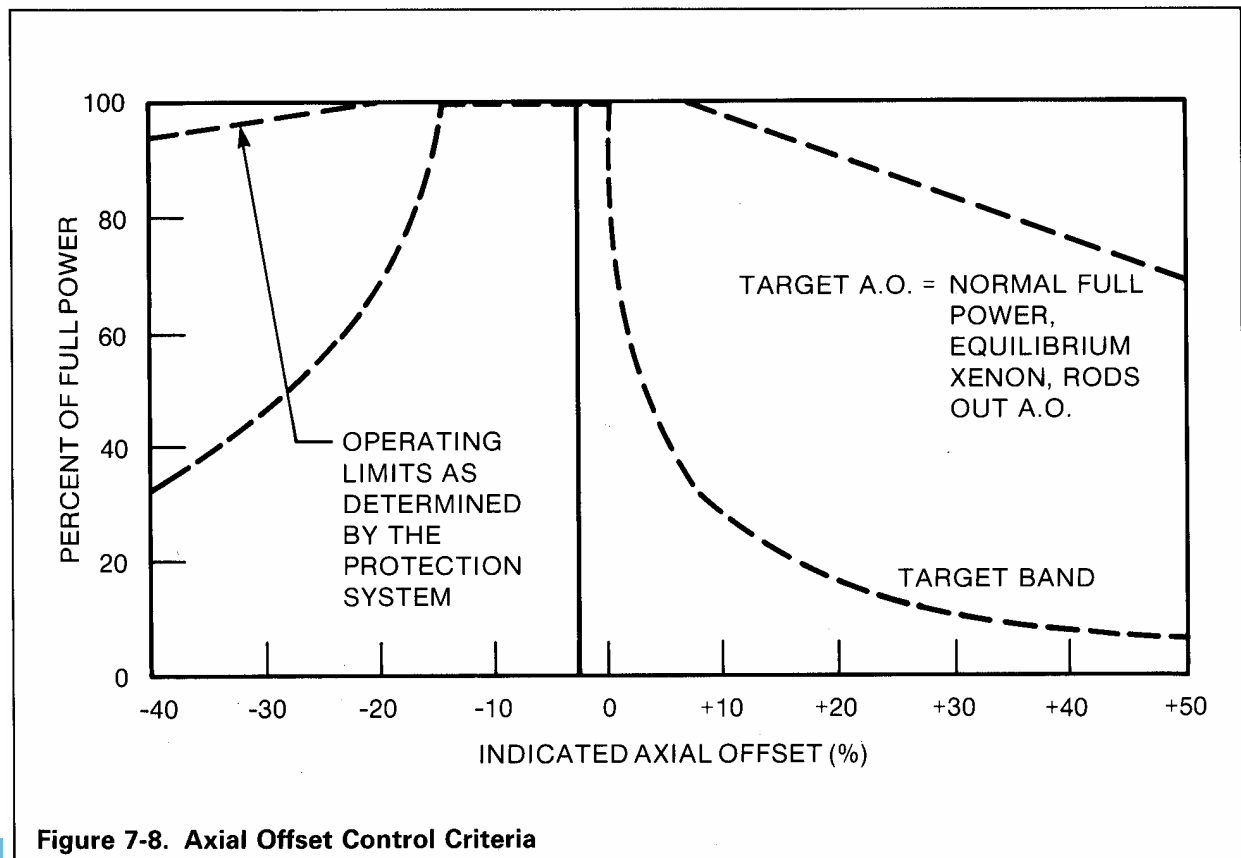

Figure 7-8. Axial Offset Control Criteria

The A.O. error actuates the boron control system. Changing the boron concentration in the reactor coolant will change the coolant temperature which in turn will cause the control rods to move, thereby adjusting the A.O.

Two other modes of A.O. control, which do not operate freely in the entire target band as described above, are also available. The first will keep the A.O. in a narrow band about the target value, for closer control of the power distribution and minimized boron use. The second operating mode keeps the A.O. near the edges of the target band to maximize spinning reserve capabilities. The operator controls the bandwidth.

**Boron Control System** – The boron control system interacts with and integrates the other components of the power control system. Control of the reactor coolant's boron concentration involves both the Boron Thermal Regeneration System (BTRS) and the Reactor Water Makeup System. Control activities are directed toward the BTRS; the makeup system automatically comes in when necessary.

The operating mode (boration or dilution) and the magnitude of the boron concentration change required is determined by comparison of the measured  $T_c$  (cold leg temperature) with the programmed (function of power)  $T_c$  combined with the A.O. mismatch. If this total error is large enough, the BTRS is switched to the proper mode (this can also be done manually in anticipation) and the amount of coolant modulated through the resin beds will be proportional to the magnitude of the mismatch.

The boron control system also automatically compensates for changes in the xenon level that occur during load maneuvers and compensates for the  $T_c$  error whenever control rod operation is restricted for any reason.

**Remote Dispatch Interface System** – The primary purpose of the remote dispatch interface system is to supply a remote network-dispatching computer all the information it needs to include the plant as a part of its plant-loading algorithms, and to act as a permissive network so that unsafe demands from the computer cannot be executed.

The power capabilities of the NSSS are calculated based on current operating conditions and power distribution limits. These can be moderated (lessened) by operator-established limits or by balance-of-plant (BOP) equipment constraints. If operator dispatching permission has been granted and no safety limits are being approached, the power capabilities will be transmitted to the dispatch system.

The dispatch system decides how much power change (if any) to request from the plant and transmits the request back to the plant. If operator dispatching permission has been granted and no safety limits are being approached, the remote unit will act through the turbine control system to change the turbine throttle valves. This cycle is repeated every few seconds. The requests sent out by the dispatch system each time are normally a very small part of the plant's change capability. Any change in the NSSS or BOP will be immediately factored into the site calculations and will be transmitted to the dispatch system.

The output to the dispatch system is also sent to the operator, who can withdraw his permission and block further remote dispatching. Any such action will be automatically announced to the dispatch system which will still be capable of interrogating and analyzing the current operating status of the plant.

## Reactor Pressurizer Control System

The reactor pressurizer control system has two functions. First, it must keep the pressure of the Reactor Coolant System (RCS) within the desired limits, through control of the pressurizer heaters, spray valves, and relief valves. Second, it must maintain the RCS mass inventory, that is, the pressurizer level, by balancing the charging flow to the letdown flow.

## Steam Bypass (Steam Dump) Control System

For a large step load decrease or a reactor trip the steam bypass control system removes sensible heat stored in the RCS. The programmed full load average reactor coolant temperature corresponds to a saturation pressure that is higher than the steam generator safety valve set pressure. For a large step load decrease or a reactor trip, steam is dumped to the condenser (or atmosphere as required) to remove the stored heat in the primary system at a rate fast enough to prevent lifting of the steam generator safety valves.

When a load rejection occurs, if the difference between the required temperature setpoint of the RCS and the actual average temperature exceeds a predetermined amount, a signal will actuate the steam dump to maintain the RCS temperature within control range until a new equilibrium condition is needed. The steam dump flow reduces proportionally as the control rods act to reduce the average coolant temperature. The steam dump is interlocked with plant output to enhance overall control response.

## Feedwater Control System

Automatic feedwater control is provided to cover the full load range from zero to full power by means of two automatic control systems: one covers the load range from 15 to 100 percent of rated power, and the other provides control from zero to 20 percent of rated power. Transfer from one system to the other (during power escalation, for instance) would occur during a power level for which there is overlap between the two systems, that is, between 15 and 20 percent of rated power.

**Feedwater Control from 15 to 100 Percent Power** – A three-element feedwater control system governs individually the water level of each steam generator above 15 percent power through means of individual feedwater regulating valves. The control system uses the measured process variables of steam generator level, feedwater flow, and steam flow. When the steam generator level is equal to the setpoint, which is a function of power, the control system will maintain feedwater flow equal to steam flow.

On a load change, steam flow and steam generator level tend to change simultaneously. In so doing, they momentarily indicate opposing corrective control action. For example, on a load pick-up, the steam generator level encounters initially a "swelling" effect which calls for a decrease in feedwater flow. At the same time, the increase in steam flow develops a higher flow than the feedwater flow which calls for an increase in feedwater flow. The opposite corrective indications occur on a load drop brought about by the "shrinking" effect in the steam generator and the decrease in steam flow.

The feedwater control system is similar to that in the conventional (fossil) thermal plant with the possible following exceptions:

- A main feedwater control valve is required for each steam generator to ensure that the correct flow and water inventory is provided.
- Condenser hotwell water storage capacity must be provided to accommodate system surges due to turbine load reductions and the amount of steam bypass required without relying upon the reserve condensate storage.
- Storage is required for operational purposes such as feedwater makeup, when the water treatment plant is being regenerated or out of service. Also, the storage will facilitate plant cooldown on blackout conditions when the emergency feedwater system is placed in service.

#### **Feedwater Control Below 20 Percent Power –**

A feed forward control system controls the water level of each steam generator individually below 20 percent power. Instrumentation includes steam generator water level, turbine impulse stage pressure, and nuclear power. When the steam generator level equals the reference level, which is determined by the turbine impulse first stage pressure, the control system will maintain a feedwater flow proportional to nuclear power.

The control system, utilizing the feedwater bypass valve loop around each main feedwater control valve, allows for "bumpless" automatic transfer from the lower power feedwater control system to the main feedwater control system, and vice versa. Also, no operator action is necessary whenever the nuclear power remains

in the range of automatic operation, even following small load or feed flow perturbations.

The bypass is sized for 25 percent maximum calculated flow and is capable of remote manual control from the control room. Both valves have handwheels for local emergency control and provisions for automatic closure upon receipt of signals from the Reactor Protection System.

## **REACTOR PROTECTION SYSTEM**

The Reactor Protection System (RPS) provides the following functions:

- Monitors the plant for abnormal conditions and alerts the operator to take appropriate action
- Automatically provides
  - reactor trip (shutdown) signals
  - engineered safeguards actuation signals when plant conditions, as monitored by nuclear instrumentation and process instrumentation, reach the plant safety limits

Variables which are monitored by the RPS pursuant to its trip function include:

- The process variables which are directly related to equipment mechanical limitations – such as pressure and pressurizer water level (to prevent water discharge through safety valves, and uncovering of heaters)
- The calculated variables which directly affect the heat transfer capabilities of the reactor – such as flow rate and reactor coolant temperature

Whenever a direct process or calculated variable exceeds a setpoint, the reactor will be shut down: to prevent fuel rod damage for an anticipated transient (Condition II); to limit core damage for infrequent faults (Condition III); and to protect the reactor coolant pressure boundary for limiting fault conditions (Condition IV). The RPS provides for manual initiation of reactor trip by operator action in the control room.

The RPS initiates a turbine trip signal whenever reactor trip occurs. This prevents excessive reactor system cooldown to preclude the reactivity insertions that would otherwise result, and thus avoids unnecessary actuation of the Engineered Safety Features Actuation System.

A simplified block diagram of the integrated Reactor Protection System is shown in Figure 7-9.

Reactor trip signals provided by the system are as follows:

- Manual trip signal – Redundant control board pushbuttons are provided.
- Neutron flux trip signals – Source, intermediate, low power range, and high power range signals are provided for protection during startup, full power, and shutdown operations. High flux rate trips protect the reactor in case of rod ejection or accidental rod drop
- Primary coolant trip signals – Departure from nucleate boiling ratio, kw/ft, low flow, and reactor coolant pump under-speed trip signals provide trips. The main purpose is to prevent core coolant conditions which could lead to excessive fuel or cladding temperatures or excessive bulk boiling of the coolant.

- Pressurizer trip signals – High pressure, low pressure, and high-level trip signals initiate a reactor trip
- Steam generator trip signals – Low feed-water flow and low water level trip signals protect against loss of steam generator water inventory. High water level trip signals protect against excessive water carryover into the turbine.
- Turbine-generator trip – Trip of the turbine-generator above a certain power level initiates a reactor trip
- Safety injection signal – Actuation of the Safety Injection System simultaneously initiates a reactor trip to prevent excessive reactor coolant temperature and/or pressure.

Along with the control systems described earlier, the protection systems switched from an analog computer system implementation to a microcomputer network implementation (Integrated Protection System) in the late 1970s. This change permitted more accurate and complex protection calculations. Examples of improvements permitted by the microcomputer network implementation include:

- Departure from Nucleate Boiling Ratio and kw/ft are calculated continuously and directly instead of using conservative but simplified proxies for them.
- Automatic testing facilities are improved. The test sequence is manually initiated and then proceeds automatically with a minimum of operator intervention. The test results are sent to the plant computer for processing and reporting.

- The operator can enter information on failed or "in test" segments of the system.
- The protection system normally uses 2/4 logic but reverts to a safe 2/3 logic when part of the system is being tested or is involved in maintenance. A 2/4 logic means that a trip occurs when at least 2 signals out of 4 indicate a trip condition.
- The trip breakers are arranged to provide a 2/4 configuration. The analog system provided 1/2 reactor trip breaker configuration.
- Preventive actions have been added such as automatic turbine runbacks which can prevent a trip condition.

### **Engineered Safety Features Actuation**

The protection system detects Condition II, III and IV faults and actuates the Engineered Safety Features. Table 7-1 lists the safety systems that may be actuated together with the events that trigger the actuation.



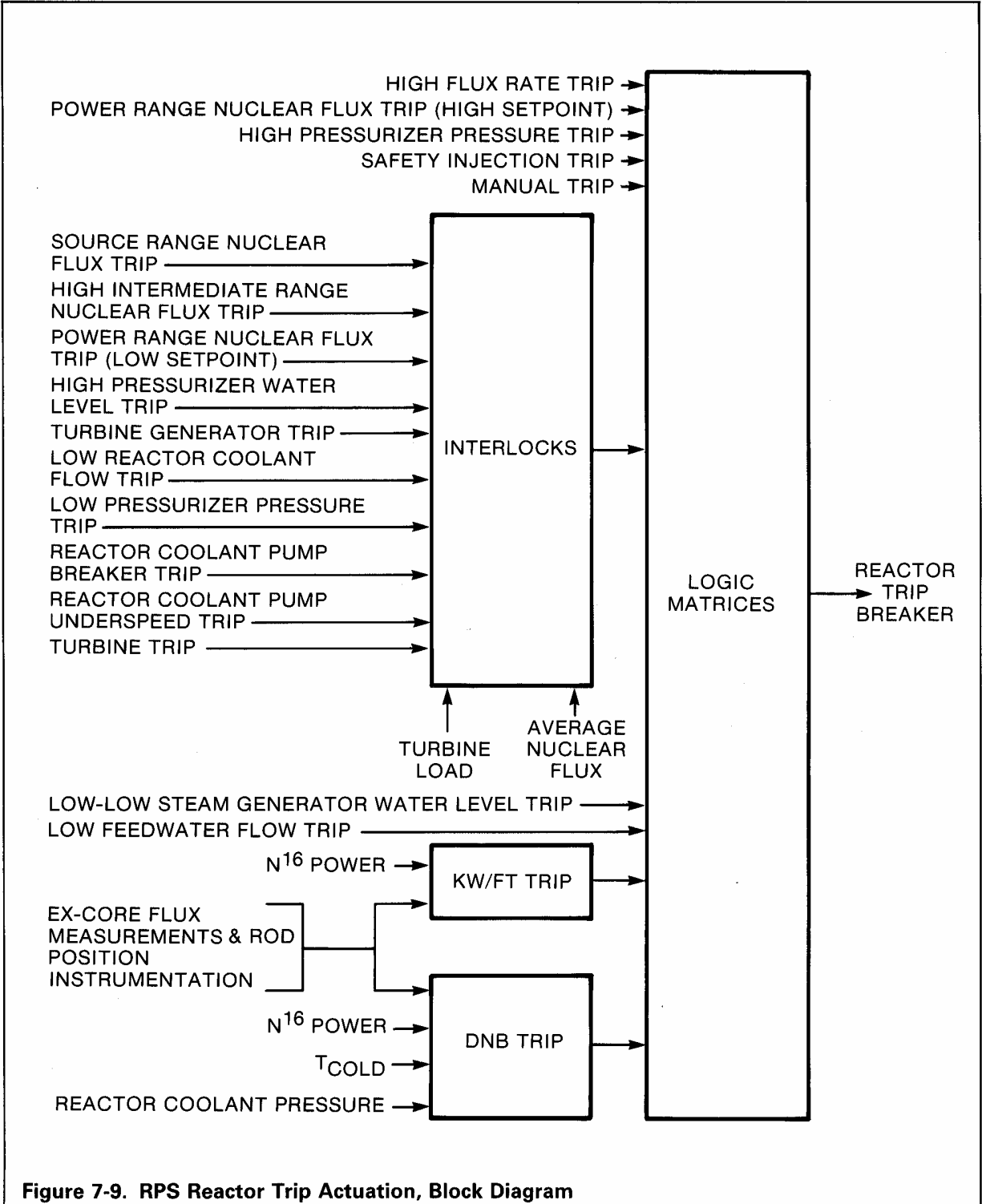

Figure 7-9. RPS Reactor Trip Actuation, Block Diagram

**TABLE 7-1  
ENGINEERED SAFETY FEATURES SIGNALS OF THE  
INTEGRATED PROTECTION SYSTEM**

<ul style="list-style-type: none"> <li>• Safety Injection               <ul style="list-style-type: none"> <li>Low pressurizer pressure</li> <li>High containment pressure</li> <li>Low steamline pressure</li> <li>Low <math>T_{cold}</math></li> <li>Manual safety injection</li> </ul> </li>   <li>• Containment Isolation Phase A               <ul style="list-style-type: none"> <li>Safety injection</li> <li>Manual</li> </ul> </li>   <li>• Containment Isolation Phase B               <ul style="list-style-type: none"> <li>High containment pressure</li> <li>Manual actuation of containment spray</li> </ul> </li>   <li>• Containment Spray               <ul style="list-style-type: none"> <li>High containment pressure</li> <li>Manual</li> </ul> </li>   <li>• Containment Vent Isolation               <ul style="list-style-type: none"> <li>Safety injection</li> <li>High containment reactivity</li> <li>Manual actuation of Phase A isolation</li> </ul> </li>   <li>• Steamline Isolation               <ul style="list-style-type: none"> <li>Low pressurizer pressure</li> <li>High containment pressure</li> <li>Low steamline pressure</li> <li>Low <math>T_{cold}</math></li> <li>High steam pressure rate of change</li> <li>Manual</li> </ul> </li> </ul>	<ul style="list-style-type: none"> <li>• Feedwater Isolation               <ul style="list-style-type: none"> <li>High steam generator level</li> <li>Safety injection</li> <li>Coincidence of reactor trip and low <math>T_{cold}</math></li> </ul> </li>   <li>• Open Accumulator Isolation Valves               <ul style="list-style-type: none"> <li>Pressurizer pressure above S1 unlock pressure</li> </ul> </li>   <li>• Turbine Trip               <ul style="list-style-type: none"> <li>Reactor trip</li> <li>High steam generator level</li> <li>Safety injection</li> </ul> </li>   <li>• Start Auxiliary Feed Pumps               <ul style="list-style-type: none"> <li>Safety injections</li> <li>Low steam generator level</li> </ul> </li>   <li>• Block Steam Dump               <ul style="list-style-type: none"> <li>Low <math>T_{cold}</math></li> </ul> </li>   <li>• Recirculation Phase               <ul style="list-style-type: none"> <li>Low RWST level</li> </ul> </li>   <li>• RHR/RCS System Interlock               <ul style="list-style-type: none"> <li>RCS wide-range pressurizer pressure above RHR operating pressure</li> </ul> </li>   <li>• RCP Trip               <ul style="list-style-type: none"> <li>High-head SI flow and SI signal</li> <li>Low wide-range RCS pressure</li> </ul> </li> </ul>
--	--

# chapter 8

## plant control room

The plant control room supplies all the data reduction and contains the display and control hardware needed to operate a nuclear power plant in a safe, efficient, and reliable manner. It is a total system which integrates human-engineered control board design along with a sophisticated computer system. A control room, however, can show considerable variation from plant to plant since it is designed to reflect a utility's operating philosophy.

A nuclear power plant is large and complex and the arrangement of devices for information input or control action output has resulted in large control boards like the one shown in Figure 8-1. The instruments and control stations are grouped by functional areas and by frequency of use. Infrequently used information and controllers may be located on the backs of panels or on isolated panels. Variations to the control room design is determined by utility needs.

In the earlier days of both fossil and nuclear power plant design, control board devices were grouped logically but heavy reliance was placed on the operator's skill. In the 1970s, Westinghouse devoted considerable study and effort to the human factors aspects of controlling a plant. As a result of this work and advances in electronic and computational technology, subsequent Westinghouse control board designs are significantly improved over the conventional control boards.

Most information about the plant's state is brought to the control room where control initiation devices are located (Tables 8-1 and 8-2). Other such devices although located elsewhere in the plant and designed for local

use are administratively linked to the control room.

## THE ADVANCED CONTROL ROOM

### Functional Aspects

The Advanced Control Room (ACR) optimizes the generation and display of useful plant information to the control room operator to enable him to rapidly understand the plant condition during both steady-state and transient conditions. The ACR consists of an integrated set of components which incorporates the latest technology in operator-oriented plant monitoring and supervision for the total nuclear plant operation.

The availability and operability of the plant are improved by the application of the following:

**Graphic Displays** – Over a dozen graphical display devices (CRTs and flat panel plasma displays) are located in the operations area of the control room. These devices present all plant parameters to the operator in optimized formats such as system flow diagrams, component flow diagrams, bar charts, and analog trends.

**Redundancy and Modularity** – Because the primary means of the plant information display is via graphical display devices, high system availability has been achieved by stressing redundancy and modularity.

**Key Dedicated Displays** – In addition to the cathode ray tube (CRT) displays and the required post-accident monitoring indicators, key process variables are presented via dedicated displays.

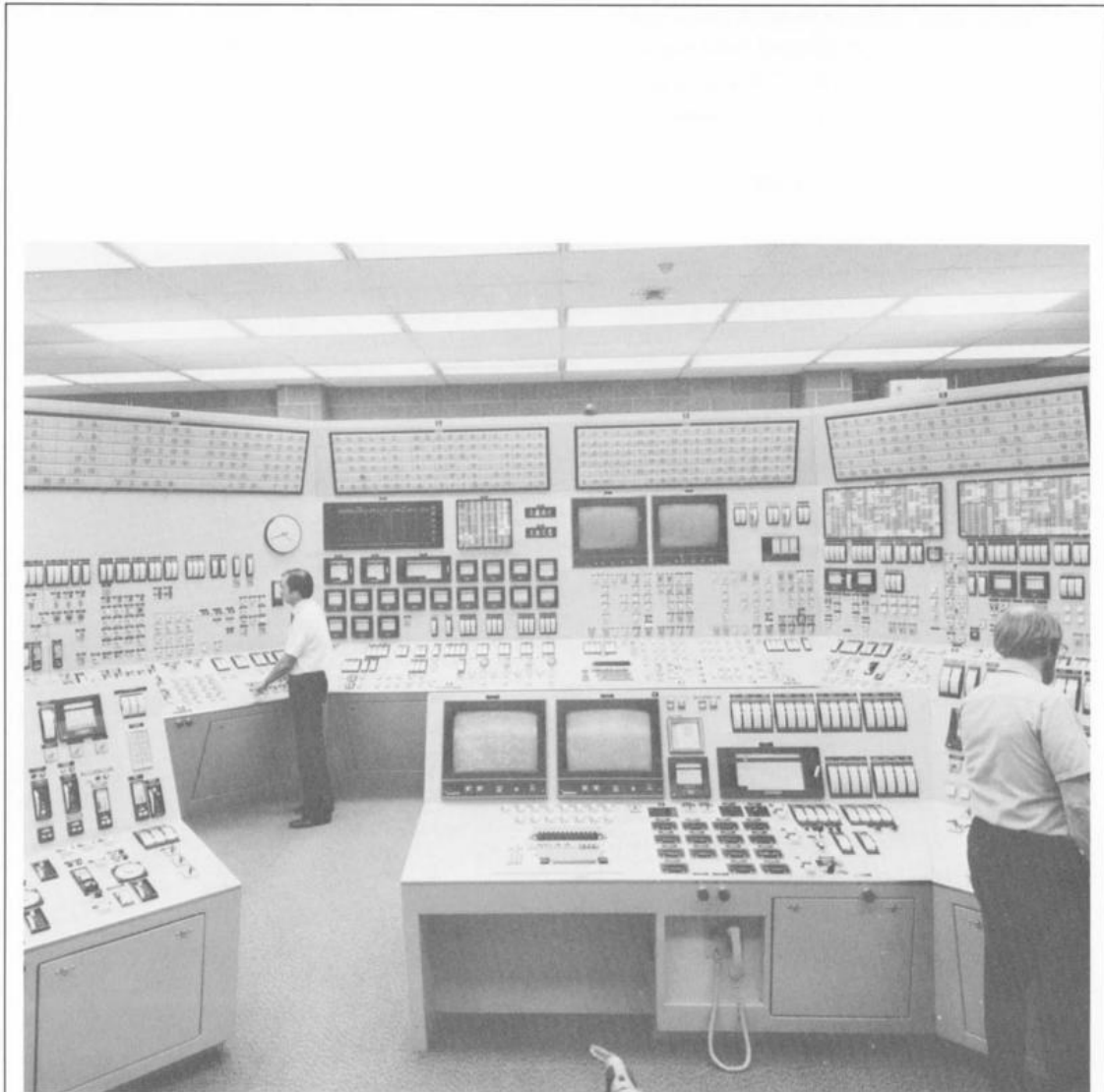

Figure 8-1. Typical Plant Control Room

**Human Factors Criteria** – All facets of the control room design have been subject to an iterative process of extensive research, testing and design to comply with applicable human factors criteria. This maximizes the flow of useful information to the operator and minimizes the probability of human error. Task analysis is incorporated as a primary design basis.

**Integration of NSSS-BOP Design** – The control room design integrates the NSSS and balance-of-plant (BOP) designs to present the operator with an effective man-machine interface which is consistent for all plant systems. This consistency aids in the decision making process regarding plant operation and the implementation of those decisions.

<b>TABLE 8-1 CONTROL ROOM INFORMATION DEVICES</b>	
<b>Device</b>	<b>Characteristics and/or Use</b>
Meters	One parameter/meter pointer
Lights	Typically status indication
Pen recorders	One parameter history/pen
Control rod position	Indicates rod positions by lighted lights
Light array panels	
Printers	Driven by the computer, can provide a wide variety of information as needed
Cathode ray tubes	Can quickly present a wide variety of alpha numeric information as needed
Alpha numeric	
Graphical	Can quickly present a wide variety of information in different formats as needed
Visual display panels	Provides a limited number of numeric and;-or alphanumeric characters by a selective lighting technique
Horns, buzzers, bells, etc.	Used to attract attention to a significant situation. Turned off by operator acknowledgement
Annunciator panels	A grouping of status lights to indicate malfunction conditions. An audible device is often associated with a group of the lights
Flat panel displays	These devices are similar in use to cathode ray tubes but they are more rugged and may have less display capacity
Alpha-numeric	
Graphical	

**Operator Control Placement** – Controls have been segregated into operating areas which optimize the location of frequently used and important controls thereby more clearly presenting the operator with the devices he requires.

**Safety System Integration** – Comprehensive systems to monitor the plants safety and safety related equipment operability status and to

assist in the response to unlikely significant malfunctions have been developed and integrated into the Advanced Control Room.

**Power Distribution** – No single failure in the power distribution system will result in degradation of the control area functions, except for ancillary or nonessential performance features whose failure would not decrease plant availability.

**TABLE 8-2  
CONTROL ROOM OPERATION ACTION DEVICES**

Device	Characteristics and/or Use
Switch	Establish a control status, such as on-off, open-closed, etc. may be used in combination with other devices and or other switches for fairly complex control arrangements.
Pistol grip switch	Typically three positions, rotates in plane parallel to board surface – angular position indicates state.
Dials	Enters values, used for establishing setpoints, etc.
Pushbuttons	Serve as switches, may be grouped to establish fairly complex control arrangements. Often push to change state and back lighted to show state.
Switch, servo, meter combination	Used to enter values, establishes setpoints, etc. May directly control a setting, such as a valve position.
Keyboard	May be full typewriter style keyboard or a limited subset. Usually enters data through a computer or other processor. It can be very flexible and powerful.
Cathode ray tube devices Light pen Cursors Keyboards	Usually enters data through a computer or other processor. It can be flexible and powerful.

## Control Centers

The basic control centers (integrated NSSS/BOP) which make up the Advanced Control Room are as follows:

**Primary Control Center (PCC)** – The PCC is the location for all controls, displays and instrumentation required for normal power operation including load follow from hot standby to 100-percent power. The NSSS and BOP controls, displays and instrumentation are integrated into a unified arrangement to optimize operator understanding of the plant status while minimizing his movements required for plant control. The PCC allows for plant operation by one or two operators from a seated position who have visual command of the auxiliary control panels. Graphic displays are available at the PCC to provide the operator with symbolic flow charts, parameter trends, alarms, plant status, safety systems availability, instruction, and other operational messages for all plant systems controllable from the control centers.

**Auxiliary Control Panels** – The auxiliary control panels contain all the controls, displays and instrumentation less frequently used and not mounted at the PCC. Included are the safety systems and functions which are arranged in stations each dedicated to a single train of safeguard systems and equipment. Other non-train-oriented, and other train-related instrumentation and controls are placed at the train-oriented stations with suitable separation, or at separate stations. Graphical displays are used to display the status and performance of the various safety systems, including the Bypass and Inoperable Status Indication and Safety Parameter Display Systems.

**Results Center** – The Results Center provides a central facility for recording system data. It has a CRT display with an interactive keyboard that will allow plant personnel the flexibility to modify any of the display systems provided by the computer. The Results Center includes an engineering station which is capable of displaying the information from any of the control center CRT displays, as well as displaying and/or printing hard copy of the results of special computer calculations such as the results of system automatic testing, instrument calibrations, and core calculations.

**Supervisor's Center** – The Supervisor's Center is located in the control room to give visual access to the other control centers. It has a CRT and flat panel readout display capability with interactive keyboards providing the ability to call up any display available at the other control centers.

## Continued Control Room Evolution

Control rooms are continuing to change as we learn more about human factors and as new technology becomes available. As an example, the detection of and response to malfunctions is improving significantly as new developments in the artificial intelligence technology are integrated into the control room. Artificial intelligence is the art of making a computer system carry out algorithms so that its operation is somewhat like a human's thought process.

## Control Room Layout

A typical layout for the ACR (Figure 8-2) locates the Primary Control Center as the focal point for plant operation. The auxiliary panels are located



for easy access from the PCC. The Supervisor's Center is located to afford visual command of the operating stations. The Results Center can be located in either the control room, the computer room, or any other area suitable to the auxiliary building design.

### **ON-SITE TECHNICAL SUPPORT CENTER AND EMERGENCY OPERATIONS FACILITY**

The On-Site Technical Support Center (OTSC) and the Emergency Operations Facility (EOF) aid in post-event recovery activities, provide a powerful plant monitoring capability, and provide communications with external organizations in the unlikely event of a significant nuclear accident. For higher level emergencies and optionally other emergencies, the management of the response, monitoring of the situation, direction of off-site activities, and communication with external organizations is performed in the EOF.

Basically, the OTSC's function is the direction of recovery activities in the plant and, for emergencies through the alert class, management of the total response to the accident. As a focal point for post-accident recovery activities it must have the capability to display and transmit plant status information to those technical personnel who are responsible for engineering support of reactor operations during post-accident recovery. The major functions for which the OTSC provides direction or a support role include the following:

- Ensure that the plant is in a safe and stable shutdown condition following an accident.
- Direct plant post-accident recovery operations.

- Prevent violation of a radioactivity control boundary not compromised by the original accident.
- Keep on-site and off-site radiation exposures within acceptable levels.

These two centers are essentially strategic control rooms for use during an unlikely significant accident to separate the strategic and tactical aspects of plant control during the crisis. The people utilizing these centers are technically oriented experts who may not have had experience in operating the center. Therefore, these centers are both natural and easy to use, and provide a powerful information retrieval, processing, and display capability to support the experts' analysis.

The EOF is the focal point for the management of the overall emergency response, the coordination of radiological assessments, and for the management of recovery operations. The EOF provides direction in the decision-making process, to protect the public health and safety, and to control radiological monitoring teams and facilities on-site and off-site. As such, the EOF has the capability to display meteorological data, radiological data, and plant systems information.

The man-machine interfaces are designed with consideration of human characteristics and existing power industry procedures and practices. Industry-accepted mnemonics, descriptors, and displays are used. The sophisticated man-machine interface allows the infrequent user access to information without requiring special training or instruction. Special displays and prompting information provided with the commonly used keys make this possible. The man-machine interface also allows the experienced user to access the information of

interest, without stepping through inter-mediate displays designed to help the novice user.

The OTSC and EOP have the capability to access and display plant parameters indepen-

dent of actions in the Control Room. The interface of their instrumentation with existing plant instrumentation will not result in any degradation of the Control Room, protection systems, controls, or other plant functions.

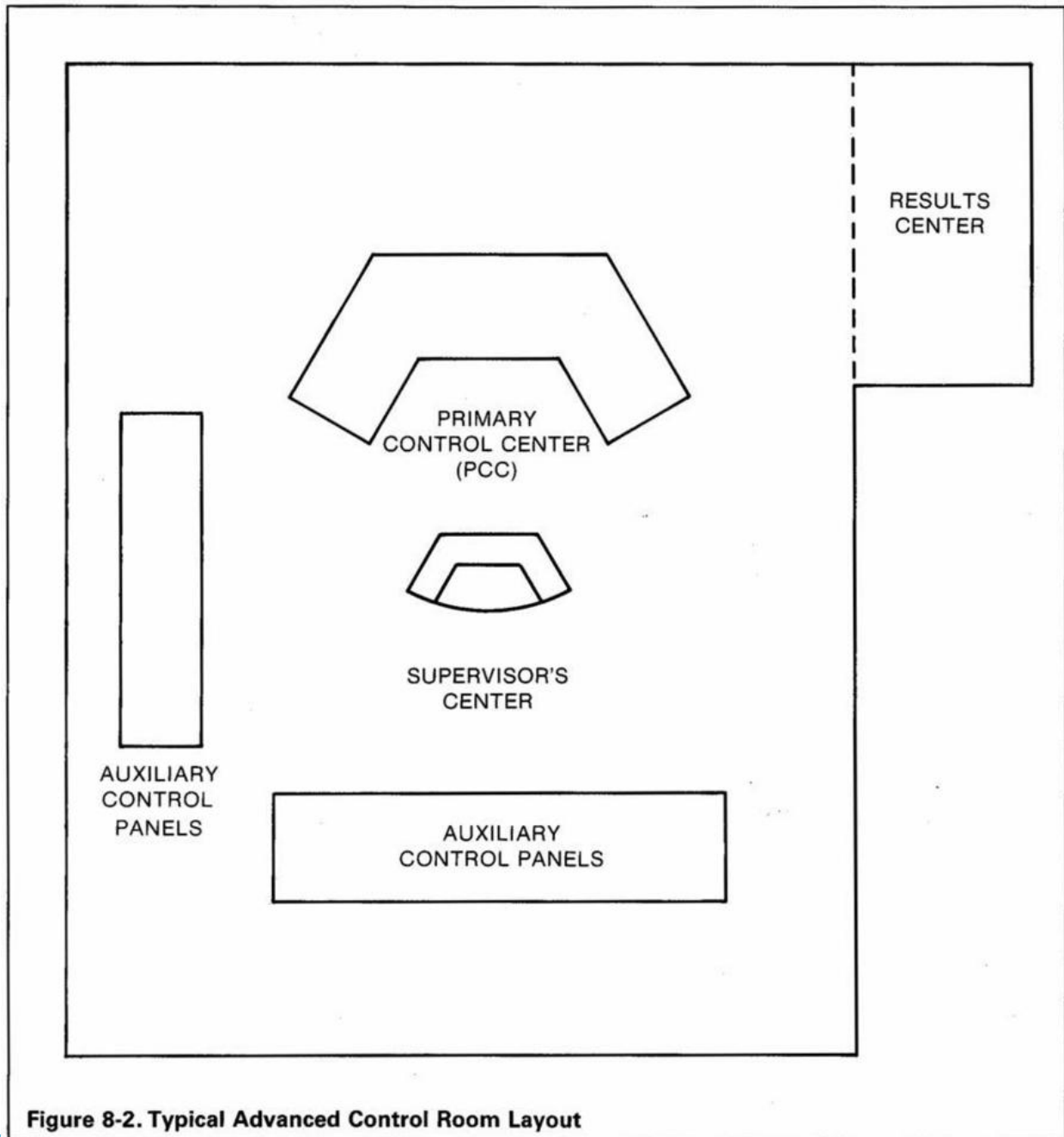

Figure 8-2. Typical Advanced Control Room Layout

# chapter 9

## plant computer

Although not absolutely essential to plant operation, the plant computer is an immensely powerful tool for providing information organized in a manner best suited to the operator's needs. The computer collects data from many locations within the plant and then processes it to provide a variety of information:

- To enable the operator to have a good understanding of the plant's operation as he needs it for making decisions.
- To provide a historical record to the plant's engineering staff to help analyze the plant's operation and for permanent record retention.
- To help analyze malfunctions and help plan the recovery from significant malfunctions.

Because computers are flexible devices and because computer technology has been advancing rapidly, there is a wide range of computer configurations in the different Westinghouse PWR plants. The computers in the latest plants are considerably more powerful and flexible and are more firmly based on human engineering principles than those in the earliest plants, and future plants will see a continuation of this trend. The basic mission and principles hold for the entire series, even though this description is based on the computer system of the mid-1980s.

### **Information into the Computer**

The plant interrogates the plant's parameters by:

- Data links from other processing devices
- Analog/digital conversions of signals from a variety of analog sensors

- Digital inputs, which are scanned either every second or when one of a group of contacts changes its state
- Pulse inputs, which are typically accumulated to give rates or total values.

Information, computer programs, data and commands can be entered into the plant computer by the operator or programmer by using keyboards and switches, paper tape readers, card readers, magnetic tape readers, and cathode ray tube entry devices such as interactive keyboards and cursor control devices.

### **Information from the Computer**

The computer can make its information available through a range of devices in different formats to present the information in the most useful form.

Table 9-1 summarizes the formats available. In the table, the mimic display is defined as a display combining a diagrammatic representation of a system and the values of key parameters in the system. The polar display format indicates values as the length of spokes of a wheel, with each value normalized so that the reference values are all the same for normal operating conditions.

### **MAN-MACHINE INTERFACE**

A key factor in the usefulness of a computer system is the knowledge and skill needed for an operator to interact with the computer. The usefulness increases as the skill and knowledge required decreases and as the clarity of the information presented improves. Providing this extra usefulness requires additional computer resources and improved computer programs. This man-machine interface has been improved

**TABLE 9-1  
COMPUTER INFORMATION DEVICES**

<b>Device</b>	<b>Format</b>	<b>Feature</b>
Cathode ray tube (CRT) and flat panel display	Mimic (Figure 9-1)	Provides quick response and timely information Pictorially models a system Aids operator comprehension
	Bar chart (Figure 9-2)	Provides a sense of relative values
	Tabular	Effective method of presenting large quantities of data
	Graphical (Figure 9-3)	Aids in comprehension of relationships
	Data trends	Aids in comprehension of time related changes
	Polar graphical (Figure 9-4)	Shape changes indicate abnormal situations. Supports problem diagnosis on the basis of symptoms.
Video, hard copier	Same as CRT	Provides a record of CRT displays on demand
Typer	Wide variety of alpha numeric formats	Provides record for length of time desired. Can provide large volume of data in many formats.
Line printer		Same as typer with high speed
Bell or buzzer	Audible	Gains attention
Pen recorder	Data trends	Provides hard copy record of a function's time history
Lights	On-Off	Indicates status
Meters and visual display, panels	A value	Indicates a parameter's value
Magnetic tape	Bit patterns	Compactly stores voluminous information for later discretionary use

as new computer systems are developed for plant operation. Some of the improvements are as follows:

- Presents “current use” information on CRT displays instead of on printouts.
- Provides more effective display format such as mimic diagrams, graphs, and bar charts.
- Introduces operator task analysis as a means of defining interface needs.
- Applies latest human engineering principles to display designs.

- Provides greater ease of identifying needed information. Earlier systems used a series of codes; new systems present selection information on displays so that much information can be reached by a natural chaining through displays. The design of the chaining process is based on human factor principles.

## COMPUTER SYSTEM FUNCTIONS

### General Service Functions

These are functions that are general in nature and support or interact with the other computer system functions. They are listed below with some clarifying comments.

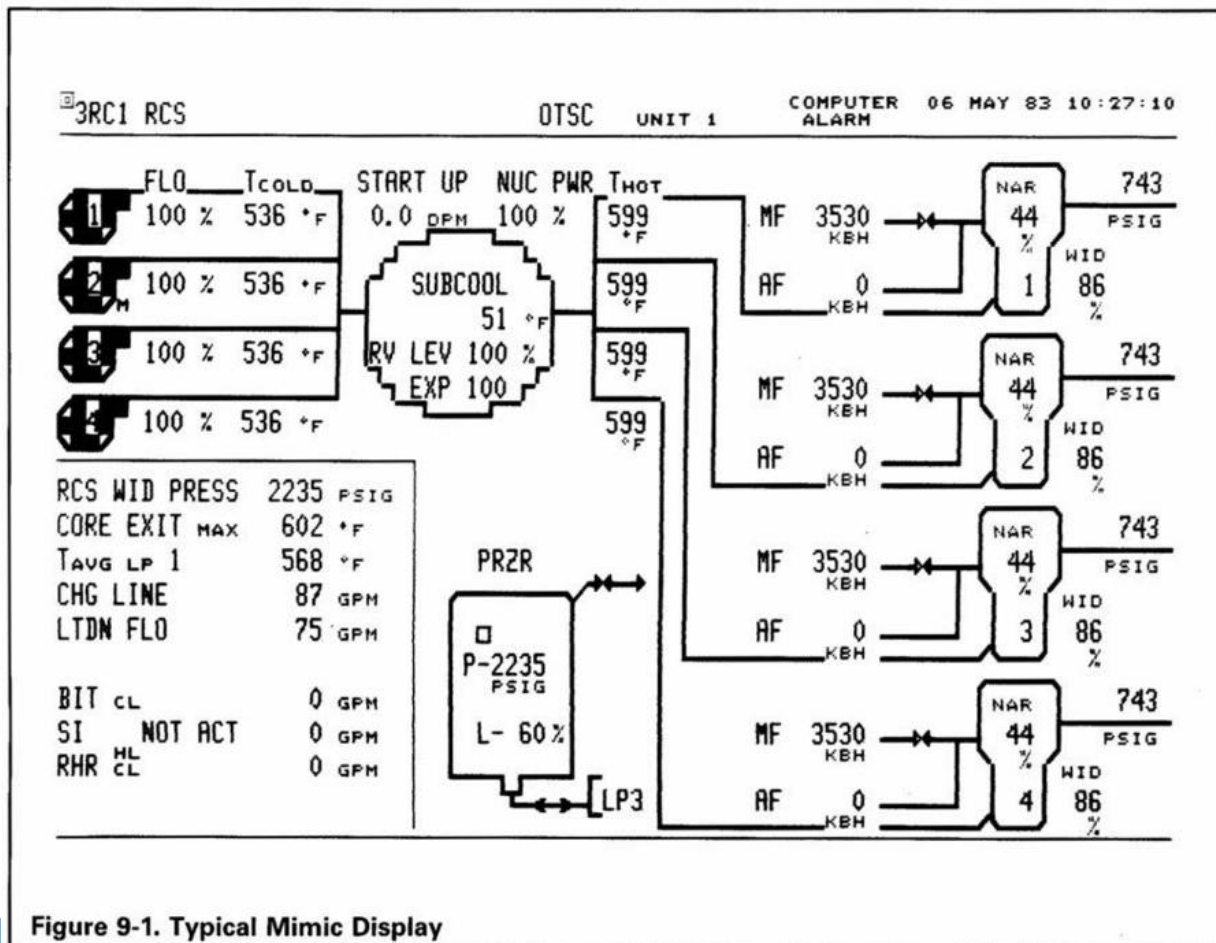
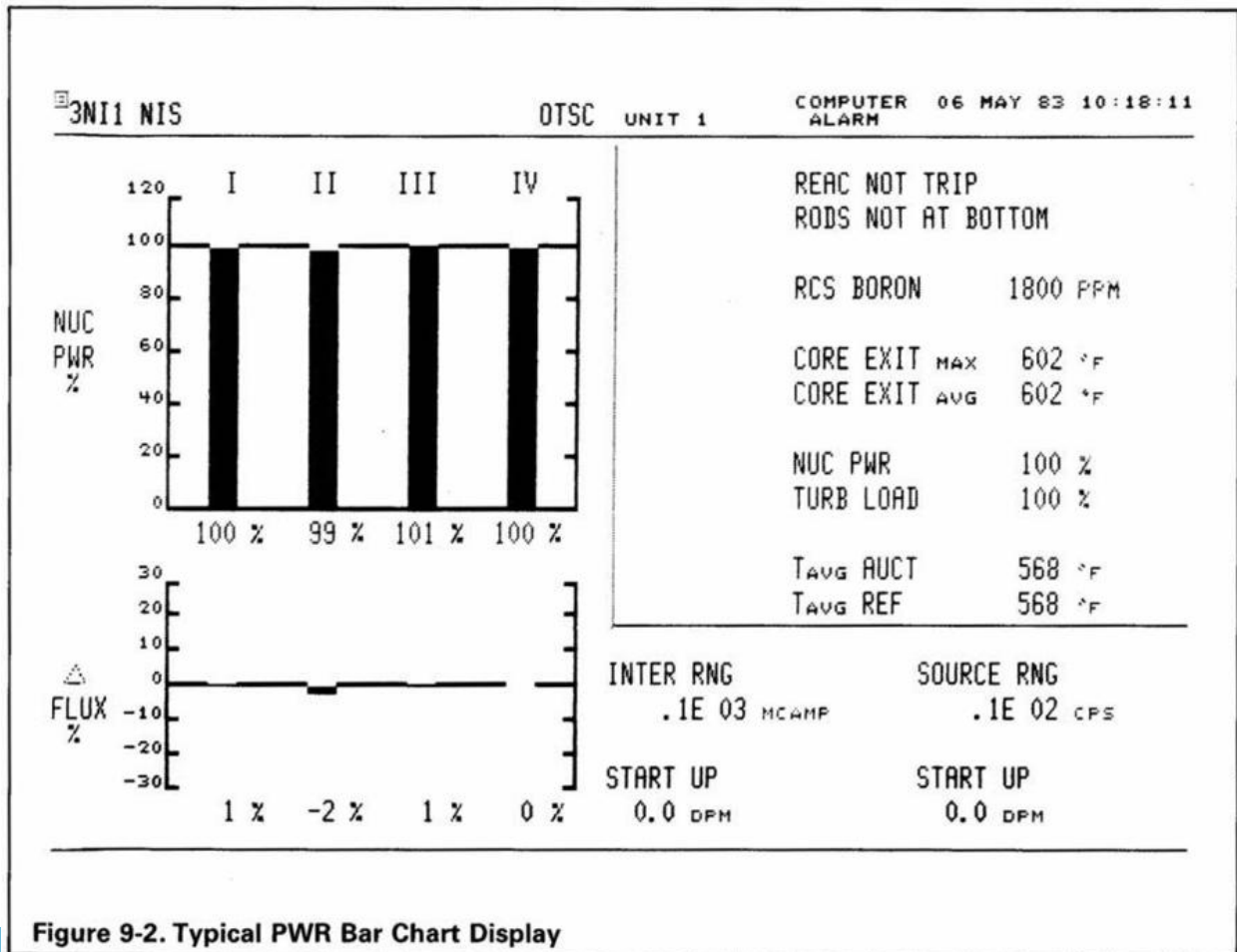

Figure 9-1. Typical Mimic Display

- Analog input scanning and conversion.
- Contract input scanning.
- CRT handling – Establishes CRT pictures and responds to commands entered through the CRT devices (keyboard, joy stick, etc.).
- Sensor calibration – A procedure to establish conversion constants for a sensor.
- Periodic and demand logs, including digital trends – Printed values for a group of variables at specified times that may be generated on typers, line printers, or CRTs.
- Reviews – for a group of variables, reports on a status or condition such as alarm status, sensor scan status, values, limits, setpoint.
- Change computer tasks or parameters – Such as scan rate or status, alarm limits, log composition or frequency, program status.
- Request data – Such as certain calculations or reports or specific data items.
- Data storage and retrieval – The automatic storage of time history data and procedure for retrieval.



## Reactor Control and Protection System Supervision

These functions listed below enhance the reactor control and protection systems by reporting on their status, by duplicating or checking some of their calculations and operations, and by providing a few extra checks.

- Reactor coolant average loop temperature setpoint
- Pressurizer level controller setpoints
- Control rod position monitoring and checking
- Reactor protection system monitoring
- Deviation in redundant measurements

- DNB and kw/ft calculation
- On-line test results documentation.

## NUCLEAR STEAM SUPPLY SYSTEM PROCESS SUPERVISION

These functions provide data about the operation of the nuclear power plant. A few of these functions are optional and others could be added.

- Calibration check of power range channel signals
- Reactor dynamic thermal output
- Steam generator total thermal output

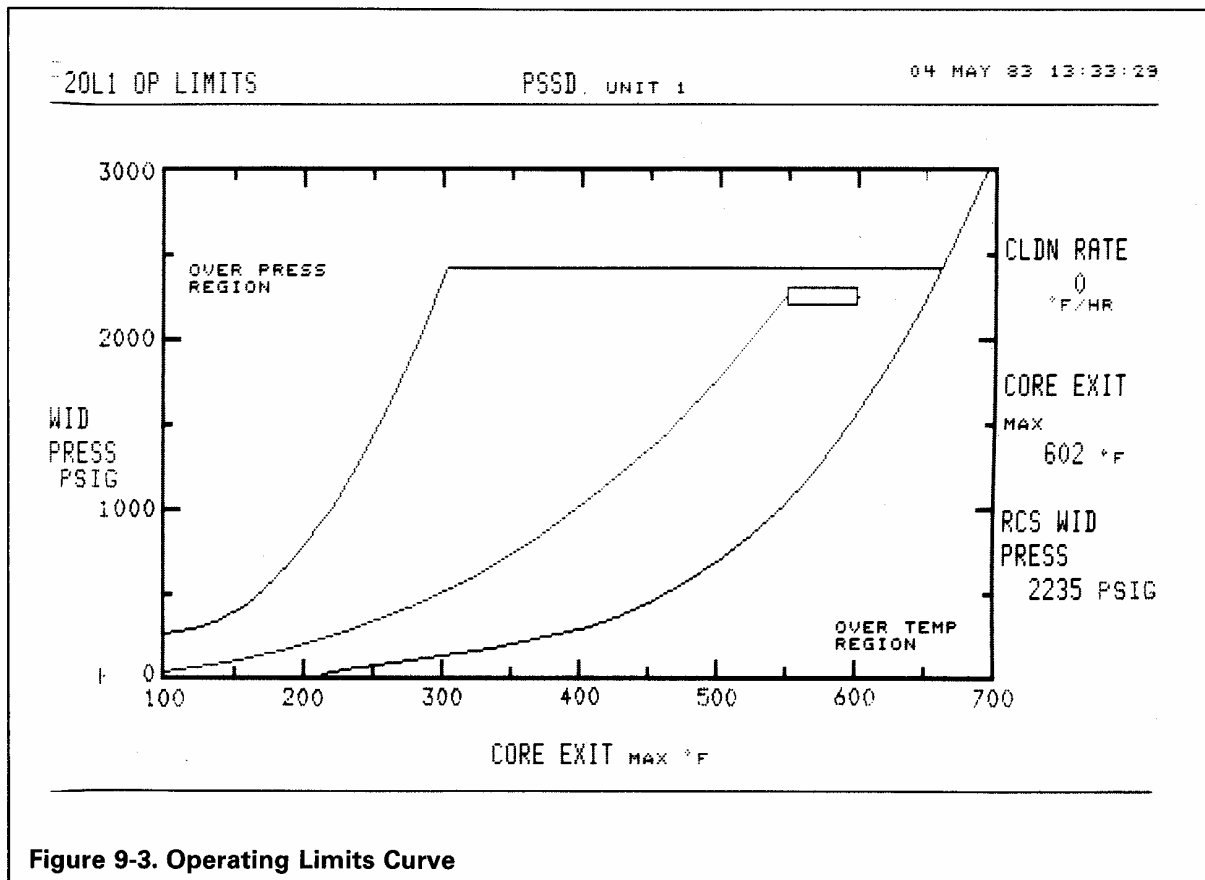
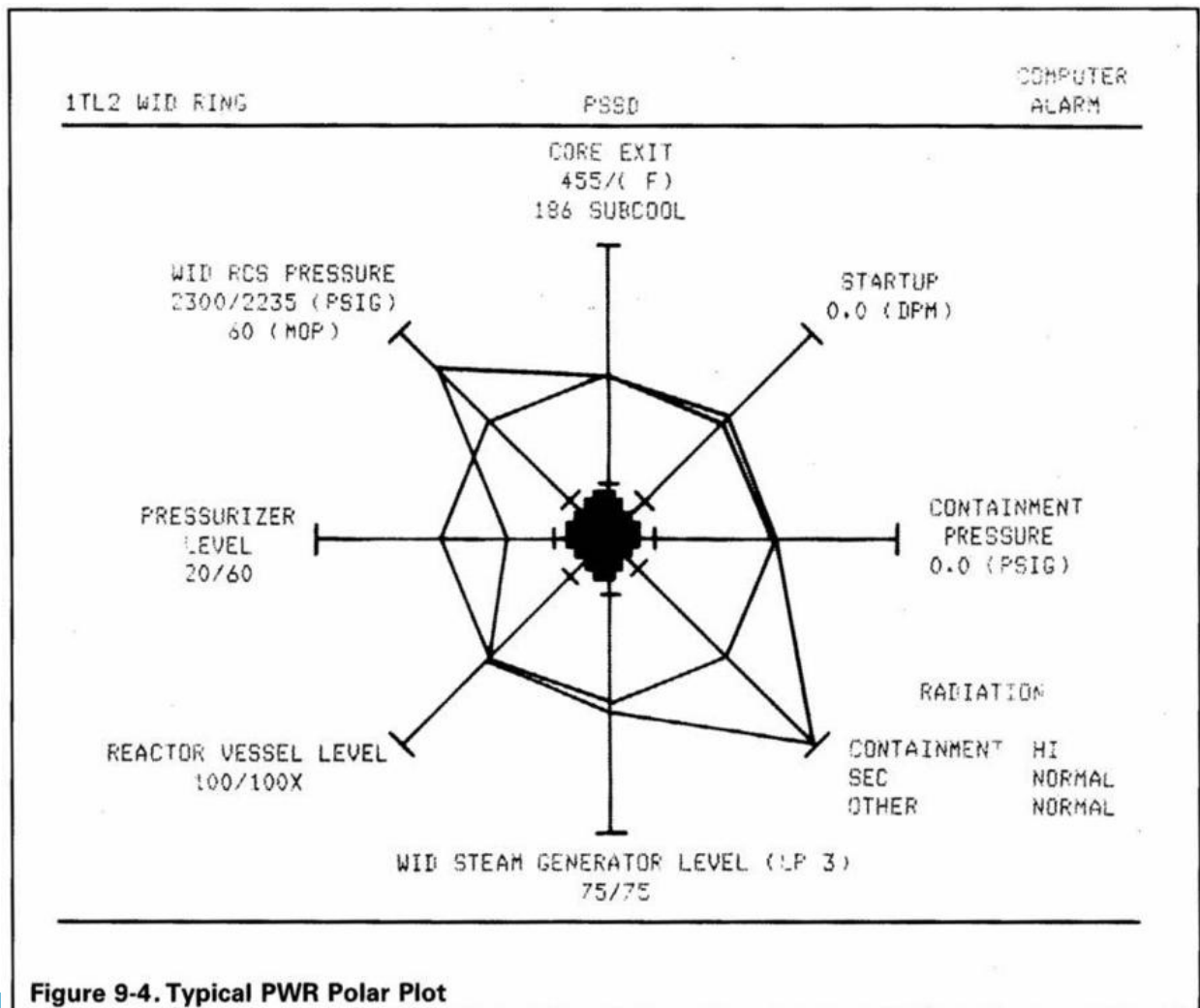

Figure 9-3. Operating Limits Curve



- Unit net efficiency
- Tilting factors\* (steam generator thermal output tilt, reactor coolant  $\Delta T$ 's tilt, radial and axial flux tilt).
- Calculation of reactivity conditions and factors, for the present, the future, and some operator postulated conditions.
- Collection and formatting of in-core data from the movable detector system and in-core thermocouples.
- INCORE program – Performs an operational core analysis function.
- Secondary plant performance calculations.
- Large motor monitoring.

\* A tilt is an unbalance in a set of parameters that could be balanced.



## Malfunction Detection and Response

These functions assist in the detection of malfunctions of various degrees of severity, provide information needed to analyze a malfunction, provide information about the ability to respond to a malfunction, and/or provide assistance in responding to a malfunction.

- Alarming – Checks for individual parameters exceeding limits.
- Safety Parameter Display System – Presents a succinct display account of the overall plant safety status.
- Bypassed and Inoperable Status Indication – Provides information on the ability of the safety systems to respond to a significant malfunction.
- Onsite Technical Support Centers and Emergency Offsite Facility Functions – Provides information to these facilities to aid in the recovery from a significant malfunction.
- Post trip review – Prints a history of parameter values before and after a trip.
- Sequence of events recording.

# **chapter 10**

## **radiation**

### **monitoring system**

The function of the Radiation Monitoring System is to monitor radiation levels at selected plant locations. If these levels exceed predetermined normal or safe values, alarms are activated and in some cases automatic protective functions initiated. Thus the system serves to:

- Warn of any radiation health hazard
- Give an early warning of a plant malfunction
- Initiate automatic protective functions.

Table 10-1 lists the monitors along with each's sensitivity range and location in the plant.

## **DIGITAL RADIATION MONITORING SYSTEM**

The Westinghouse Digital Radiation Monitoring System (DBMS) is a distributed microprocessor based system with local control units linked to the higher level microprocessor controlled communications console utilizing a star configuration. The DRMS (Figure 10-1) consists of a Communications Console, Data Processing Modules, a Safety Related Display Console, Radiation Monitors, and an optional Mini-computer.

The Communications Console is the central communications and control unit for the DRMS. Each radiation monitor data processing module is linked to the Communications Console, where monitor status and radiation activity data from all monitors are displayed on a CRT/keyboard and remote printer terminal. The Communications Console can also be linked to an optional minicomputer for further data processing and storage.

The Communications Console interrogates the data processing modules in rotation, and the

data modules respond with change-of-status information or transmit radiation data as requested. To minimize the system response time, the Communication Console uses a multiplexing technique to interrogate groups of data modules simultaneously.

The Data Processing Modules receive and count pulses from radiation detectors. Depending on the type of monitor application, this data is displayed as counts per minute, milliroentgens per hour, or as microcuries per cubic centimeter. Background radiation is considered in obtaining an accurate measurement of the sample.

The data is stored in the data processing module memory and can be read out on command. This local storage of the data protects the DBMS against loss of the data in the event of a temporary loss of communications to the Communications Console or minicomputer.

The Safety Related Display Console (SRDC) provides remote control and status display of the safety monitor channels in the control room. The SRDC panel has a designated display/control area for each safety channel. Communications with safety data modules from the SRDC is over dedicated hard wire. A simplified block diagram of the safety system is shown in Figure 10-2.

The SRDC has a digital readout panel display for each channel. In normal use, the readout continuously displays the radiation activity level being monitored by its respective detector channel. By use of a rotary function selector switch, the readout can be made to display the channel parameters and setpoints which have been placed in the memory of the related data module. A programming switch is also provided in the SRDC for each safety monitor channel to allow the operator to alter or adjust the channel

**TABLE 10-1  
RADIATION MONITORING SYSTEM TYPICAL MONITORS**

Item Monitored	Safety Class	Location	Sensitivity Range
Area	NNS	Control room	$10^{-2}$ to $10^3$ mr/hr
Area	NNS	Radio-chemical laboratory	$10^{-1}$ to $10^4$ mr/hr
Area	NNS	Fuel handling building	$10^{-1}$ to $10^4$ mr/hr
Area	NNS	Sample room	$10^{-1}$ to $10^4$ mr/hr
Area	NNS	In-core instrumentation room	$10^{-1}$ to $10^4$ mr/hr
Area	NNS	Containment access hatch	$10^{-1}$ to $10^4$ mr/hr
Area	NNS	Decontamination station	$10^{-1}$ to $10^4$ mr/hr
Area	NNS	Technical support center	$10^{-2}$ to $10^3$ mr/hr
Area (high)	SC-3/IE	Containment	$10^3$ to $10^{11}$ mr/hr
Area (low range)	SC-3/IE	Containment	$10^{-1}$ to $10^4$ mr/hr
Air particulate (high)	Cat. 2	Plant ventilation	Passive cartridge
Air particulate (low)	NNS	Plant ventilation	$10^{-11}$ to $10^{-6}$ $\mu\text{c}/\text{cc}$
Iodine (high)	Cat. 2	Plant ventilation	Passive cartridge
Iodine (low)	NNS	Plant ventilation	$10^{-11}$ to $10^{-6}$ $\mu\text{c}/\text{cc}$
Radioactive gas (high)	Cat. 2	Plant ventilation	$5 \times 10^{-6}$ to $10^4$ $\mu\text{c}/\text{cc}$
Gas (low)	NNS	Plant ventilation	$5 \times 10^{-7}$ to $5 \times 10^{-2}$ $\mu\text{c}/\text{cc}$
Air particulate	NNS	Containment vent	$10^{-11}$ to $10^{-6}$ $\mu\text{c}/\text{cc}$
Iodine	NNS	Containment vent	$10^{-11}$ to $10^{-6}$ $\mu\text{c}/\text{cc}$
Radioactive gas	NNS	Containment vent	$5 \times 10^{-7}$ to $5 \times 10^{-2}$ $\mu\text{c}/\text{cc}$
Air particulate	NNS/Seismic	Containment atmosphere	$10^{-11}$ to $10^{-6}$ $\mu\text{c}/\text{cc}$
Iodine	NNS/Seismic	Containment atmosphere	Passive cartridge
Radioactive gas	NNS/Seismic	Containment atmosphere	$5 \times 10^{-7}$ to $5 \times 10^{-2}$ $\mu\text{c}/\text{cc}$
Air particulate	NNS	Waste solidification	$10^{-11}$ to $10^{-6}$ $\mu\text{c}/\text{cc}$
Iodine	NNS	Waste solidification	$10^{-11}$ to $10^{-6}$ $\mu\text{c}/\text{cc}$
Radioactive gas	NNS	Waste solidification	$10^{-11}$ to $10^{-6}$ $\mu\text{c}/\text{cc}$
Radioactive gas	SC-3/IE	Control room air intake	$10^{-6}$ to $10^{-1}$ $\mu\text{c}/\text{cc}$
Liquid	NNS/Seismic	Component cooling water	$4 \times 10^{-7}$ to $4 \times 10^{-2}$ $\mu\text{c}/\text{cc}$
Liquid	NNS	Waste liquid	$10^{-6}$ to $10^{-1}$ $\mu\text{c}/\text{cc}$
Liquid	NNS	Steam generator sample	$4 \times 10^{-7}$ to $4 \times 10^{-2}$ $\mu\text{c}/\text{cc}$
Liquid	NNS	Service water	$4 \times 10^{-7}$ to $4 \times 10^{-2}$ $\mu\text{c}/\text{cc}$
Liquid	NNS	Steam generator blow down	$4 \times 10^{-7}$ to $4 \times 10^{-2}$ $\mu\text{c}/\text{cc}$
Steam line	SC-3/IE	Main steam line monitor	$10^{-1}$ to $10^3$ $\mu\text{c}/\text{cc}$
Radioactive gas	NNS	Condenser air ejector	$5 \times 10^{-7}$ to $10^5$ $\mu\text{c}/\text{cc}$

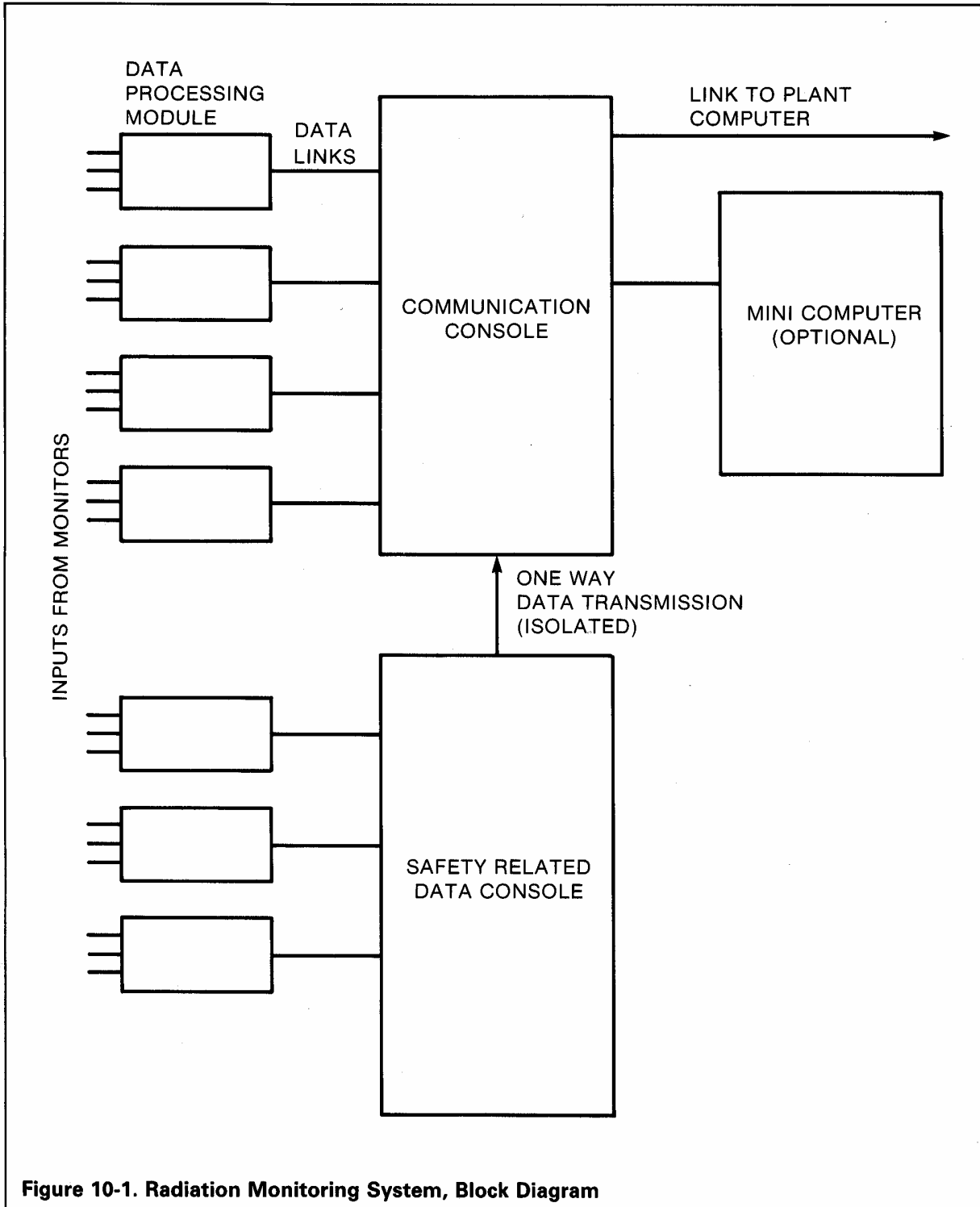

**Figure 10-1. Radiation Monitoring System, Block Diagram**

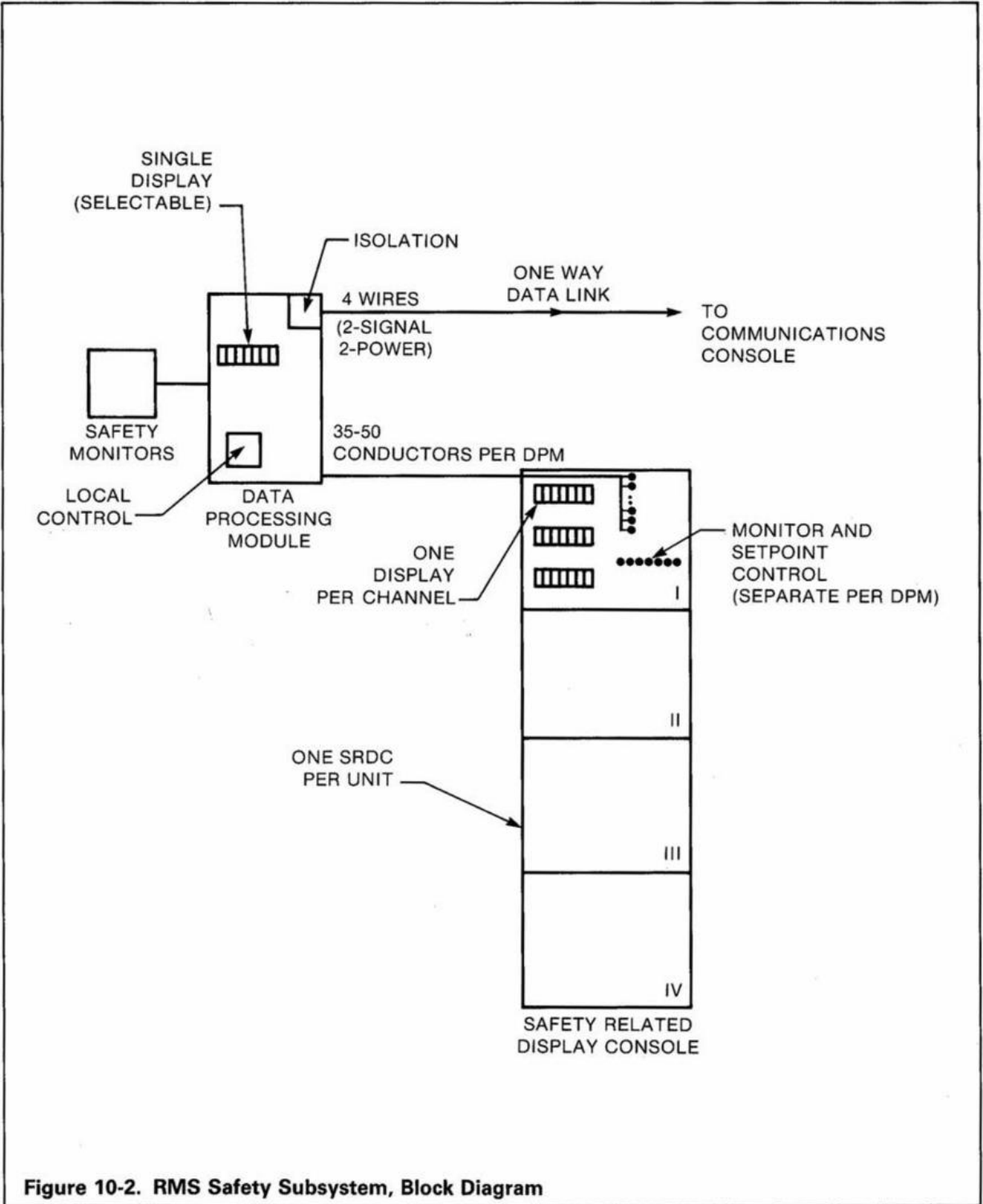

**Figure 10-2. RMS Safety Subsystem, Block Diagram**

parameters or setpoints. Additional switches are provided to control other functions, such as test, check source activation, paper advance, etc. Control of safety channels from the Communication Console is not possible. However, isolated outputs to the Communication Console from the safety channels are provided so that safety-related data can be displayed at the Communications Console.

Several types of radiation monitors are used in the DBMS, depending on the source and strength of the radiation source.

- Air particle monitors

These monitors pass an air sample through moving and stationary paper filters. The moving paper filter moves to a radiation detector which surveys the collected matter. Passive monitors may survey the stationary filter in place or it can be removed and taken to the health physics laboratory for analysis.

- Gas monitors

These monitors fall into two categories.

- In-line monitors which pass a sample of gas past a radiation monitor to determine the level of radioactive gases present in the sample. This type may be used in conjunction with an air particle and/or iodine monitor.
- On-line gas monitors which surround the pipe carrying the gas, and monitor the radiation level through the pipe walls.

- Iodine monitors

The iodine monitor collects the iodine in a filter cartridge and either monitors the radiation level directly via a radiation detector

or passively where the cartridge is removed and monitored in the health physics lab.

- Area monitors

These, as the name implies, monitor an area where personnel access is necessary for plant operation/maintenance. These monitors utilize radiation detectors which cover the area in which they are located.

- Steamline monitor

The steamline monitor is located on the steam line and monitors the radiation levels through the steam line walls. Shielding surrounds the detector.

- Liquid monitors

These monitors pass a sample of the liquid effluent through a sample volume and monitor the volume with a radiation detector. The monitors utilize a pump, when necessary, to circulate the liquid where system differential pressure between inlet and outlet point is not sufficient.

- In-vent gas detectors

These monitors are located in the vents and directly monitor the radiation in the vents.

The above monitors serve various specific applications and are designed to appropriate specifications such as safety grade requirements, seismic qualification, or in the case of liquid monitors, ASME code requirements. In addition, the ranges of the monitors are varied to meet their service requirements, such as post-accident, wide range, narrow range, or low range. This building block approach allows the DBMS system to be tailored to each plant's specific needs.



# **chapter 11**

## **plant electrical systems**

The Electrical System for the power plant is designed to provide a diversity of reliable power sources which are physically and electrically isolated so that any single failure will affect only one source of supply and will not propagate to alternate sources. The plant electrical systems consist of the main power system and the auxiliary power system. The main power system is made up of the plant main generator and the associated controls necessary to transmit power to the off-site distribution grid. The auxiliary power system is made up of sources of power from the off-site main distribution grid and a supply from the plant main generator when the main generator is in operation. These two supplies of electrical power are normally termed system auxiliary power and unit auxiliary power, respectively.

The system auxiliary power is supplied from independent and electrically isolated buses of the off-site main distribution grid. This supply is transformed to the plant electrical distribution bus voltage, normally 6600 volts, by one or more system auxiliary transformers. Likewise, the unit auxiliary power is transformed from the output of the plant main generator through the unit auxiliary transformer to the plant electrical distribution voltage. When the plant is shut down, all power is taken from the system auxiliary transformer to provide for plant startup. When the plant is operating and supplying power to the main distribution grid and the unit auxiliary transformer, the plant distribution buses are split and part are supplied by the plant's own generator and the other part are supplied by the system auxiliary transformers. Because plant buses are capable of receiving power from either of two supplies and because automatic transfer of supplies is provided on sensing loss of power, reliability of

power is assured and plant operating safety is increased.

The Engineered Safety Features buses are normally supplied from the system auxiliary transformers. In the event of total loss of auxiliary power from off-site sources, auxiliary power required for safe shutdown will be supplied from physically and electrically independent diesel generators located on the site. Each power source, diesel generator and offsite, up to the point of connection to the engineered safety features system power buses, is physically and electrically independent. Loads important to plant safety are split and diversified between independent engineered safety features system switchgear groups.

Batteries are provided as a source of power for vital loads.

The Electrical System is designed to provide a simple arrangement of buses, requiring a minimum of switching to restore power to a bus in the event that its normal power supply is lost. The basic arrangement of a typical plant electrical system is shown in Figure 11-1.

## **6600-VOLT AND 480-VOLT SYSTEMS**

All of the engineered safety system loads are fed from two 6600-volt engineered safety features buses. The larger auxiliaries such as the service water pumps, centrifugal charging pumps, and safety injection pumps are fed directly from the 6600-volt buses, while the smaller auxiliaries are fed from 480-volt unit substations and motor control centers associated with each 6600-volt engineered safety features bus. The engineered safety features buses are normally energized from system auxiliary transformers.

The system auxiliary transformers and the standby diesel generator constitute the normal and redundant sources of power for the engineered safety features system.

## **DIESEL GENERATORS**

In the event that sources of normal off-site generated auxiliary power are lost, the auxiliaries essential to safe shutdown will be supplied by the Seismic Class 1 diesel-driven generators. The typical connection of the diesel generator standby power to buses of the engineered safety features electrical system is indicated in Figure 11-1. Each diesel generator is designed and installed to provide a reliable source of redundant on-site generated emergency power and is capable of supplying the engineered safety features loads assigned to the engineered safety features electrical system bus which it feeds.

The diesel generators are provided with static-type brushless excitation and field flashing for rapid voltage buildup. The generators are designed to reach rated speed and be ready to begin accepting load within 10 seconds, and be capable of carrying rated load within 30 seconds after receipt of a start signal to the diesel engine. Loads are automatically sequenced on the diesel generator buses over a short period of time to preclude the possibility of overload trip due to simultaneous starting loads.

Automatic synchronizing equipment is provided to permit parallel operation of each diesel with the normal auxiliary power source during testing and exercising periods.

The diesel generators are designed for air-over-piston start and each diesel is provided with redundant starting air compressors and accumu-

lators. The controls for the governor, voltage regulator, generator breaker, and synchronization for each diesel generator are located on physically separated portions of the main control board.

Each diesel engine's fuel oil system, air starting system, and the generator output and excitation systems are equipped with instrumentation to monitor all important parameters and to announce abnormal conditions.

Each diesel generator is provided with a fuel oil day tank and a fuel storage tank. The onsite supply of fuel for each diesel generator is sufficient to allow continuous rated load operation for a minimum of seven days.

## **125-VOLT DC POWER SYSTEM**

The plant is provided with two physically separate and electrically isolated sources of 125-volt dc power, each with its own battery, battery charger and distribution bus. Figure 11-1 includes the normal layout of the 125-volt dc systems. Some plants use four batteries to gain more diversity.

The two batteries are housed in separately ventilated rooms within the auxiliary building and are provided with reinforced battery racks. The battery charger associated with each battery is rated to supply the normal plant dc loads while fully recharging the battery within a twelve-hour period.

The two 125-volt dc batteries are sized to carry the loads for specified time periods. During an actual failure of normal system ac power, the diesel generator power supplies will establish battery charger input within 10 seconds and thereby reduce the drain on the battery system.

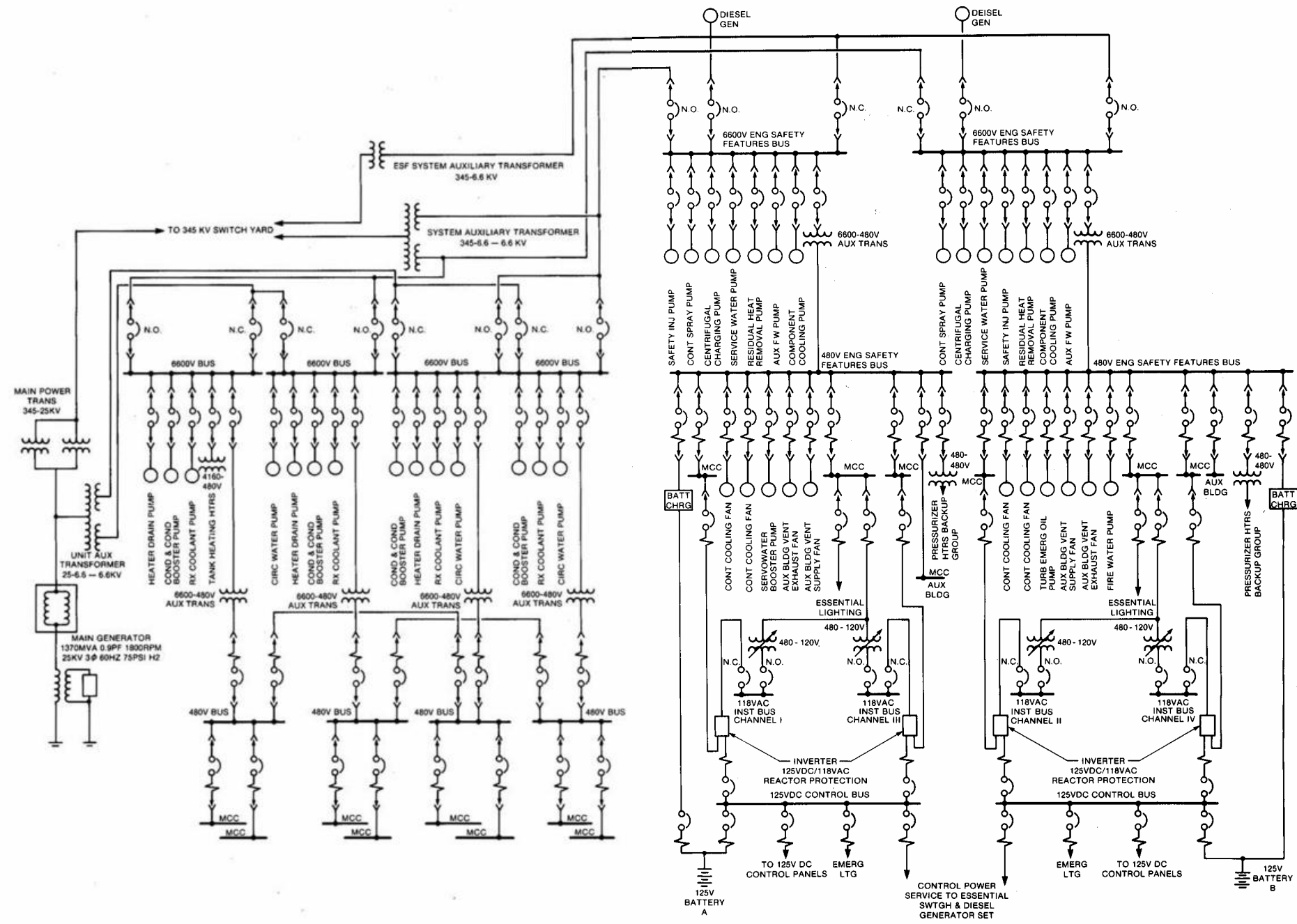

Figure 11-1. Typical PWR Nuclear Power Station Electrical System, One-Line Diagram

During normal operation, the batteries are kept fully charged by the battery chargers. Periodically the voltage is raised for equalization of the charge on the individual battery cells.

### **INVERTER POWER SUPPLY FOR ESSENTIAL SERVICES**

The 118-volt ac instrument power supply is divided into four buses. These four buses provide power for reactor protection and engineered safety features instrumentation and control channels I, II, III, IV, respectively. Four instrument inverters furnish power to the four instrument buses. For diversity, the inverters are equipped with three-phase semiconductor rectifiers so that two input supplies can be used. The rectifier converts three-phase 480 volts ac power from the engineered safety features bus to 130 volts dc for use as the normal inverter input. One hundred and twenty-five volts from

the battery is used to provide a backup supply in the event of loss of three-phase power. The transfer from the normal to the backup supply is automatic.

Each inverter has a 118 volts, single phase, 60 Hz output which feeds its corresponding instrument bus.

Each bus is normally supplied from its respective inverter. An alternate source is available for each instrument bus through its respective 480/120-volt transformer if an inverter is taken out of service. The alternate sources for instrument buses are normally from 480-volt engineered safety features buses through regulating stepdown transformers. The circuit breakers feeding the inverter output and the alternate source to each instrument bus are mechanically interlocked so that only one of the two breakers can be closed at any time.

# **chapter 12**

## **auxiliary cooling systems**

## CIRCULATING WATER SYSTEM

The Circulating Water System serves as the major heat sink for the power plant by providing large amounts of cooling water for the main condensers, the Service Water System, the Fire Protection System, and screen wash system.

Depending on the plant, the source of circulating water may be a river, lake, ocean, or cooling tower. System design will differ significantly depending on the water source. The following describes a system supplied by river water.

Water enters the system through an intake house which is typically divided into intake bays to remove debris. Each bay is equipped with bar grills and two traveling water screens, and serves one circulating water pump and one service water pump. Stop logs are provided to close off the intake bays. These bays may be dewatered individually for maintenance of equipment without completely closing off the circulating water supply to the plant.

Circulating water for each main condenser is supplied by vertical, mixed flow, volute type circulating water pumps. The pumps take suction from their individual intake bays downstream of the traveling screens, and discharge water through motor-operated valves into individual discharge lines which combine into a common discharge line from the main condenser. If required, part of the discharge from the condenser can be recirculated to the intake area for ice melting. Controls, interlocks, and indicators in the main control room are provided to enable the operator to modulate the circulating water pump discharge valves and to vary the number of pumps in service.

## SERVICE WATER SYSTEM

The Service Water System supplies all the cooling water for the plant, including that required for emergency shutdown. Consequently, high reliability and redundancy is required. The component cooling water heat exchangers and other essential equipment coolers are provided with two cooling water supplies by loop headers coming from the main supply header. The nonessential equipment coolers are fed from separate branch headers that can be isolated from the main headers under accident conditions to conserve water.

A typical system design will provide six pumps, three each for essential and nonessential service. The three essential service water pumps for each unit are typically rated at approximately 20,000 gpm (4500 m<sup>3</sup>/hr). The pumps are frequently located in a separate intake house and may take suction from the several independent sources for redundancy of supply. The discharge of the service water pumps passes through two strainers typically with 1/8-inch (0.3 cm) openings to a common header.

The following is a list of typical components supplied by the Service Water System:

- Component cooling heat exchangers
- Containment for ventilation coolers
- Diesel generator coolers
- Control room air conditioning system condensers
- Computer room air conditioning system condensers
- Auxiliary building ventilation system cooling coils



- Penetration pressurization air compressor coolers
- Containment spray pump diesel engine coolers
- Auxiliary building room coolers
- Emergency feedwater pump coolers
- Turbine island loads

Double isolation valves are provided in the loops and single isolation valves in each of the feeds to individual coolers so that the failure of a valve or a single line break will not jeopardize essential cooling.

Normal operation requires two pumps with the third pump serving as a standby. The system pressure is maintained at 55 to 75 psig (4.8 to 6.2 bar) in the main supply header and the third pump automatically starts at a header pressure of 50 psig (4.5 bar).

Cooling water for the essential equipment coolers is provided by the Essential Service Water System, a subsystem of the Service Water System, which under accident conditions can be isolated from that portion of the Service Water System serving the nonessential equipment coolers.

Detection of leakage which might affect system operation is provided by means of installed pressure, temperature, and flow instrumentation and by sump level indicators in the turbine building and auxiliary building sumps. With the exception of the cubicle coolers, system isolation is provided by means of motor-operated valves. This arrangement allows rapid isolation of the portion of the system where leakage is occurring.

## SPENT FUEL POOL COOLING SYSTEM

The Spent Fuel Pool Cooling System is designed to remove residual decay heat generated by irradiated fuel stored in the spent fuel pool. The system also maintains the clarity and purity of the spent fuel cooling water and the refueling water. The system design considers the possibility that during the life of the station, it may become necessary to totally unload a reactor vessel for maintenance or inspection. The design incorporates redundant active components. System piping is arranged so that failure of any pipeline does not drain the spent fuel pool below the top of the stored fuel elements.

The cooling loop in the Spent Fuel Pool Cooling System consists of a pump, heat exchanger, filter, demineralizer, piping, and associated valves and instrumentation. The pump draws water from the pool, circulates it through the heat exchanger and returns it to the pool. Component cooling water cools the heat exchanger.

The clarity and purity of the spent fuel pool water is maintained by passing approximately 100 gpm (23 m<sup>3</sup>/hr) of each loop's flow through a filter and demineralizer. Skimmers are provided to prevent dust and debris from accumulating on the surface of the water.

The refueling water purification pump and filter can be used separately or in conjunction with the spent fuel pool demineralizer to regain refueling canal water clarity after a crud burst. This changeover capability is necessary to prevent loss of time during refueling due to poor visibility. The system is also used to maintain water quality in the refueling water storage tank.



# **chapter 13**

## **fuel handling system**

Spent fuel is handled underwater from the time it leaves the reactor vessel until it is placed in a cask for shipment from the site. The water provides an effective, economical, and transparent radiation shield as well as a reliable medium for decay heat removal. Boric acid is added to the water to ensure subcritical conditions during refueling.

The fuel handling facilities (Figures 13-1 and 13-2) are generally divided into two areas: (1) the refueling cavity and fuel transfer canal, which are flooded only during the refueling shutdown, and (2) the fuel storage pit, which is kept full of water and is always accessible to operating personnel. These two areas are connected by the fuel transfer tube through which an underwater conveyor or fuel transfer system carries the new fuel into the plant (reactor) containment and spent fuel into the fuel handling building.

In the refueling cavity, fuel is removed from the reactor vessel by a refueling machine, transferred through the water, and placed in the fuel transfer system. In the fuel handling building, the fuel is removed from the transfer carriage and placed in storage racks in the fuel storage pit by using a manually operated spent fuel assembly handling tool suspended from an overhead bridge crane. After a sufficient decay period, the spent fuel can be removed from the fuel racks and loaded into a shipping cask for removal from the site.

New fuel assemblies normally arrive at the site shortly before refueling is to commence. Following site receipt inspection to check for any possible shipping damage, the new assemblies are lowered into the fuel storage pit by means of

the new fuel elevator and are placed underwater in the storage racks. During the refueling operation, the new assemblies are transported from their storage locations in the pit to the fuel transfer system by means of the fuel handling machine and the spent fuel handling tool.

## FUEL HANDLING FACILITIES

Fuel handling facilities consist of a refueling cavity and fuel storage pit as previously defined.

### Refueling Cavity

The refueling cavity is a reinforced concrete structure. When filled with borated water for refueling, it forms a pool above the reactor. The cavity is filled to a depth of approximately 24 feet (731 cm) of water when a fuel assembly is being transferred between the reactor and the fuel transfer system. This limits radiation at the surface of the water to acceptable levels during those brief periods. Radiation levels as a function of water depth in the refueling cavity for a 12-foot (366 cm) active fuel assembly are given in Table 13-1.

The reactor vessel flange is permanently sealed to the refueling cavity floor by means of a welded stainless steel seal ring (Figure 13-3). This permanent concrete-to-vessel cavity seal prevents leakage of refueling water from the cavity. Cooling air ventilation for the reactor vessel annulus is routed through the exit ductwork located below the seal.

The refueling cavity is large enough to provide underwater storage space for the reactor upper and lower internals and for miscellaneous refueling tools.

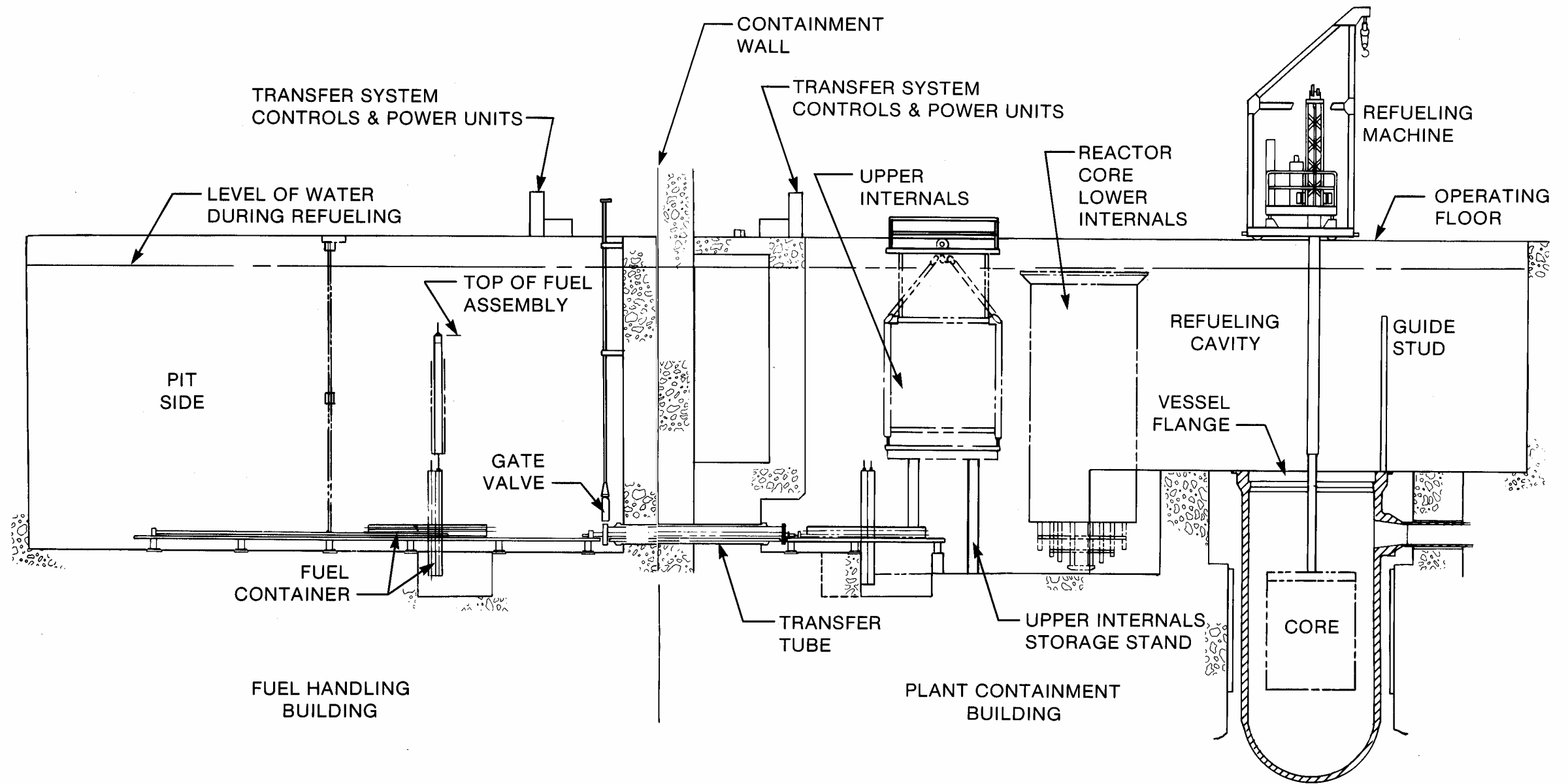

Figure 13-1. Fuel Handling Layout

LEGEND:

- |  |   |
|--|---|
| 1. CONTAINMENT   | 8. UPPER INTERNALS STRUCTURE-<br>(ON STORAGE STAND) |
| 2. FUEL BUILDING   | 9. LOWER INTERNALS<br>STORAGE STAND                 |
| 3. REFUELING CAVITY                                      | 10. REACTOR VESSEL                                  |
| 4. FUEL TRANSFER CANAL                                   | 11. REACTOR CORE                                    |
| 5. OPERATING DECK  | 12. REFUELING MACHINE                               |
| 6. CONTAINMENT POLAR CRANE                               | 13. ROD CLUSTER CONTROL<br>CHANGING FIXTURE         |
| 7. REACTOR VESSEL HEAD<br>ASSEMBLY (ON STORAGE<br>STAND) | 14. FUEL TRANSFER TUBE                              |
|  | 15. FUEL HANDLING MACHINE<br>AND HOIST              |
|  | 16. FUEL STORAGE RACKS                              |
|  | 17. SPENT FUEL CASK<br>LOADING AREA                 |

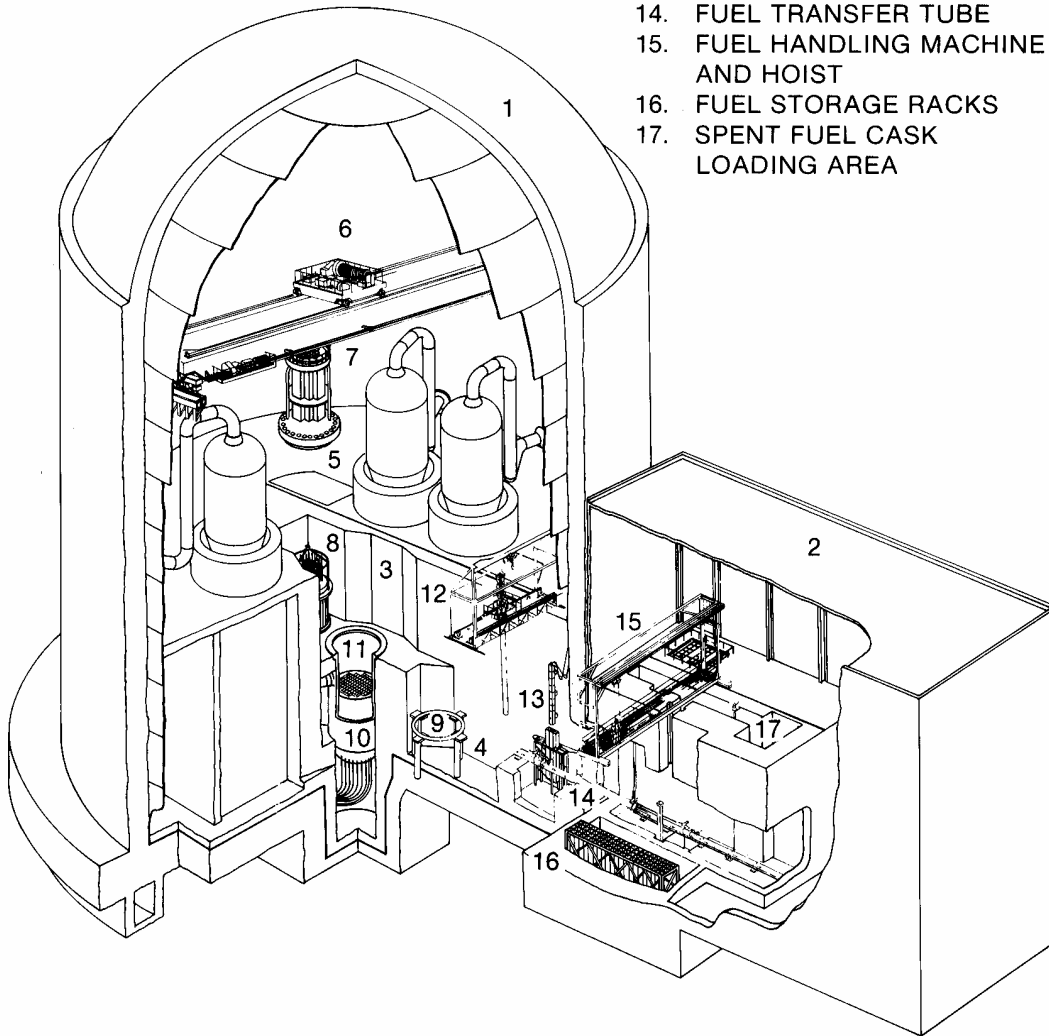
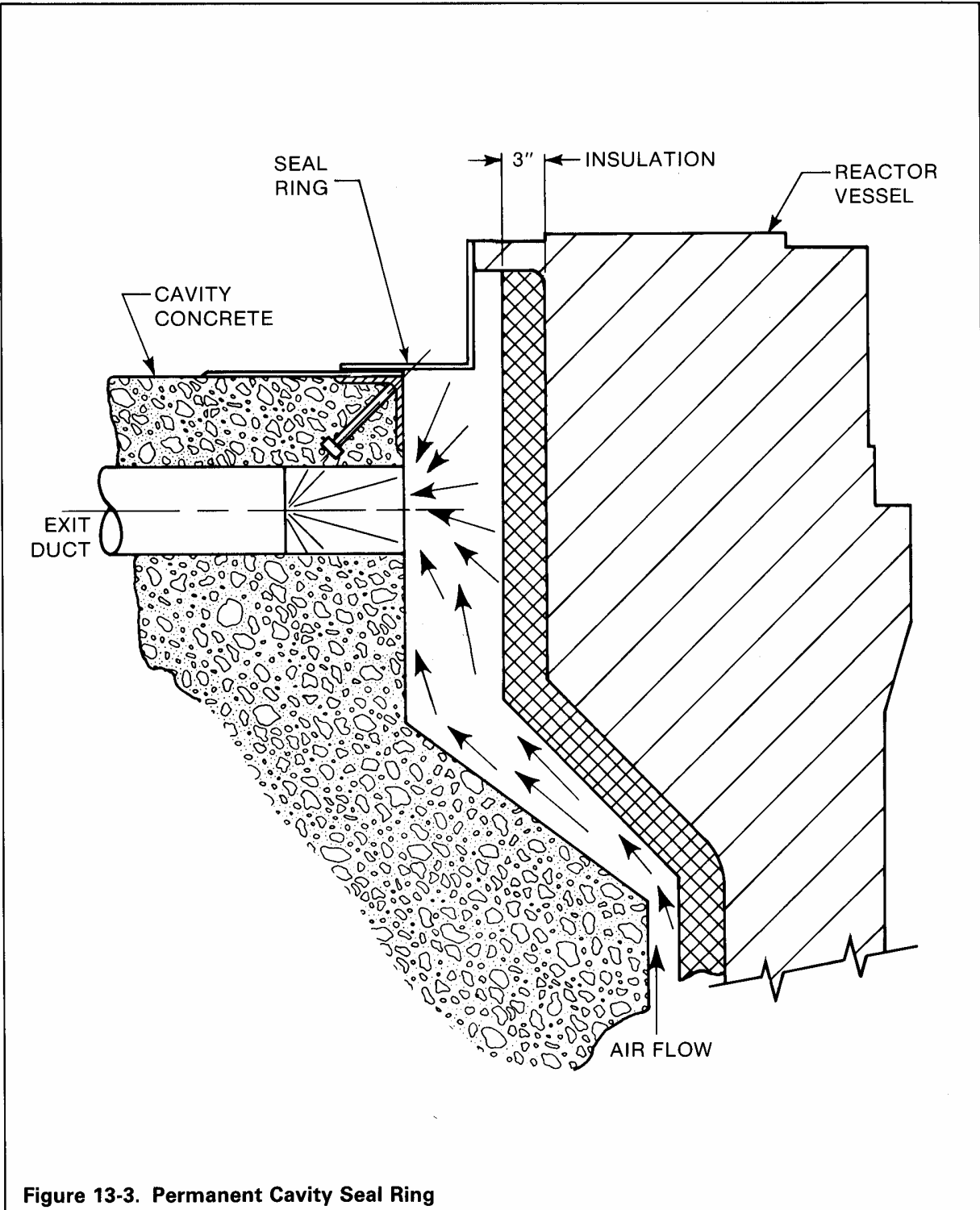

Figure 13-2. Typical Fuel Handling Arrangement



## Fuel Transfer Canal

The fuel transfer canal is a passageway that extends from the refueling cavity to the inside surface of the reactor containment. The canal is formed by concrete shielding walls extending upward to the same elevation as the refueling cavity. A portion of the floor of the canal is at a lower elevation than the refueling cavity. This provides the extra depth needed for the fuel transfer system upending device and the rod cluster control changing fixture located in the canal. The transfer tube, which connects the fuel transfer canal to the fuel handling building, is sealed at both ends except during refueling.

## Fuel Storage Pit

The fuel storage pit provides for the underwater storage of spent fuel assemblies and new fuel assemblies in the fuel storage racks. It is constructed of reinforced concrete, and the entire

interior face is lined with stainless steel plate. Because there are no gravity drains in the pit, it cannot be drained accidentally. Cooling to remove residual decay heat from the spent fuel is provided by a spent fuel pit cooling and cleanup system.

Spent and new fuel assemblies are handled manually by a spent fuel assembly handling tool suspended from an overhead hoist and manipulated by an operator standing on a movable bridge over the pit.

Fuel assembly storage racks to accommodate a minimum of 1-1/3 times the number of assemblies in a core are located on the pit floor. Fuel assemblies are placed in vertical cells, continuously grouped in parallel rows on 14-inch (35.6 cm) centers in both directions (10-1/4 inch (26 cm) center line spacing is achieved by using storage cells incorporating a neutron absorber). The racks are designed to preclude insertion of fuel assemblies in other than the prescribed locations, thereby maintaining the necessary spacing between assemblies. The racks thus provide a subcritical geometric array. Borated water is used to fill the pit to a concentration matching that used in the refueling cavity during refueling, and to a depth sufficient to allow transfer of the fuel assemblies while providing adequate shield water cover.

## Decontamination Facilities

Equipment and cask cleaning areas are located adjacent to the spent fuel storage pit. In the equipment area, fuel handling equipment and other tools can be cleaned and decontaminated. In the cask cleaning area, the outside surfaces of the cask are decontaminated by using steam, water, detergent solutions, and manual

TABLE 13-1 RADIATION LEVELS AS A FUNCTION OF WATER DEPTH ABOVE FUEL ASSEMBLY	
Water Depth Above Top of Fuel Assembly*	Radiation Level (mr/hr)
9' 6" (289.6 cm)	2.5
9' 0" (274.3 cm)	5.2
8' 6" (259.1 cm)	10.9
8' 0" (243.8 cm)	23.0
7' 6" (228.6 cm)	47.0
7' 0" (213.4 cm)	99.0
6' 6" (198.1 cm)	206.0

\* Distance from top of fuel assembly to top of active fuel length is one foot.

scrubbing to the extent required. When determined to be clean, the cask is removed by crane for loading onto a truck or railroad car.

## **REFUELING EQUIPMENT**

The fuel handling equipment consists of a number of tools used to open and close the reactor and to move fuel from one location to another. These tools are described in the following paragraphs.

### **Reactor Vessel Head Lifting Device**

The reactor vessel head lifting device consists of a welded and bolted structural steel frame with suitable rigging to enable the reactor containment crane to lift the head and store it during refueling operations. The lifting device is permanently attached to the reactor vessel head. Attached to the head lifting device are the monorail and hoists for the reactor vessel stud tensioners.

### **Reactor Internals Lifting Device**

The reactor internals lifting device is a structural frame suspended from the overhead crane. The frame is lowered onto the top support plate of the upper internals, and is connected to the support plate by three breech-lock-type connectors having long tubes extending up to an operating platform on the lifting device. Bushings on the frame engage guide studs in the vessel flange to provide precise guidance during removal and replacement of the internals package. The internals lifting device is also used to remove the lower internals structure approximately once every 10 years.

### **Refueling Machine**

The refueling machine transfers fuel assemblies within the core and between the core and the

fuel transfer system conveyor carriage. It is a rectilinear bridge and trolley crane with a stationary vertical mast extending down into the refueling water. The bridge spans the refueling cavity and runs on rails set into the floor along the edge of the refueling cavity. The bridge and trolley motions are used to position the vertical mast over a fuel assembly in the core.

A movable mast with a pneumatic gripper on the end is lowered down from inside the stationary mast to grip the fuel assembly. The movable mast is long enough so that the upper end is still contained in the stationary mast when the gripper end contacts the fuel. A winch mounted on the trolley raises the gripper and fuel assembly up into the stationary mast. Fuel is transported by the mast to its new position.

All refueling machine controls are mounted on a console on the trolley. The bridge is positioned on a coordinate system laid out on the bridge and trolley rails. The electrical readout system on the console indicates the position of the bridge. The trolley is positioned on the bridge structure with the aid of a scale, which is read directly by the operator at the console.

The refueling machine is supplied with an electrical monorail hoist mounted above the bridge walkway for use with long-handled manual tools. The hoist is suspended from a beam running the length of the bridge.

The drives for the bridge, trolley, and main boom winch are variable speed, including a separate inching control on the winch. The main boom and trolley drives are variable to 20 feet per minute, and the bridge drive is variable to 40 feet per minute. The overhead monorail hoist is driven at two speeds, 7 and 22 feet per minute.



Electrical interlocks and limit switches on the bridge and trolley drives protect the equipment. In an emergency, the bridge, trolley, and winch can be operated manually by using a handwheel on the motor shaft.

The suspended weight on the gripper tool is monitored by an electrical load cell indicator mounted on the control console. A load in excess of 110 percent of a fuel assembly weight automatically stops the winch drive from moving in the up direction. The gripper is interlocked through a weight-sensing device and also a mechanical spring lock so that it cannot be opened accidentally when supporting a fuel assembly. Numerous other safety features are incorporated in the manipulator crane design.

Suitable restraints are provided between the bridge and trolley structures and their respective rails to prevent derailing due to the maximum potential earthquake. The refueling machine is designed to prevent disengagement of a fuel assembly from the gripper under the maximum potential earthquake.

### **Fuel Handling Machine**

The fuel handling machine is a wheel mounted bridge that spans the fuel storage pit. It carries an electric monorail hoist on an overhead structure. Fuel assemblies are moved within the fuel pit by means of long-handled tools suspended from the hoist. Both the bridge and the hoist drives can operate at two speeds. The hoist travel and tool length are designed to limit the maximum lift of a fuel assembly to a safe shielding depth.

### **Rod Cluster Control Changing Fixture**

The rod cluster control (RCC) changing fixture is mounted on the fuel transfer canal wall and is

used for periodic RCC element inspections and for transfer of RCC elements from one fuel assembly to another. The fixture consists of two main components: a guide tube mounted to the wall for containing and guiding the RCC element, and a wheel-mounted carriage for holding the fuel assemblies and positioning fuel assemblies under the guide tube. The guide tube contains a pneumatic gripper on a winch that grips the RCC element and lifts it out of a fuel assembly. By repositioning the carriage, a new fuel assembly is brought under the guide tube and the gripper lowers and releases the RCC element. The refueling machine loads and removes the fuel assemblies into and from the carriage.

### **Upper Internals Storage Stand**

The upper internals storage stand is a structural stainless steel fixture mounted to the floor of the refueling cavity and is used to support the upper internals structure from its top flange when removed from the reactor vessel. For alignment purposes, guide studs are provided to mate with the bushings on the internals lifting rig. During refueling, the stand is underwater.

### **Reactor Vessel Stud Tensioner**

Stud tensioners are employed to release and secure the head closure joint at every refueling. The stud tensioner is a hydraulically operated device that uses oil as the working fluid. The device permits preloading and unloading of the reactor vessel closure studs at cold shutdown conditions. Three tensioners are provided and are applied simultaneously to three studs located 120 degrees apart. A single hydraulic pumping unit operates the tensioners which are hydraulically connected in series. The studs are tensioned to their operational load in three steps to prevent



high stresses in the flange region and unequal loadings in the studs. Relief valves on each tensioner prevent overtensioning of the studs due to excessive pressure; micrometers are provided to measure stud elongation after tensioning.

### **Stud Tensioner Handling Device**

The stud tensioner handling device is used to suspend the stud tensioner from the support structure on the reactor vessel head lifting rig during installation or removal of the reactor vessel studs.

### **Fuel Transfer System**

The fuel transfer system incorporates an underwater conveyor car that runs on tracks extending from the fuel transfer canal through the transfer tube in the containment wall and into the fuel building. The car is driven by a pusher arm connected to two continuous roller chains. The roller chains are driven by an electric motor mounted near the operating floor of the fuel storage pit and connected to the chain drive sprockets by a vertical drive shaft.

Two center-pivoted fuel assembly containers (Figure 13-4) are attached to the transfer car by means of the pivot. The containers and car travel as a single unit, and the unit is positioned against a mechanical stop. The containers are raised against another mechanical stop by a lifting arm attached to one of two stationary water hydraulic cylinders. The two hydraulic cylinders, one located in the refueling cavity and the other in the fuel building, are operated by a hydraulic power unit mounted at the operating deck level. The power unit is a positive displacement pump driven by an electric motor.

A demineralized water reservoir, mounted in the same power package, supplies replacement water for any leakage passed through the graphitar seals. The reservoir is connected to the plant demineralized water supply through a float valve for automatic refilling as needed. A separate power unit package is supplied for each of the two hydraulic cylinders.

The conveyor car container accepts a fuel assembly in the vertical position. It is rotated to a horizontal position for passage through the fuel transfer tube and is then rotated to a vertical position for unloading. The unloading operation is the same in both the fuel building and the containment transfer canals.

During plant operation the conveyor car is stored in the fuel building. A gate valve in the transfer tube on the fuel building end is closed to seal the reactor containment. The terminus of the tube inside the containment is sealed by a blind flange.

### **Control Rod Drive Shaft Unlatching Tool**

The control rod drive shafts are disconnected and reconnected to the rod cluster control assemblies by means of the control rod drive shaft unlatching tool. This tool is suspended from the auxiliary hoist on the refueling machine and is operated from the bridge. The latching mechanism is pneumatically operated. All drive shafts are removed as a unit with the reactor vessel upper internals.

### **Spent Fuel Assembly Handling Tool**

This tool is used to handle new and spent fuel in the fuel storage pit. It consists of a gripping device on the end of a long tube suspended

from the fuel pit auxiliary hoist. An operator on the fuel handling machine bridge guides and operates the tool.

### Rod Cluster Control Thimble Plug Handling Tool

This long-handled, manually operated tool is used in the fuel transfer canal to remove and replace thimble plugs in fuel assemblies. When an RCC element is being transferred from one fuel assembly to another, a thimble plug is inserted in the fuel assembly from which the RCC was removed.

### Primary Source Rod Insertion Guide

This is a disposable guide used to install the primary startup neutron sources in the fuel assembly. Because the primary source is

radioactive, it must be handled remotely. The guide is placed in the fuel assembly top nozzle to guide the source rod into the proper thimble.

### Burnable Poison Rod Assembly Handling Tool

This long-handled tool is used to transfer burnable poison rod assemblies between two fuel assemblies or a fuel assembly and inserts in fuel storage racks.

### Irradiation Surveillance Capsule Handling Tool

This long-handled tool is used to reach down through openings in the reactor lower internals flange to remove the irradiation surveillance capsules from holders mounted on the neutron pads.

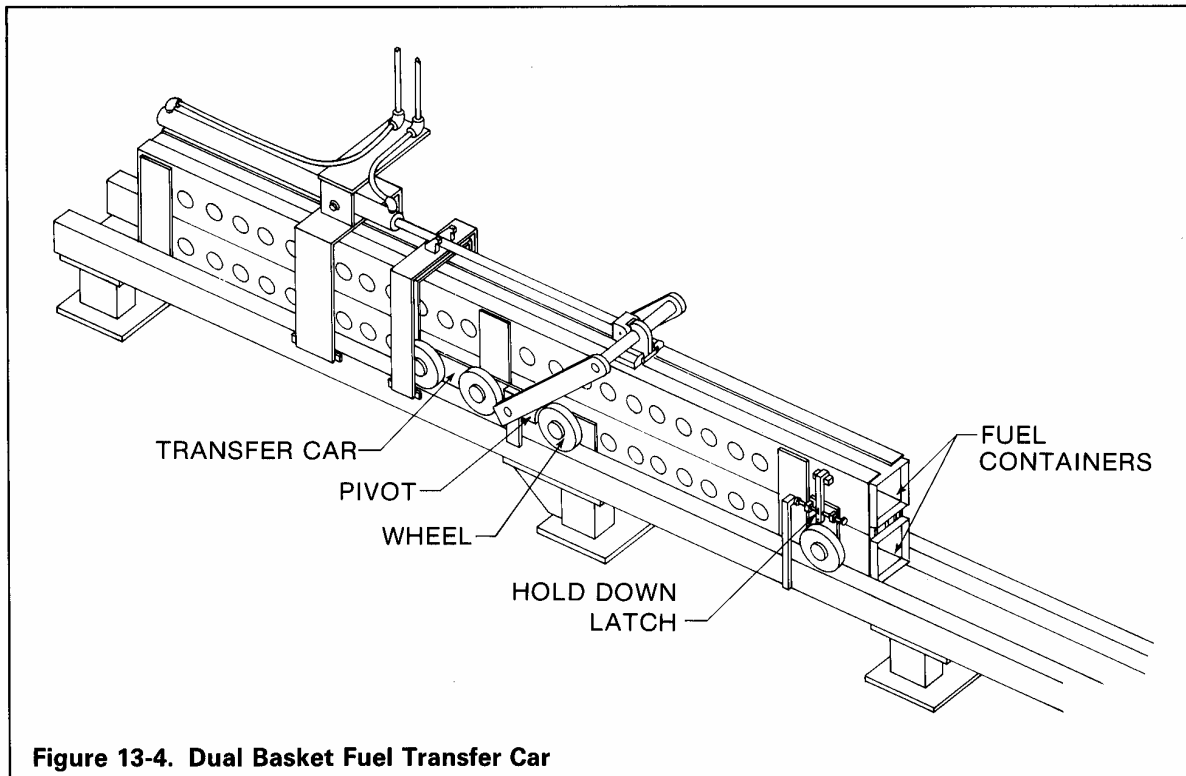

### **New Rod Control Cluster Handling Tool**

This short-handled tool is used for the handling of new unirradiated rod control clusters in the fuel building and to facilitate inspection and insertion of new rod control clusters into new fuel elements.

### **New Fuel Assembly Handling Fixture**

This short-handled tool is used to handle new fuel on the operating deck of the fuel building, to remove the new fuel from the shipping container, and to facilitate inspection and loading of fuel into the new fuel elevator.

### **Control Rod Drive Shaft Handling Fixture**

This fixture is used during construction of the plant for initial installation of the control rod drive shafts.

### **Stud Hole Plugs**

Unthreaded side-sealing stainless steel stud hole plugs are used to prevent refueling water from entering the reactor vessel closure stud holes. The expanding seal plug is placed into the counterbored upper portion of the stud hole with a handling tool. The plug is then mechanically expanded to force the dual elastomer seal rings against the counterbored stud hole wall to make the watertight seal. This sealing method eliminates the potential for galling of the stud hole threads.

### **Stud Hole Plug Handling Fixture**

This is a small tool used to insert the stud hole plugs into the reactor vessel stud holes following stud removal.

### **Guide Studs**

Three guide studs are inserted into the reactor vessel flange in vacated stud holes during refueling. The studs guide the closure head off and onto the vessel and the internals into and out of the vessel.

### **Load Cell**

A load cell is inserted between the polar crane hook and the reactor internals lifting rig and between the polar crane hook and the head lifting rig to monitor the lifting force during removal of the internals and the head.

### **Crane Scales**

The crane scales are load-measuring devices used to monitor the lifting forces of long-handled tools during refueling operations.

### **Refueling Machine Load Test Fixture**

The load test fixture is a stainless steel mockup of the fuel assembly top nozzle anchored to the refueling cavity floor. The test fixture is used to check out the refueling machine prior to refueling.

### **New Fuel Elevator and Winch**

The new fuel elevator and winch are used to lower new fuel assemblies to the bottom of the spent fuel pit, either for temporary storage in the fuel racks or placement in the transfer system for transfer to the reactor. The elevator is a box-shaped assembly with its top open and sized to house one fuel assembly.

### **Underwater Lights**

An assembly of cable, cable reel, and underwater light fixtures is provided for illumination of

the underwater working area. The cable reels are supported on the refueling machine or fuel handling machine.

### **Irradiation Tube End Plug Seating Jack**

The seating jack consists of a rectangular frame, a hydraulic cylinder which threads into the frame, and a hand pump connected to the cylinder by a flexible hose. When the cylinder is energized, the jack applies downward force on the irradiation capsule to seat the capsule end plug in the specimen guide adapter.

## **REFUELING OPERATION**

The reactor is generally refueled by plant operating personnel. To perform the fuel handling operation, one supervisor and six technicians are necessary for each shift. Maintenance personnel are also employed to provide labor support during various phases of the refueling operation. This manpower requirement only applies to the fuel handling operation. Other plant and maintenance work in progress will require additional personnel. Licensed operators must also be in attendance in the control room, and health physics coverage is required.

Detailed instructions are made available for use by refueling personnel. These instructions, safety limits and conditions, and the design of the fuel handling equipment incorporate built-in interlocks and safety measures.

Prior to initial fueling, preoperational checkouts of the fuel handling equipment are performed to verify the proper performance of the fuel handling equipment and to familiarize plant operating personnel with operation of the equipment. A dummy fuel assembly and RCC are utilized for this purpose.

Immediately prior to each refueling operation, the equipment is inspected for satisfactory operating condition. Certain components, such as the fuel transfer car and refueling machine, are operated at this time to test their performance prior to moving irradiated fuel.

Direct communication between the control room and the refueling machine should be available whenever changes occur in core geometry. This provision allows the control room operator to inform the refueling machine operator of any impending unsafe condition detected from the main control board indicators during fuel movement.

The refueling operation is divided into five major phases: preparation, reactor disassembly, fuel handling, reactor reassembly, and preoperational checks, tests, and startup. The estimated refueling manhours required are listed in Table 13-2. A general description of a typical refueling operation through the five phases is given in the following paragraphs.

### **Phase I – Preparation**

- (1) The reactor is shut down and cooled to ambient conditions.
- (2) A radiation survey is made, and the containment is entered.
- (3) The fuel transfer equipment and refueling machine are checked out.

### **Phase II – Reactor Disassembly**

- (1) The control rod drive mechanism cooling fans and air ducts are disconnected and moved to storage.\*

---

\* These operations are eliminated or simplified if the integrated reactor vessel head package is used.

**TABLE 13-2  
MAJOR REFUELING OPERATIONS  
(ESTIMATE OF TIME AND MANHOURS)**

Operation	Duration Estimated (Hours)	Estimated Manhours
Remove CRDM fans and cooling ducts **	5	20
Remove missile shield **	2	8
Remove RV head insulation	4	16
Remove seismic tie rods	2	8
Disconnect CRDM cables **	6	24
Disconnect thermocouples	4	8
Remove cable tray and missile shield ** support beams	6	18
Detension and remove studs **	31 (9)*	124 (36)*
Install guide studs and plugs	2	8
Install head lift rig **	2	6
Remove RV head assembly	4	8
Disconnect control rod drive shafts	6	18
Remove upper internals	4	16
Fuel shuffle	83	664
Reconnect control rod drive shafts	11	44
Replace RV head assembly	4	16
Remove head lift rig	2	4
Remove guide studs and plugs	2	4
Install and tension studs	45 (11)*	180 (44)*
Connect cable tray and missile ** shield support beams	4	16
Connect thermocouples	10	20
Connect CRDM cables **	10	20
Connect seismic tie rods	4	16
Install RV head insulation	4	16
Install missile shield **	4	16
Install CRDM fans and duct work**	5	30
Totals	266	1328

\* Improved Head Closure System values

\*\* These operations are eliminated or simplified if the integrated reactor vessel head package is used.

- (2) Control rod drive mechanism missile shield is removed and stored.\*
- (3) Reactor vessel head insulation is removed.\*
- (4) Control rod drive mechanism cables are disconnected.
- (5) Upper instrumentation thermocouple leads are disconnected. The thermocouple column protective sleeve is installed over the top of the support column.
- (6) Seismic support tie bars, cable tray\* assembly, and missile shield support beams are removed.
- (7) In-core instrumentation thimble guides are disconnected at the seal table and extracted.
- (8) Reactor vessel head nuts are loosened using the stud tensioners.
- (9) Reactor vessel head studs and nuts are removed and stored.
- (10) Guide studs are installed in three stud holes. The remainder of the stud holes are plugged.
- (11) Vessel head lifting rig tripod is installed\* while final preparations are made for underwater lights, tools, and fuel transfer system. The blind flange of the tube enclosing the fuel transfer tube is removed.
- (12) Reactor vessel head is unseated and raised by the plant crane.
- (13) Reactor cavity is filled with borated water to the vessel flange.
- (14) Head is slowly lifted while water is pumped into the cavity. The water level and vessel head are raised simultaneously, keeping the water level just below the head.
- (15) Reactor vessel head is removed to a dry storage area.
- (16) Control rod drive shafts are unlatched using the drive shaft unlatching tool. A check is made to ensure that the drive shafts are fully disconnected from the RCC. The control rod drive shafts remain with the reactor vessel upper internals.
- (17) Reactor internals lifting rig is lowered into position over the guide studs by the plant crane. The rig is then secured to the support plate of the upper internals structure.
- (18) Reactor vessel upper internals and control rod cluster drive shafts are lifted out of the vessel and stored in the underwater storage stand in the refueling cavity.
- (19) Fuel assemblies and control rod clusters are now free from obstructions and are ready to be removed from the reactor core.

### Phase III – Fuel Handling

- (1) Refueling sequence is started with the refueling machine.
- (2) Machine is positioned over a fuel assembly in the most depleted region of the core.
- (3) Fuel assembly is lifted to a predetermined height sufficient to clear the reactor vessel and still have sufficient water covering it to prevent any radiation hazard to the operating personnel.
- (4) Refueling machine is moved to line up the fuel assembly with the fuel transfer carriage.
- (5) Fuel transfer carriage is moved into the fuel transfer canal from the fuel building. In one of the containers is a fresh fuel assembly; the second container is empty.
- (6) Fuel assembly containers are tipped upright by the hydraulically operated lifting arm.
- (7) Refueling machine loads the spent fuel assembly into the empty fuel assembly

---

\* These operations are eliminated or simplified if the integrated reactor vessel head package is used.

- container of the carriage and then unloads the fresh fuel assembly and returns to the core.
- (8) Containers are lowered to the horizontal position by the lifting arm.
  - (9) Carriage is moved through the fuel transfer tube to the fuel building.
  - (10) Fuel assembly containers are tipped upright. A new assembly brought from its storage location is loaded into the empty fuel assembly container.
  - (11) Spent fuel assembly is unloaded by the long-handled tool attached to the fuel handling machine hoist.
  - (12) Fuel assembly container is lowered to the horizontal position and the conveyor car is moved back into the containment.
  - (13) Meanwhile, the refueling machine has moved another spent fuel assembly with an RCC assembly into the RCC change fixture.
  - (14) Refueling machine takes the fresh fuel assembly, which is to receive an RCC, from the fuel transfer basket and places it in the RCC change fixture.
  - (15) RCC change fixture removes the RCC assembly from the spent fuel.
  - (16) RCC assembly is placed in the fresh fuel assembly.
  - (17) Spent fuel assembly is removed from the RCC change fixture and placed in one of the fuel assembly containers.
  - (18) Fresh fuel assembly with RCC assembly is taken by the refueling machine to the core.
  - (19) Fuel assembly containers are lowered to the horizontal position by the lifting arm.
  - (20) Carriage is moved through the fuel transfer tube to the fuel building to continue the fueling process.
  - (21) Partially spent fuel assemblies are moved from one region to another region of the reactor core.

- (22) New fuel assemblies are loaded into the proper region of the core.
- (23) Applicable RCC and thimble plug shuffling is done with the manipulator crane, RCC changing fixture, and thimble plug handling tool.

#### **Phase IV – Reactor Reassembly**

- (1) Fuel transfer tube gate valve is closed.
- (2) Old O-rings are removed from the reactor vessel head, the grooves cleaned, and new rings installed.
- (3) Reactor vessel upper internals are placed in the vessel by the polar crane. The reactor vessel internals lifting rig is removed and stored.
- (4) Control rod drive shafts are latched to the rod cluster control assemblies.
- (5) Reactor vessel head is picked up by the plant crane and positioned over the reactor vessel.
- (6) Reactor vessel head is slowly lowered. Simultaneously, the water level is kept just below the head.
- (7) When the head is about 1 foot above the vessel flange, the refueling cavity is completely drained and the flange surface is cleaned.
- (8) Reactor vessel head is seated.
- (9) Reactor vessel head lifting rig tripod is removed\* and the cavity is decontaminated.
- (10) Stud hole plugs and guide studs are removed.
- (11) Head studs and nuts are installed and torqued.

---

\* The integrated reactor vessel head package eliminates or simplifies these operations.



- (12) Blind flange is installed to close the containment side of the fuel transfer tube.
- (13) Vessel head insulation and instrumentation are installed.\*
- (14) Missile shield support beams and cable trays are installed.\*
- (15) Control rod drive mechanisms are checked out for proper operation.
- (16) Control rod drive missile shield is installed.\*
- (17) Electrical leads and cooling air ducts are installed.\*
- (18) In-core instrumentation thimble guides are inserted into the core and sealed at the seal table.
- (19) Hydrostatic test is performed on the reactor vessel.

### **Phase V – Preoperational Checks, Tests, and Startup**

Preoperational physics tests are performed as necessary.

### **NEW FUEL HANDLING**

New fuel handling involves (1) unloading the new fuel shipping containers from the transport vehicle and storing the containers in the fuel building, (2) removing new fuel from the shipping containers, (3) inspecting and storing the new fuel, and (4) maintaining security of the new fuel. A typical fuel shipment on a flat bed trailer consists of six containers; a piggyback rail shipment would carry two such flat bed trailers. Two fuel assemblies are shipped per container. They are secured to a shock-mounted strong-back, located inside the container, and are shipped in the horizontal position.

---

\* The integrated reactor vessel head package eliminates or simplifies these operations.

The new fuel elevator, located on the side of the spent fuel canal, is used to lower new fuel assemblies down into the canal. Following receipt inspection, a new fuel assembly is placed in the elevator using a short-handled tool suspended from a hoist. The elevator is then lowered into the canal where the spent fuel handling tool is attached and the new fuel assembly is transferred to a storage cell where it remains until transferred into the reactor containment.

### **Common Refueling Equipment Modifications**

The refueling operation contributes significantly to the radiation exposure of plant personnel and to plant downtime. For these reasons, some utilities have elected to add capital equipment to achieve operational advantages. The four most common additions are the improved reactor vessel head closure system, the integrated reactor vessel head package, the quick-opening transfer tube closure, and the SIGMA manipulator crane.

### **Improved Reactor Vessel Head Closure System**

The improved pressure vessel head closure system significantly reduces the time required to tension/detension and remove/insert the vessel studs during the refueling operation.

The system includes:

- A quick-acting stud tensioning device with a high-capacity hydraulic control cart to speed up the tensioning operation.
- An improved radial arm hoist to position studs and stud tensioners radially and circumferentially.



- A motor-driven stud removal tool.
- Stud support collars to permit lifting of the studs with the head.

### **Integrated Reactor Vessel Head Package**

The integrated reactor vessel head package is a system that combines the head lifting rig, seismic platform, lift columns, reactor vessel missile shield, control rod drive mechanism (CRDM), forced-air cooling system, and electrical and instrumentation cable routing into a single, efficient design package. This system eliminates removal and replacement of the CRDM cooling system, the CRDM missile shield, and the head lifting rig.

### **Quick-Opening Transfer Tube Closure**

The fuel transfer system utilizes a blind flange closure on the reactor containment end of the transfer tube. This flange is attached to the tube by bolts which must be removed and reinstalled for each refueling.

A quick-opening transfer tube closure was developed to reduce both the time needed for this task and radiation exposure. This quick-opening transfer tube closure is flange locked and held in place by toggle mechanisms actuating a series of radial latches. It replaces the old-style blind flange. The assembly is held by a davit for pivoting and raising when the transfer tube is being opened.

### **SIGMA MANIPULATOR CRANE**

When thimble plugs and rod cluster control assemblies (RCCAs) are changed from one fuel assembly to another with a standard refueling machine, the fuel assemblies are placed in the fuel transfer system upender or rod cluster

control (RCC) change fixture to facilitate removal/insertion with a long tool. By providing the capability for the handling of thimble plugs and RCCAs in the mast, Westinghouse has eliminated the need for the machine to travel to and from the fuel transfer system upender or the RCC change fixture, the long-handled tool operations, and the need for fuel retrieval.

### **REACTOR CAVITY FILTRATION SYSTEM**

During refueling, the reactor cavity water often becomes turbid, which makes it difficult to observe the removal and replacement of fuel assemblies. This turbidity is caused by the dislodgment of particles when the cavity is flooded. The Reactor Cavity Filtration System was developed to counteract this problem. The system is effective in clarifying cavity water overnight and maintaining clarity for the duration of the refueling operation.

The Reactor Cavity Filtration System consists basically of a stainless steel pump, its motor, and four stainless steel filter housings.

The pump is a 250-gpm (16 l/sec), centrifugal, self-priming stainless steel model with special seals which are resistant to boric acid attack and powered by a 7.5-hp electric motor. The pump and motor are mounted on a common base with the inlet and outlet having flanged connections. The pump and motor unit is easily transportable through the personnel access hatch.

The filter unit consists of four filter housings, valves, and associated piping mounted on a common base. The layout of this assembly is such that each filter housing can be isolated from the system for filter cartridge replacement while the system remains in operation.

# **chapter 14**

## **waste processing systems**

The Waste Processing Systems process liquid, gaseous, and solid plant effluents during power operation and plant shutdowns. The systems consist of the Liquid Waste Processing System, the Waste Gas Processing System, and the Solid Waste Processing Systems.

The Liquid Waste Processing System is designed to collect, process, monitor, and recycle for reuse the liquid waste effluents generated during various plant operations. The Waste Gas Processing System stores waste gases for fission product decay and eventual release. Wastes which cannot be recycled and must be disposed of safely are volume reduced and packaged for disposal by the Solid Waste Systems.

### **LIQUID WASTE PROCESSING SYSTEM**

The Liquid Waste Processing System (Figure 14-1) is provided for use in the processing and handling of radioactive wastes generated during various modes of plant operation. The system is designed to receive, segregate, process, monitor, and recycle for reuse all primary system waste effluents. The system is designed so that tritium-containing water can be segregated from non-tritium-containing water and includes a separate laundry waste treatment system, thus allowing for easy tritium control. In addition, provisions are made to handle spent regenerant chemicals from condensate polishers and waste from decontamination of spent fuel shipping casks.

The system consists of several waste holdup and collection tanks, corresponding pumps, waste evaporators, demineralizers, filters, monitors, and associated piping. Liquid wastes from floor drains, laundry, hot showers, laboratory rinses, equipment drains, and the like are collected in their respective holdup tanks.

After collection, some wastes are processed for disposal; most are processed through the waste evaporators or the reverse-osmosis package. Sample analysis is performed and the wastes are either recycled for reuse or disposed of safely.

The system design incorporates features specifically aimed at minimizing the environmental impact of plant operation. In addition, the design provides adequate processing capacity to accommodate unforeseen occurrences of high liquid waste leakage. Sufficient capacity, redundancy, and flexibility provide a wide range of operability.

### **GASEOUS WASTE PROCESSING SYSTEM**

The Gaseous Waste Processing System (Figure 14-2) receives noble fission gases which have been stripped from the reactor coolant through the use of hydrogen gas as a carrier. The stripping of the fission gases by hydrogen reduces the fission gas concentration in the reactor coolant to a low residual level. This minimizes the release of radioactive gases during maintenance operations on the Reactor Coolant System (RCS) or through unavoidable equipment leaks in the RCS.

The system consists of a waste gas dryer, charcoal adsorption beds, guard beds, a charcoal fines filter, a surge tank, and recycle line compressors. The hydrogen carrier gas from the volume control tank (part of the Chemical and Volume Control System) first enters the refrigerated waste gas dryer which cools the hydrogen purge stream and condenses and removes the water vapor. The dried gas then flows to the guard beds which protect the charcoal adsorption beds from water

contamination. The flow is then routed through the charcoal adsorption tanks where the noble fission gases contained in the waste stream are absorbed. Xenon-133 is delayed for a period of 60 days, after which time the concentration of xenon in the exiting hydrogen stream is negligible. The system is designed to also delay krypton-85 for 3 days.

The hydrogen carrier gas experiences no delay; it passes through the charcoal beds to the plant vent. The recycle line compressors provide the system with the capability to process gases from other areas of the plant by routing the gases to the volume control tank for processing. In addition, the compressors may be used for hydrogen gas recycle where its use is economically justified.

## **SOLID WASTE PROCESSING SYSTEMS**

The solid Waste Processing Systems include the Radwaste Volume Reduction/Solidification System and the Radwaste Incinerator. The systems reduce in volume and solidify low level radioactive plant wastes to prepare them for safe storage and/or disposal.

The Radwaste volume Reduction/solidification System employs a vacuum cooled crystallization process to effect volume reduction, coupled with

high speed, higher shear mixing of the waste with cement to achieve solidification. For combustible plant wastes, the radwaste incinerator utilizes a controlled air incineration process.

Volume reduction of concentrated evaporator bottoms, which may include boric acid wastes, laundry wastes, chemical wastes, and other floor drain wastes, is accomplished in the Radwaste Volume Reduction System (Figure 14-3). The major components of the system are the crystallizer chamber and recirculation system, condenser, and vacuum pump system. The crystallizer chamber consists of a conical tank and an inner circular baffle to separate solid crystals from a clear recycle stream.

Combustible wastes such as clothing, filter cartridges, wood, and the like are volume reduced in the Radwaste Incinerator (Figure 14-4).

Solidification of the volume-reduced wastes and other low-level radioactive wastes, such as spent resins and contaminated tools, is performed in the Cement Solidification System (Figure 14-5). The major components of the Cement solidification System include the high shear radwaste mixer, waste dispensing system, flushwater recycle steam, cement storage and feed system, and the container handling system.

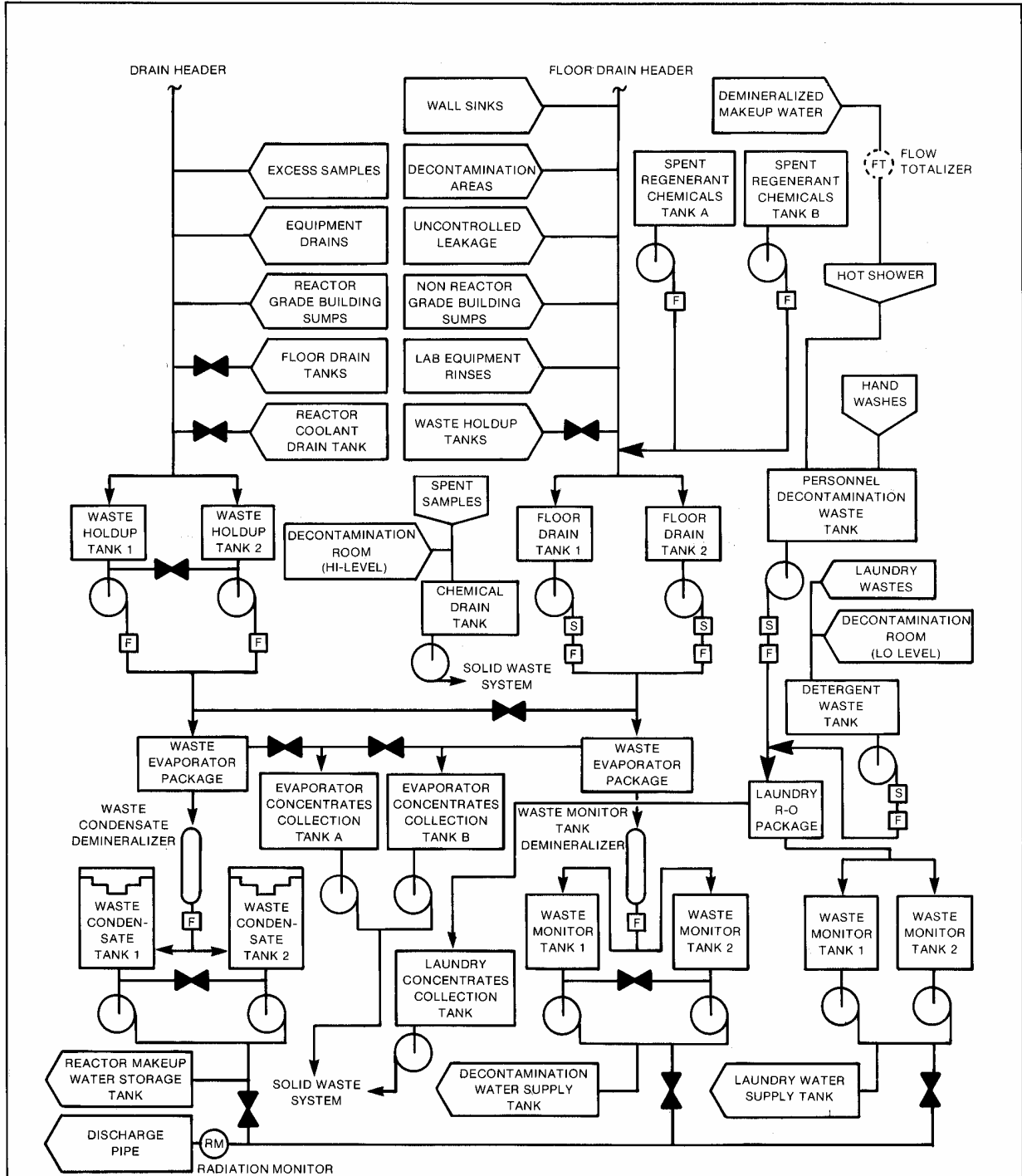
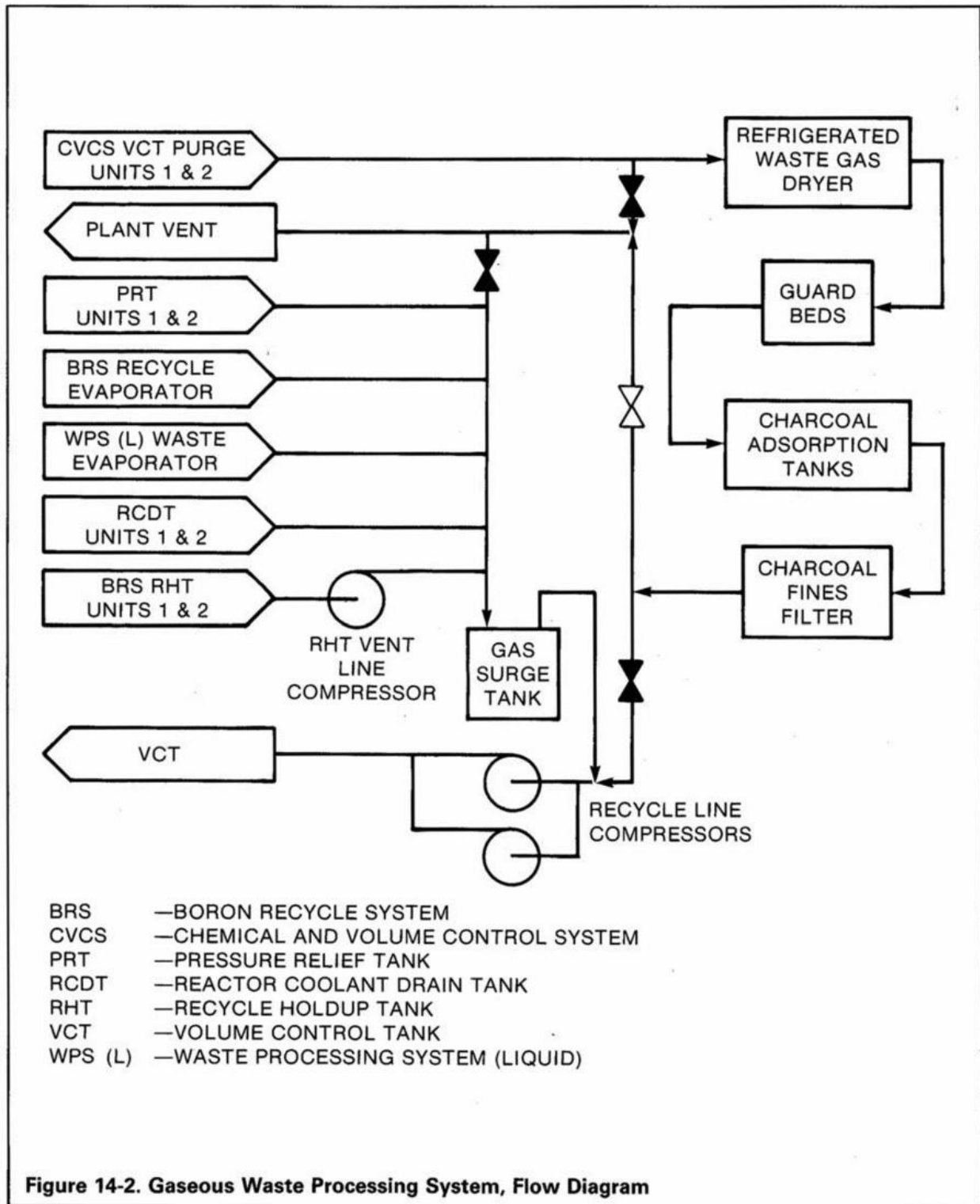

Figure 14-1. Liquid Waste Processing System, Flow Diagram



- BRS —BORON RECYCLE SYSTEM
- CVCS —CHEMICAL AND VOLUME CONTROL SYSTEM
- PRT —PRESSURE RELIEF TANK
- RCdT —REACTOR COOLANT DRAIN TANK
- RHT —RECYCLE HOLDUP TANK
- VCT —VOLUME CONTROL TANK
- WPS (L) —WASTE PROCESSING SYSTEM (LIQUID)

Figure 14-2. Gaseous Waste Processing System, Flow Diagram

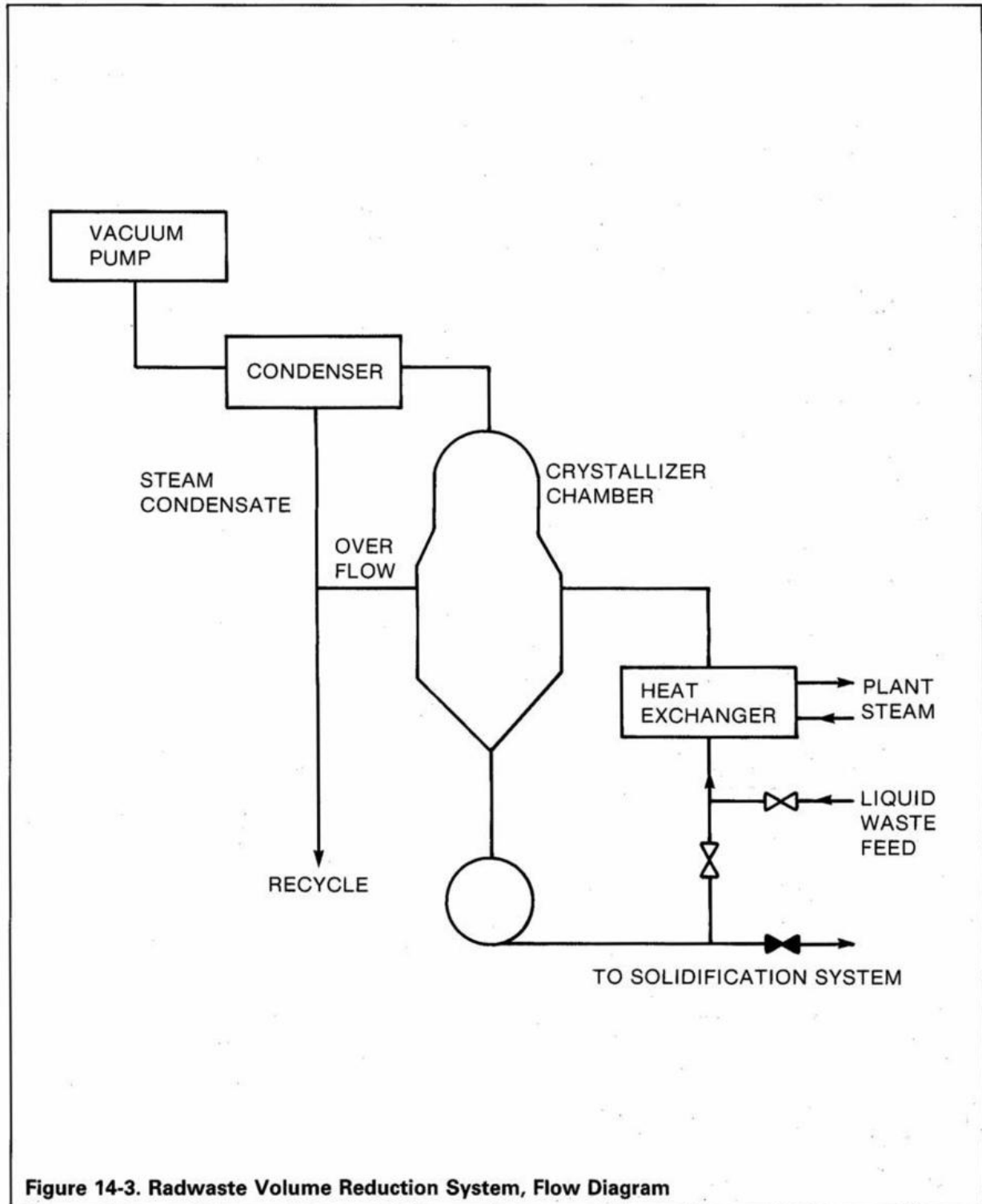

Figure 14-3. Radwaste Volume Reduction System, Flow Diagram

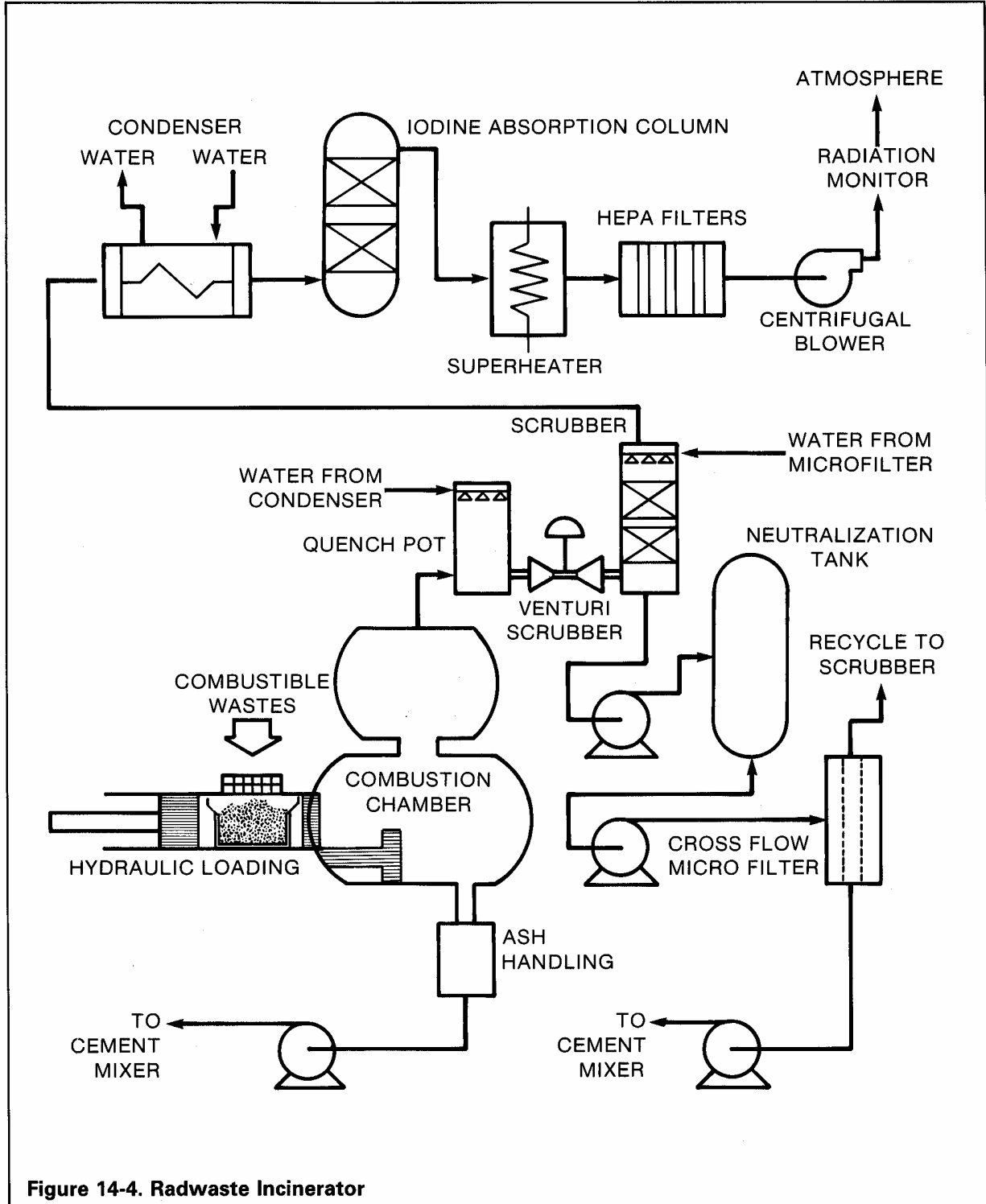

Figure 14-4. Radwaste Incinerator



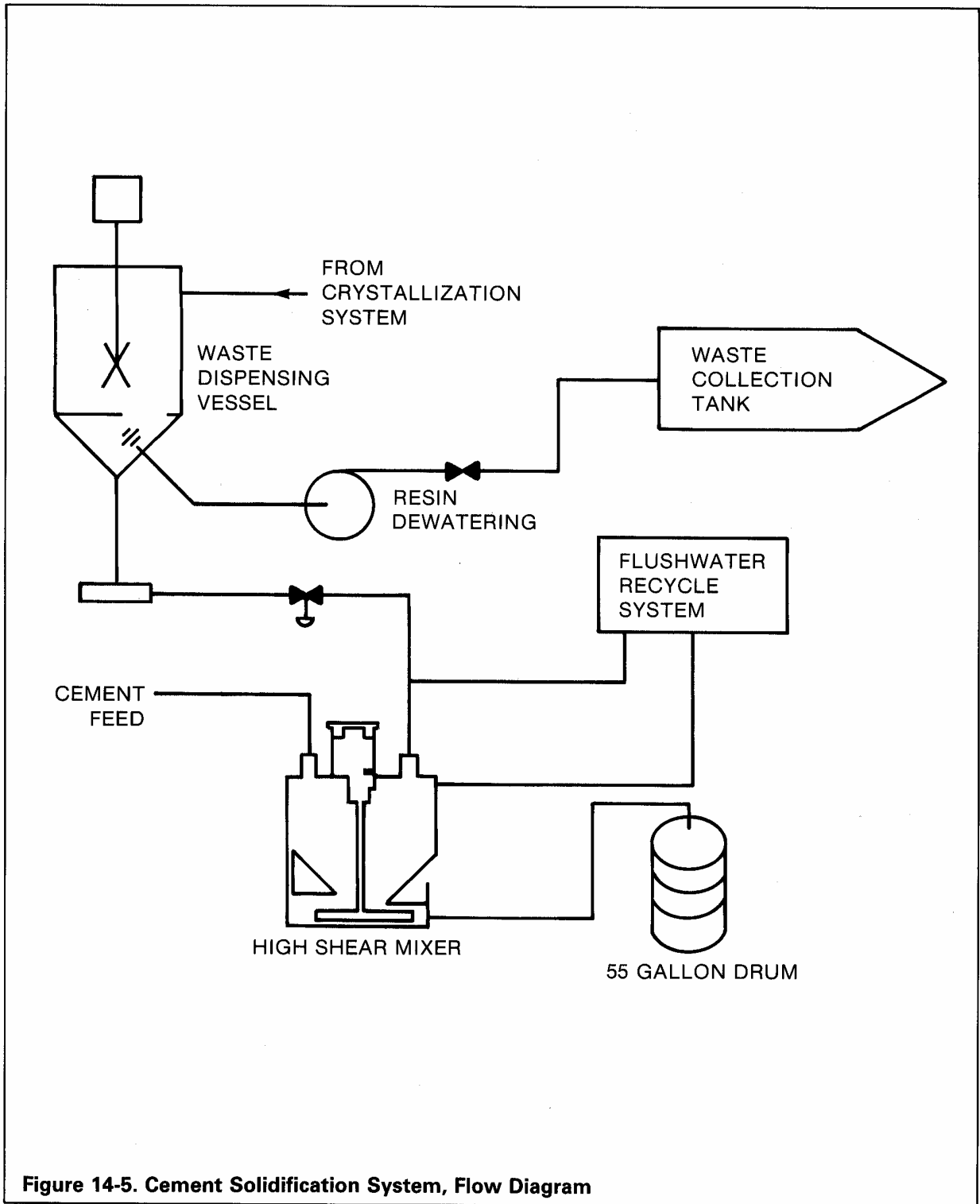

Figure 14-5. Cement Solidification System, Flow Diagram

# **chapter 15**

## **turbine-generator**

### **and related systems**

Steam from the secondary side of the steam generator of the nuclear steam supply system enters the high-pressure element of the turbine-generator, exits to the moisture separator-reheaters and then enters the low-pressure elements. The steam by rotating the blades of the turbine elements (cylinders) rotates the shaft of the generator. The generator produces the electric power of the power plant.

Westinghouse supplies nuclear turbine-generator systems over a load range of 600 megawatts to 1500 megawatts in three- and four-cylinder configurations for any light water reactor. Described in this chapter is the four-cylinder, tandem compound six-flow nuclear turbine-generator (Figure 15-1) for a four-loop Westinghouse PWR nuclear power plant. The turbine-generator can produce up to approximately 1500 MWe with 45-inch last-row blades.

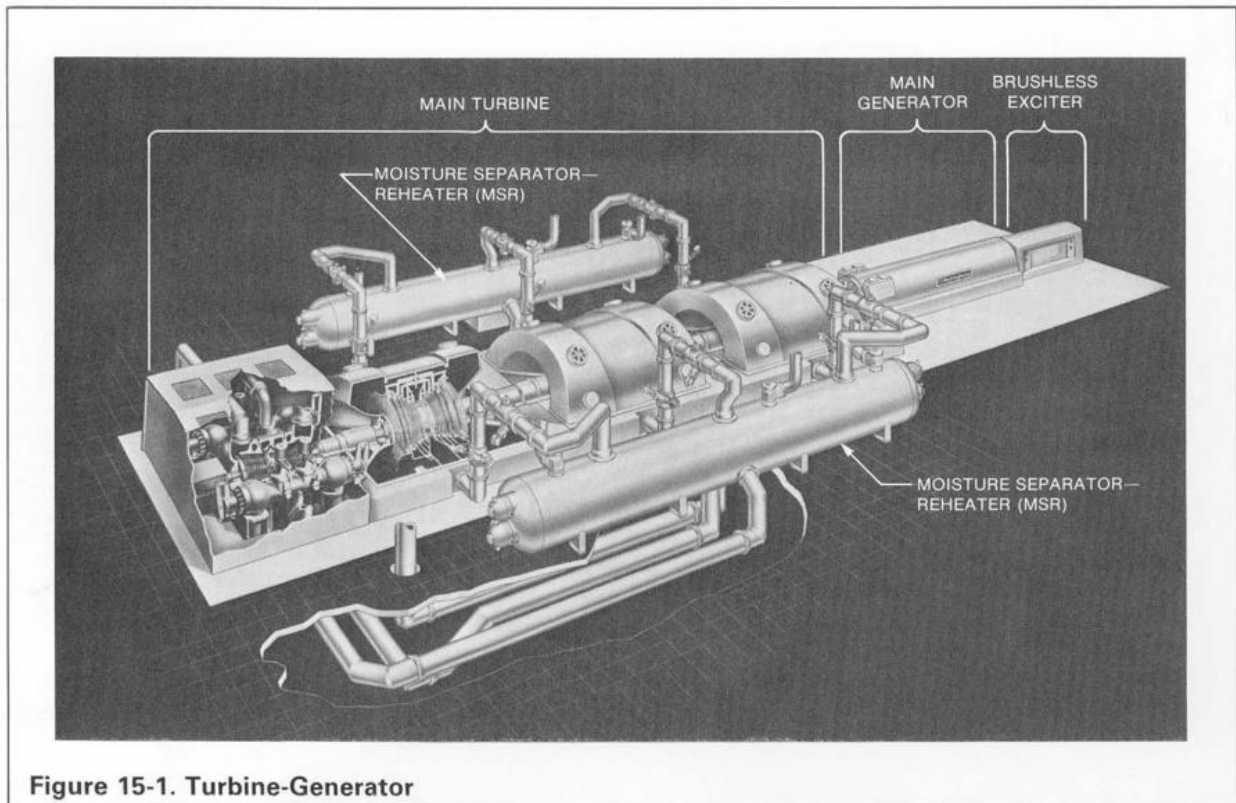

Figure 15-1. Turbine-Generator

# chapter 15.1

## main turbine

### GENERAL DESCRIPTION

The typical main turbine shown in Figure 15.1-1 is a four cylinder 1800 rpm unit with tandem-compound six-flow exhaust and 45inch last row blades. This configuration is used typically for ratings in the 1300 to 1500 MWe range. The main turbine consists of one double-flow high-pressure element (cylinder) in tandem with three double-flow low-pressure elements. Combination moisture separator-reheater assemblies are provided between the high- and low-pressure elements to dry and superheat the steam. Different ratings are obtainable using four-flow exhaust configurations.

The high-pressure turbine is a double-flow element with an impulse control stage followed by reaction blading in each end of the element. The steam enters the high-pressure element through two steam chests, one located on each side of the high-pressure element. Each steam chest contains two throttle-stop valves and two governing valves. The governing valve outlets are connected to the high-pressure element through four inlet pipes, each of which connects to a nozzle chamber enclosed within the high-pressure element. Two of these inlet connections are in the base and two are in the cover. The steam flows axially in both directions from the nozzle chambers, through the control stage and reaction blading to the six exhaust openings (three at each end) two in the cylinder base and one in the cover, then through the crossunder piping to the moisture separator-reheaters.

Crossover pipes return the steam through the reheat stop and interceptor valves to the three low-pressure turbines.

The crossunder and crossover pipes are provided with diaphragm-link, hinge-type expansion joints. These joints absorb the differential pipe movements, utilizing axial pressure load carrying links in conjunction with flat plate diaphragms.

Each low-pressure turbine is a double-flow element employing reaction blading. Steam enters at the center of the blade path, through steam inlets located at the side and below the horizontal joint, flows through the blading to an exhaust opening at each end, then downward to the condenser. Openings are provided in the cylinders through which steam may be extracted for feedwater heating.

### CONTROL VALVES

The main turbine is provided with two steam chest assemblies, one located on each side of the high-pressure turbine. Each assembly consists of two throttle-stop valves and two governing valves. Each valve is controlled by the Digital Electro-Hydraulic governing system through an individually operated valve actuator. These assemblies are isolated from the high-pressure cylinder and are anchored to the foundation.

### CYLINDERS

The double-flow, high-pressure turbine element (cylinder) combines separate nozzle chambers and separate blade rings for high reliability, reaction blading, spring-back seals and effective moisture removal for improved efficiency.

In the double-flow low-pressure turbine element (Figure 15.1-2), where potential temperature differentials are the highest in the unit, temperature gradients are taken across a combination of separate inner cylinder and separate stationary blade rings, thereby increasing reliability by reducing thermal stress on the cylinder. Aero-dynamically designed blade shapes, effective moisture removal, and spring-back seals increase efficiency. Interchangeable rotors and rapid disassembly

features increase serviceability. The Westinghouse low-pressure turbine element may be operated with a slight reduction in load at exhaust pressures as high as eight inches HgA during emergency operations.

### ROTORS

The high-pressure turbine rotor is machined from an alloy steel forging. A separate extension shaft is bolted to the governor end of the rotor to

carry the main oil pump and over-speed trip weight.

The low-pressure turbine rotors (Figure 15.1-3) are of the fully integral design, that is, the discs are integrally forged with the rotor body. The discs are then machined from the forging to their final configuration.

All rotors are finish-machined and after being completely bladed, are given a running test and an accurate dynamic balance test.

Flanged, rigid-type couplings are used to connect the rotors of the high-pressure, No. 1 low-pressure, No. 2 low-pressure, No. 3 low-pressure turbines, and the generator. The rotating element thus formed is supported by ten journal bearings and is located axially by the thrust bearing mounted at the governor end of the No. 2 low-pressure turbine.

The low-pressure rotors are interchangeable because of tolerance control achieved in

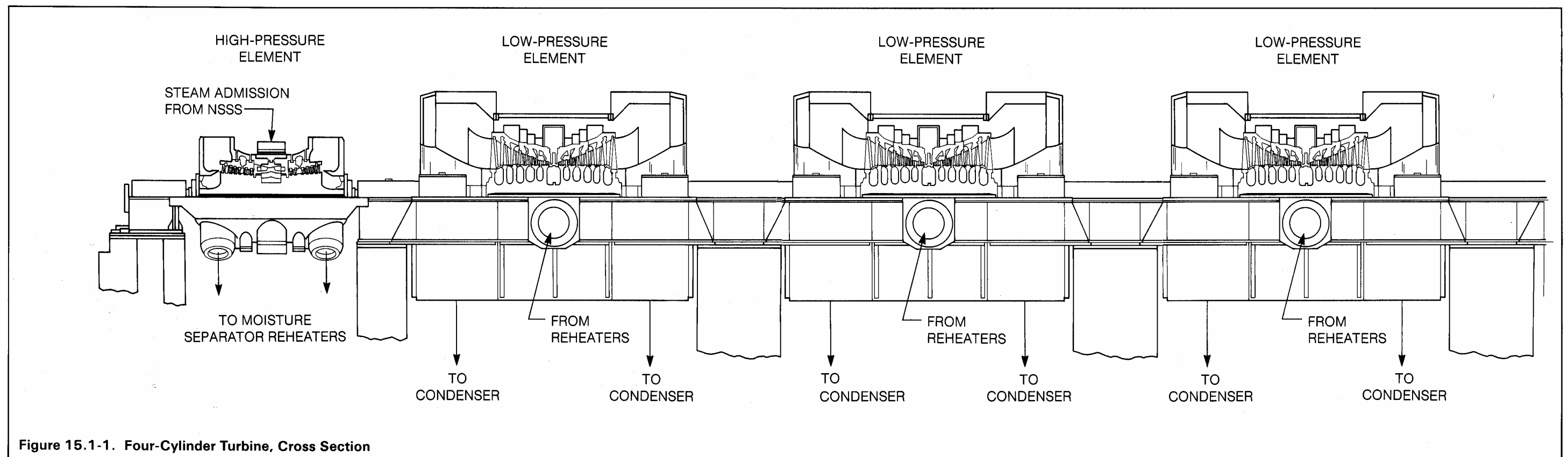

Figure 15.1-1. Four-Cylinder Turbine, Cross Section

manufacturing combined with specially engineered clearances in critical areas. Therefore, spare rotors can be made available to reduce service outage time.

## BLADING

The high-pressure blade path consists of a double-flow control stage followed by double-flow reaction blading. The integral-shroud control stage blades are electro-discharge machined from a solid block of high strength

steel, eliminating fabrication and welding to ensure overall quality and uniformity. The control stage design provides part-load heat rate benefits that sequential valve operation allows. The reaction blading provides overall heat rate advantages, compared to impulse blading, particularly in the area of sustained performance. The lower turning angles in the reaction blade path minimize the tendency to accumulate deposits which can affect basic performance. Also, the reaction blade path design allows more liberal initial seal clearances,

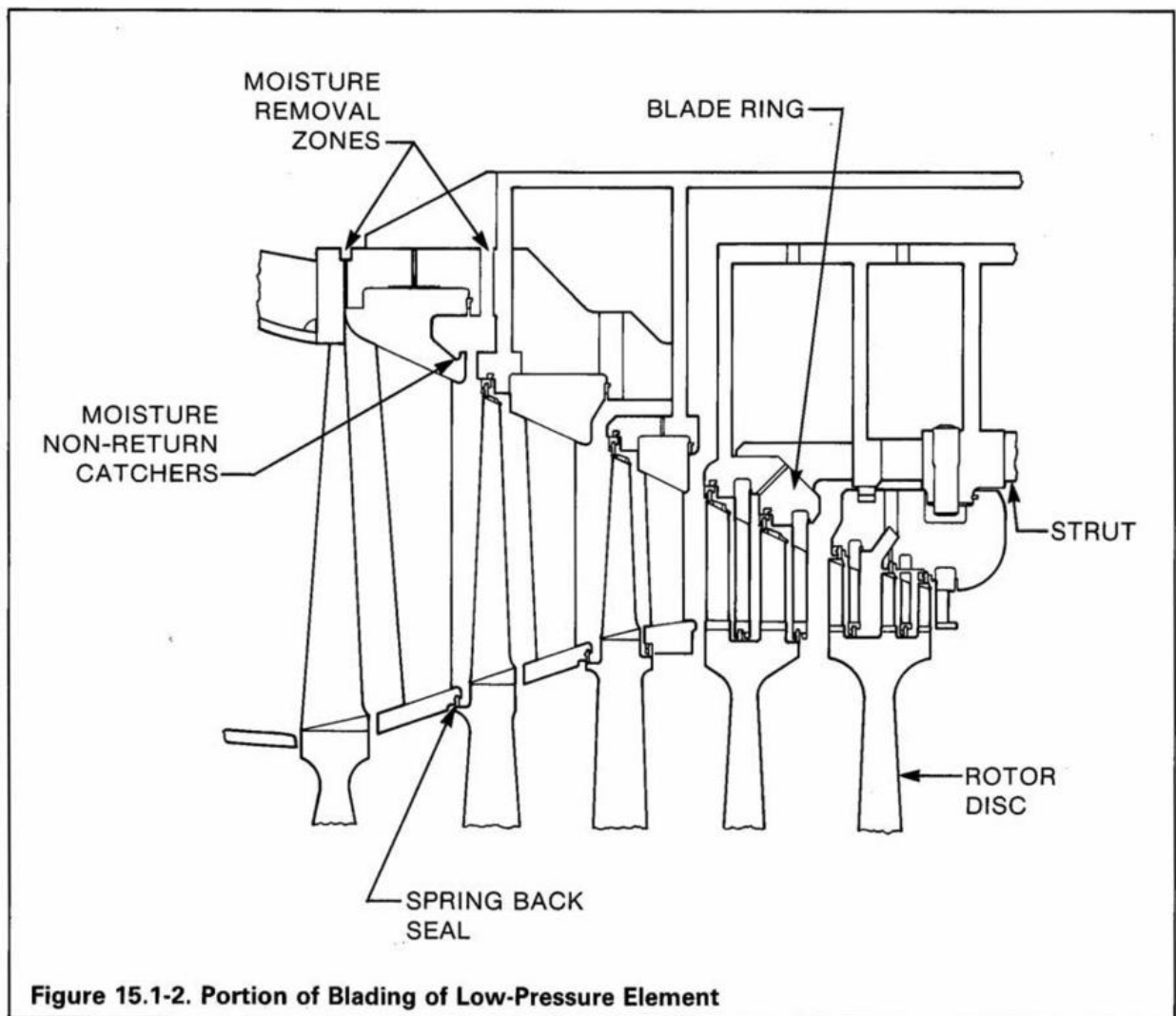

which in conjunction with the use of spring-back seals, enhances the ability of the turbine to maintain initial efficiency over a longer period of operation.

The low-pressure turbine blade path consists of double-flow reaction blading with endurance-strength margins designed to accommodate high exhaust pressure operation. The use of three-dimensional flow field analysis and extensive laboratory, shop and field testing assure uniform steam flow distribution, high efficiency airfoil shapes, and verified endurance-strength margins. Highly effective moisture removal provisions result in improved cycle efficiency and minimization of blade erosion. As in the high-pressure turbine, all seals between rotating and stationary parts are segmental radial spring-back type which result in a high degree of sustained efficiency and reliable operation.

### **ELECTRO-HYDRAULIC CONTROL SYSTEM**

The turbine is equipped with a Digital Electro-Hydraulic Control System (Figure 15.1-4) consisting of a microprocessor-based electronic controller and a high-pressure fire resistant fluid supply.

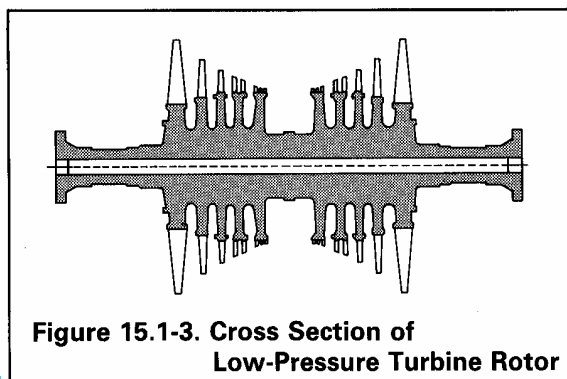

The microprocessor-based electronic controller computes signals comparing turbine speed and first-stage pressure with reference values established by the dispatcher or initiated at the operator's panel. The control signal is transmitted to the electro-hydraulic actuator on the main steam governing valves and reheat steam intercept valves. The high-pressure hydraulic fluid system provides the power for all turbine steam control valve electro-hydraulic actuators, and positions the governing and interceptor valves in response to the electric control signals from the electronic controller.

The Digital Electro-Hydraulic Control System provides:

- (1) Wide range speed control of the turbine from turning gear to rated speed. This control is accomplished by increasing the speed demand (reference) to bring shaft speed to its rated value at a controlled selectable rate. The resolution of this controller is 2 rpm.
- (2) After generator breaker closure, the ability to increase or decrease electrical load at a controlled selectable rate. The resolution of this controller is 0.5 percent load. Function generators in the turbine valve circuits permit either single or sequential valve operation.
- (3) The ability to control phases (1) and (2) above, via optional remote equipment (digital computers, automatic synchronizers, automatic dispatch systems, etc.).
- (4) A manual raise-lower backup system to position the turbine valves in the case of a system contingency.



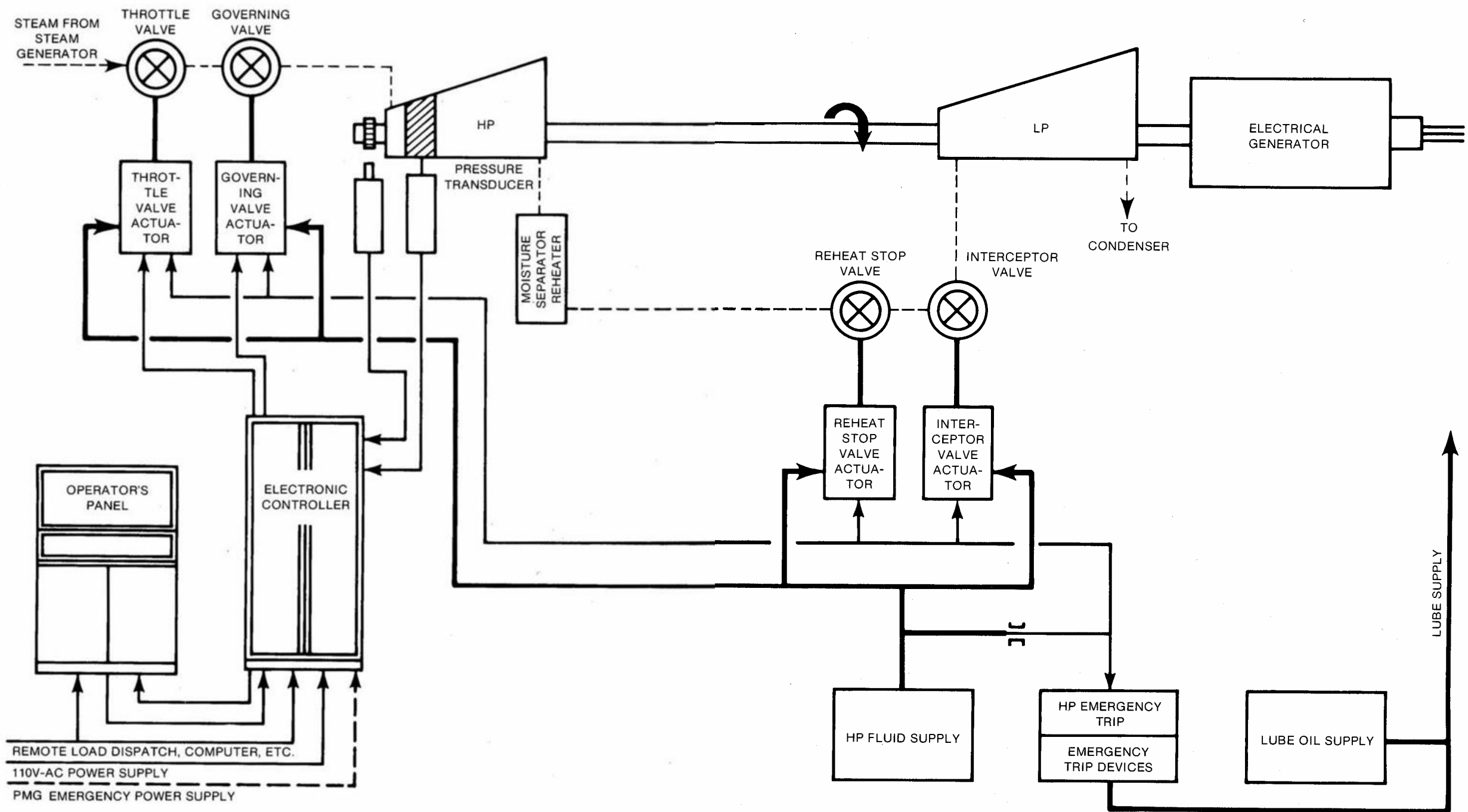

Figure 15.1-4. Electro-Hydraulic Control System for Large Steam Turbine-Generators



- (5) Bumpless transfer circuits to allow mode changes without bumping the turbine.

## Controller

The Digital Electro-Hydraulic Master Control System (DEHM) controls the entire turbine and generator operation, monitors auxiliary equipment and can record data on magnetic storage tape. DEHM has automatic turbine control which includes the turbine master control panel module. It displays important data on a color-graphic CRT and has the capability for a direct or modem digital link for use with other computers. It consists of two separate base auto controllers which duplicately receive inputs from transducers, panel pushbuttons, and process relay contacts. Identical protective algorithms are independently executed and protective action is taken when either controller detects the need, thereby providing redundant protection. Control is performed only by the auto controller in command and results in a set of control output data. The standby auto controller carries out control output reasonability and system integrity checks and is ready for control transfer at all times. There are dual communication buses which are used to transmit data among the auto controllers, the valve servo drivers, and the overspeed protection controller (OPC) channels. (Figure 15.1-5).

The two speed channels and OPC redundantly provide OPC alarm (103%), OPC trip (110%), and fast valving functions. They interact directly with the valve servo drivers and communicate their status to the auto controllers.

The DEHM supervises all turbine-generator operation from checking the bearing oil pump before startup, through startup and synchroni-

zation to load changes after the turbine is on line. It controls valve changes and monitors output power, the power factor, and speed to ensure that the limits of the generator are not exceeded.

The DEHM monitors rotor stress during operation. It maintains a dynamic temperature model of the high-pressure rotor first stage section, calculates present and anticipated rotor bore stresses, compares rotor stresses against their limits, and calculates rotor stress margins to determine permissible load changes. The DEHM informs the operator of problems in the rotor and calculates the expected rotor cycle life.

## Operator's Panel

A typical operator's panel for the base system controller is shown in Figure 15.1-6. The panel consists of the following modules:

- Status
- Auto Control
- Manual Control
- Maintenance and Test
- CRT

The master controller (Figure 15.1-7) includes the automatic turbine control (ATC), a color-graphic CRT and optional interfaces such as for a plant master controller. The color-graphic CRT uses graphic color displays to present information to the operator in a readable and understandable manner.

Normally, the operator controls the unit in the automatic turbine control mode while supervising the operation via the color-graphics CRT.

Unit operation may also be controlled in the auto control mode. In this mode the operator uses the CRT and auto control module to select speed or load demand, rate of change, limits, control modes, etc. In addition, calculated and measured data can be displayed on operator command.

The manual mode of control provides simple direct control of the valve positioning electronic signals.

## Operation

Turbine control is achieved by varying the turbine valves' openings. Hydraulic cylinders move the valves to the required opening with electrically operated servo valves controlling the valves' positions. The servo valves' electrical positioning signals originate in the controller circuitry. The operator may position the valves, when necessary, through the manual valve controllers.

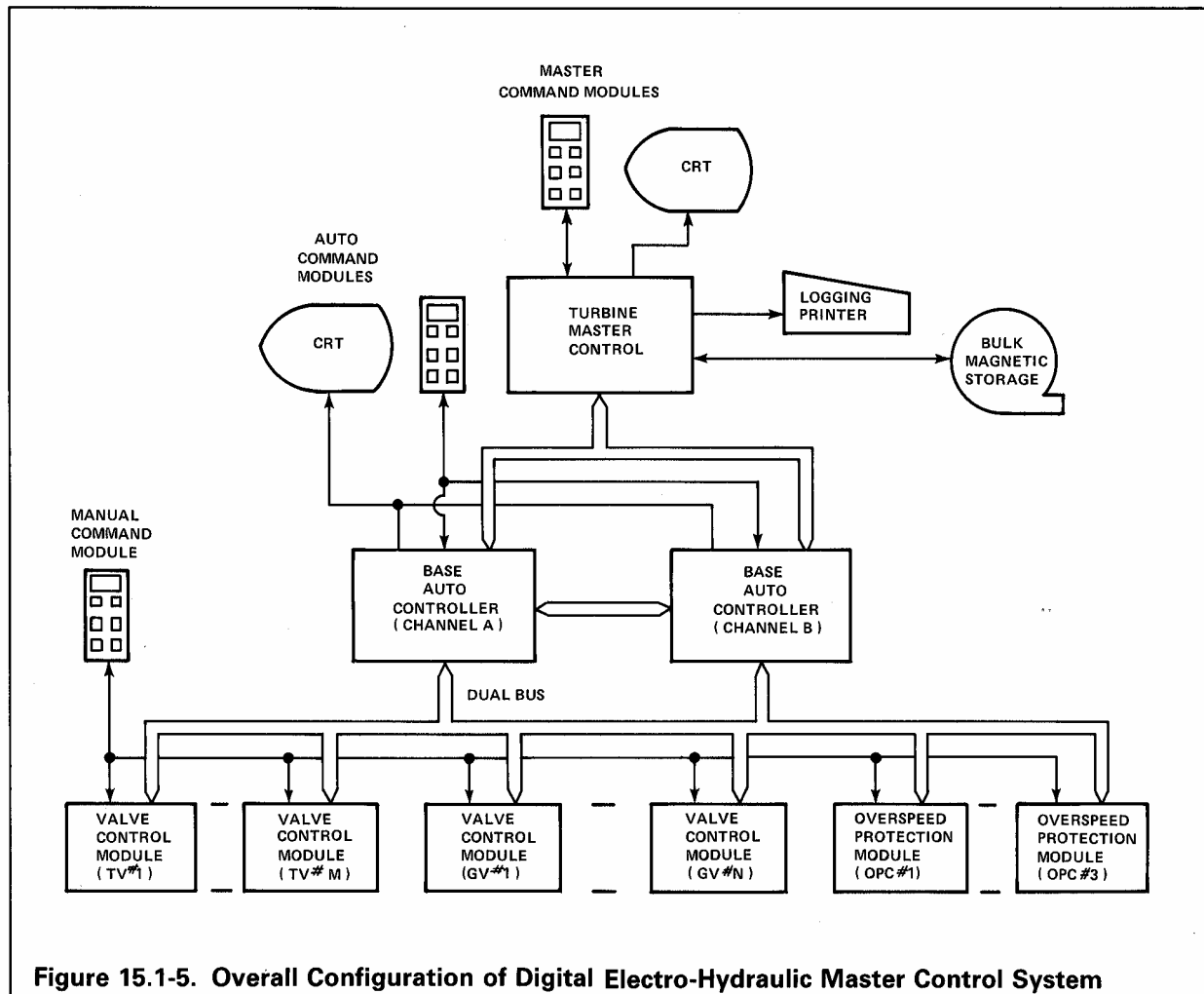

Figure 15.1-5. Overall Configuration of Digital Electro-Hydraulic Master Control System

## PROTECTIVE DEVICES

A mechanical-hydraulic emergency trip system completely independent of the Electro-Hydraulic Control System is provided. This system uses oil from the turbine-generator lubricating system. Release of this oil, called auto stop oil, by any one of the turbine trip devices listed in this section causes all steam control valves to close. Besides the mechanical-hydraulic overspeed trip mechanism in this system, a redundant overspeed trip system is available to ensure that the

turbine speed does not exceed 120 percent of design speed.

The following turbine protective devices are independent of the Electro-Hydraulic Control System, and when initiated, cause tripping of all turbine valves through the emergency trip valve:

- (1) Mechanical hydraulic and electrical overspeed trip
- (2) Low bearing oil pressure trip
- (3) Low vacuum trip

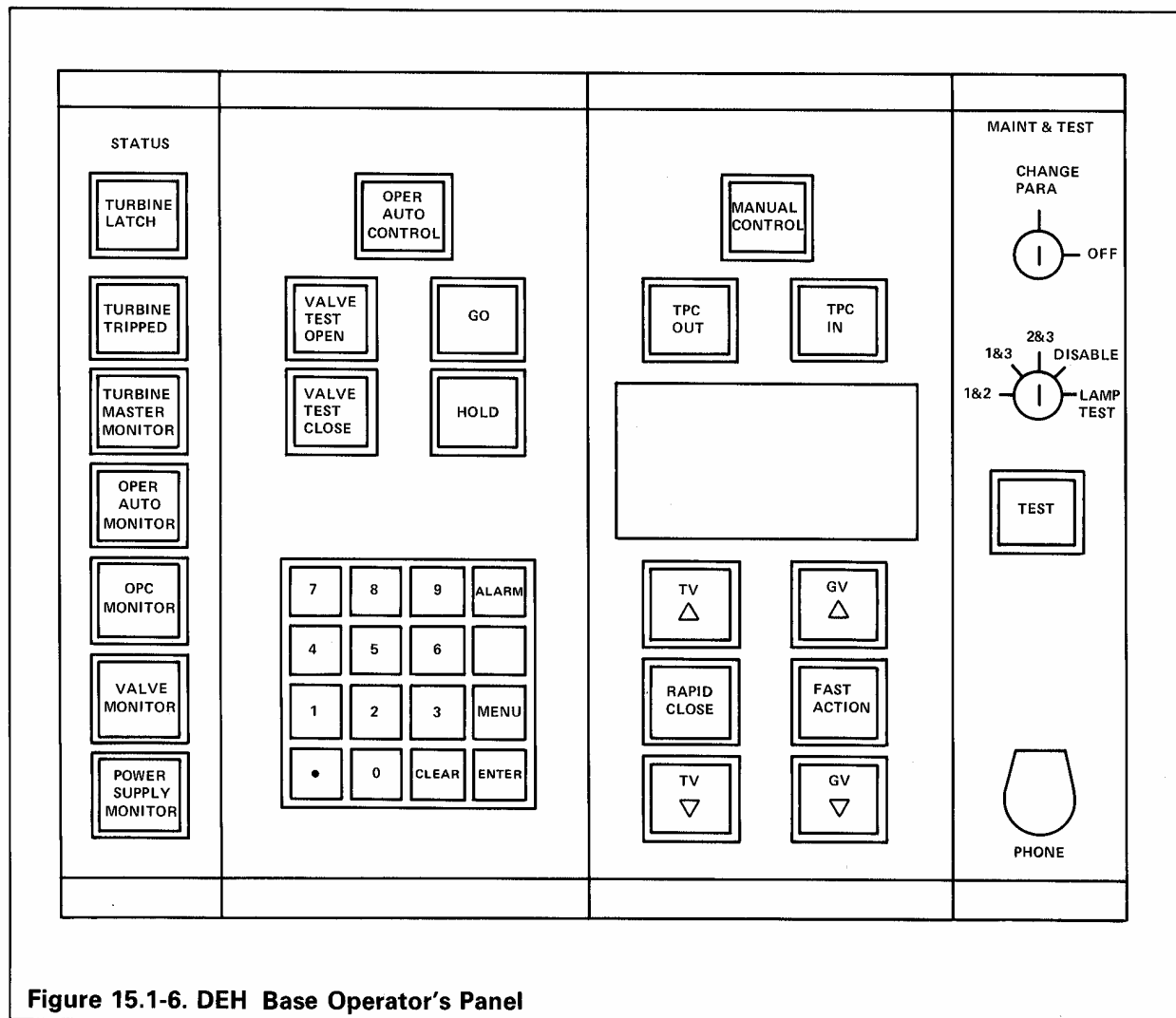

Figure 15.1-6. DEH Base Operator's Panel

- (4) Thrust bearing trip
- (5) Electrical solenoid trip
- (6) Manual trip at turbine governor pedestal.

The mechanical hydraulic overspeed trip mechanism (Item 1) causes the turbine valve hydraulic fluid pressure to dump to drain, thereby closing the main steam stop and governing valves and the reheat steam stop and intercept valves at a pre-selected percent above rated speed. The other protective devices are all included in a separate assembly, but connect hydraulically to the overspeed trip valve through the trip relay. Actuation of any one of these devices therefore causes the turbine valve hydraulic fluid to be dumped to drain.

Additional protective features for the NSSS and turbine are also provided by normal turbine controls, turbine interlocks, and the piping system safety valves as follows:

- (1) Automatic load runback initiated by a dropped rod signal, high kw/ft signal or low departure from nucleate boiling ratio signal.

- (2) Turbine trip following a reactor trip.
- (3) Stop valve and check valve in each steam generator outlet main steam line.
- (4) Safety valves in each steam generator outlet main steam line.
- (5) Safety valves in the moisture-separator reheat outlet piping.
- (6) Extraction line nonreturn valves.
- (7) Atmospheric steam dump valves.
- (8) Condenser steam dump valves.

Automatic turbine load runback via load limit for a dropped rod control cluster assembly is initiated by either a rapid decrease in nuclear flux or by the rod bottom circuitry. Automatic turbine load runback via load reference is initiated by the dropped rod signal, high kw/ft, or low departure from nucleate boiling ratio signal.

The extraction steam nonreturn valves are actuated from the turbine hydraulic fluid system via an air pilot valve which dumps the air pressure to each extraction steam air-operated nonreturn valve.

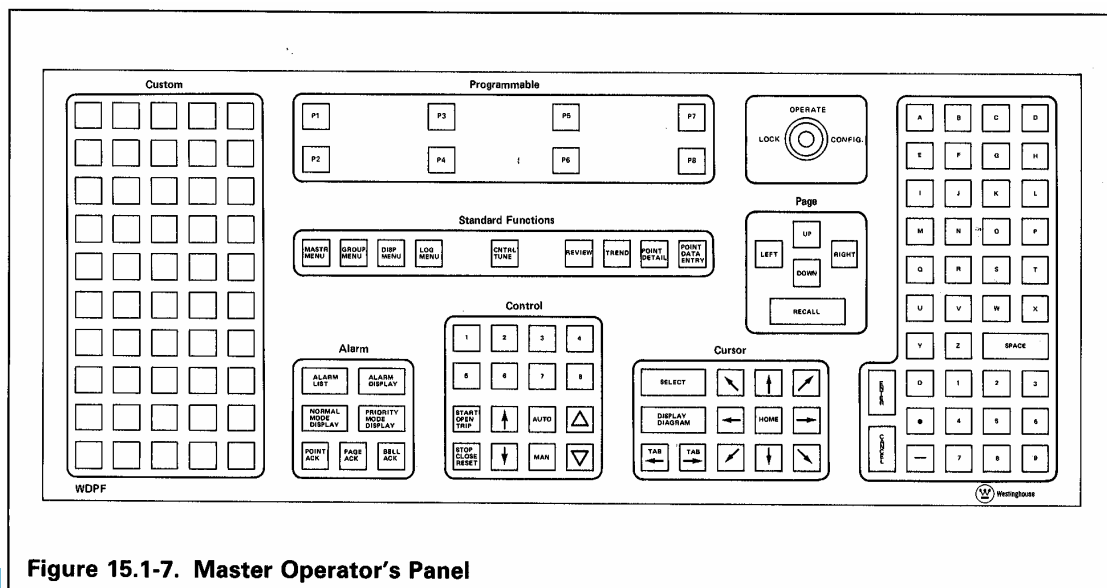

Figure 15.1-7. Master Operator's Panel

# chapter 15.2

## main generator

A typical main generator for large nuclear station application at 60 Hertz is shown in Figure 15.2-1.

The stator winding is water cooled using demineralized water supplied at a lower pressure than the hydrogen gas pressure. Stator core laminations and the entire stator core and winding assembly are flexible spring mounted to minimize the double frequency vibration generated in the stator core. The rotor is a cylindrical forging made of high strength, high permeability alloy steel produced using the vacuum degassing process.

Principal parameters of the main generator are as follows:

**Type:** Hydrogen inner-cooled synchronous generator with a water-cooled stator

**Rating:** 1370 mva

**Power factor:** 0.9, short circuit ratio: 0.58

**Hydrogen pressure:** 60 or 75 psig

**Output voltage:** 24,000 to 26,000 volts, three-phase, 60 Hz

**Speed:** 1800 rpm

**Excitation:** Shaft-driven, air-cooled brushless exciter of the rotating rectifier type

### VENTILATION

The hydrogen gas is circulated by a blower mounted on the generator rotor. After the

hydrogen passes through the hydrogen coolers where heat is transferred to service water, the cold hydrogen passes through internal ducts in the frame and enters holes at the exciter end of the core where it then passes axially through the core and returns to the blower. A portion of the cold gas leaving the cooler is directed by means of baffles and ventilating passages through the rotor. This gas enters the rotor at each end, flowing through the ventilating passages provided in the rotor copper for direct cooling. It discharges from holes at the center of the rotor and returns through the air gap to the blower for recirculation.

Four hydrogen coolers are mounted horizontally at the top of the generator. The cooler consists of two separate sections to permit temporary operation at reduced load with one section out of service.

### STATOR COILS AND WINDING

The stator coils are single turn coils consisting of both hollow and solid strands as shown in Figure 15.2-2. The demineralized water used for cooling passes through each bar in a single pass and is returned to the stator water system for cooling, treating, and recirculation. Thermalastic epoxy insulation is used to provide the ground wall insulation to give high dielectric and mechanical strength. The vacuum impregnation process used results in superior dielectric and mechanical properties. The thermalastic character of the resin provides a solid yet elastic physical bond between the mica flakes to provide a resilient insulation system capable of withstanding the expansion and contraction experience with load changes. A nonmetallic ripple spring assembled under the slot wedge exerts radial pressure on the coil to prevent coil

bounce due to coil double frequency vibration thus maintaining tight wedges and coils.

The stator winding including the parallel ring connections, main terminal bushings, current transformer, and neutral bus are also water cooled. Vibration is controlled in the end winding by glass epoxy blocking between all coils and support rings between top and bottom coils, all combined with glass bonding and impregnated conformable materials. This bracing structure provides the necessary rigidity to withstand short circuit faults as well as provide the flexibility needed for thermal expansion and contraction.

## GENERATOR ROTOR

The rotor winding is made up of hollow conductors, each consisting of two copper

channel sections through which the hydrogen gas flows. The winding is held firmly against rotational forces by nonmagnetic retaining rings and high strength rotor slot wedges.

The rotor winding end retaining rings are nonmagnetic steel forgings produced by an expanding process and are shrunk onto machined sections of the rotor body ends. Refer to Figure 15.2-3.

The end winding curved sections – potentially high stress areas – are arranged with brazed connections located well away from the curves. Axial expansion is controlled by allowing for expansion and by including teflon slip layers in the rotor slots and under the retaining ring to minimize the friction that opposes axial motion. The completed rotor is statically and dynamically

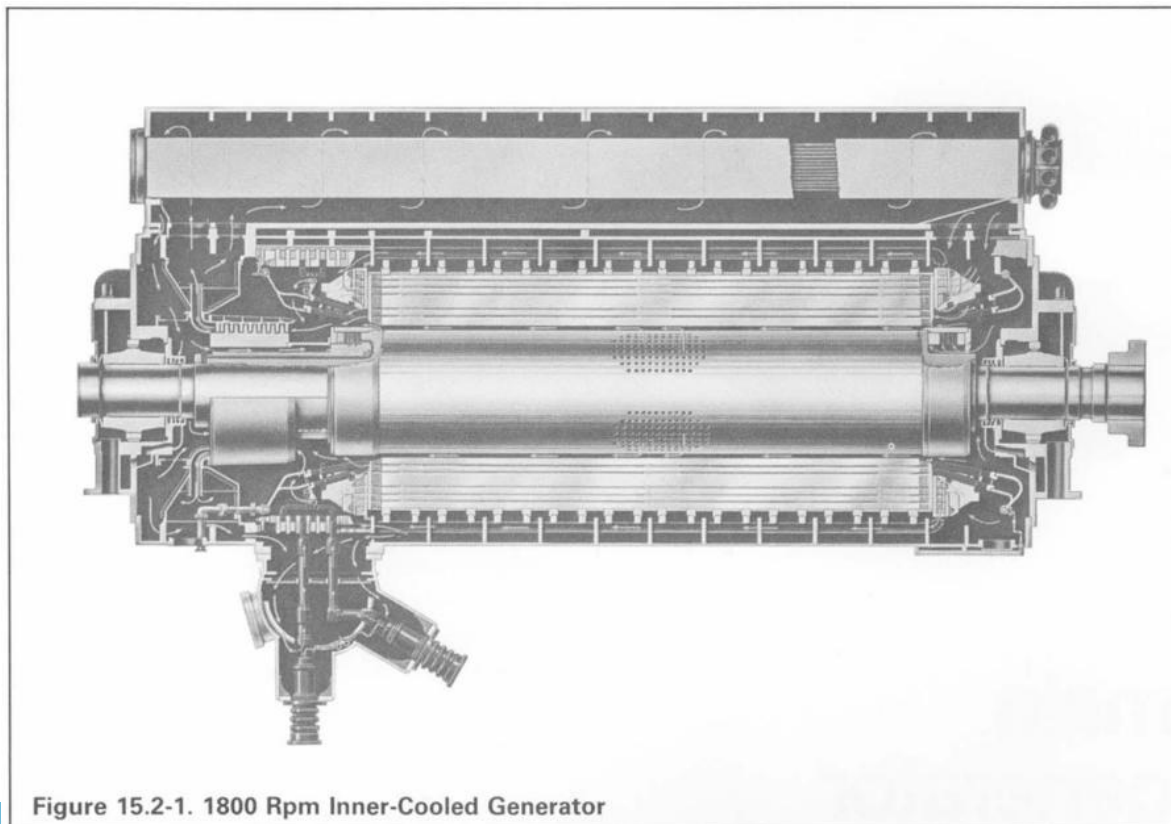

Figure 15.2-1. 1800 Rpm Inner-Cooled Generator

balanced to controlled tolerances. It is carefully baked and conditioned at running speed to promote lasting stability of the rotor winding components.

### STATOR COIL COOLING WATER SYSTEM

Demineralized cooling water is provided for the stator by a closed recirculating water system (Figure 15.2-4). The treated water is supplied to the generator through stainless steel piping. All materials in contact with the treated water are corrosion resisting materials. In addition, the water tank is pressurized with hydrogen to further minimize oxidation. Redundancy is provided in the water pumps, water coolers, and

the alarm system so that safe, reliable operation is assured under all conditions.

### EXCITATION SYSTEM

The Westinghouse Mark III Brushless Exciter (Figures 15.2-5 and 15.2-6) is designed so that all high-power components are mounted on the shaft. This eliminates the need for troublesome carbon brushes and complicated brush rigging assemblies. It also eliminates any high-power buswork external to the exciter housing. The result is greatly decreased installation, maintenance, and operating expense. The performance of the brushless excitation system is not affected by reduced system voltage during system disturbances as are other excitation systems.

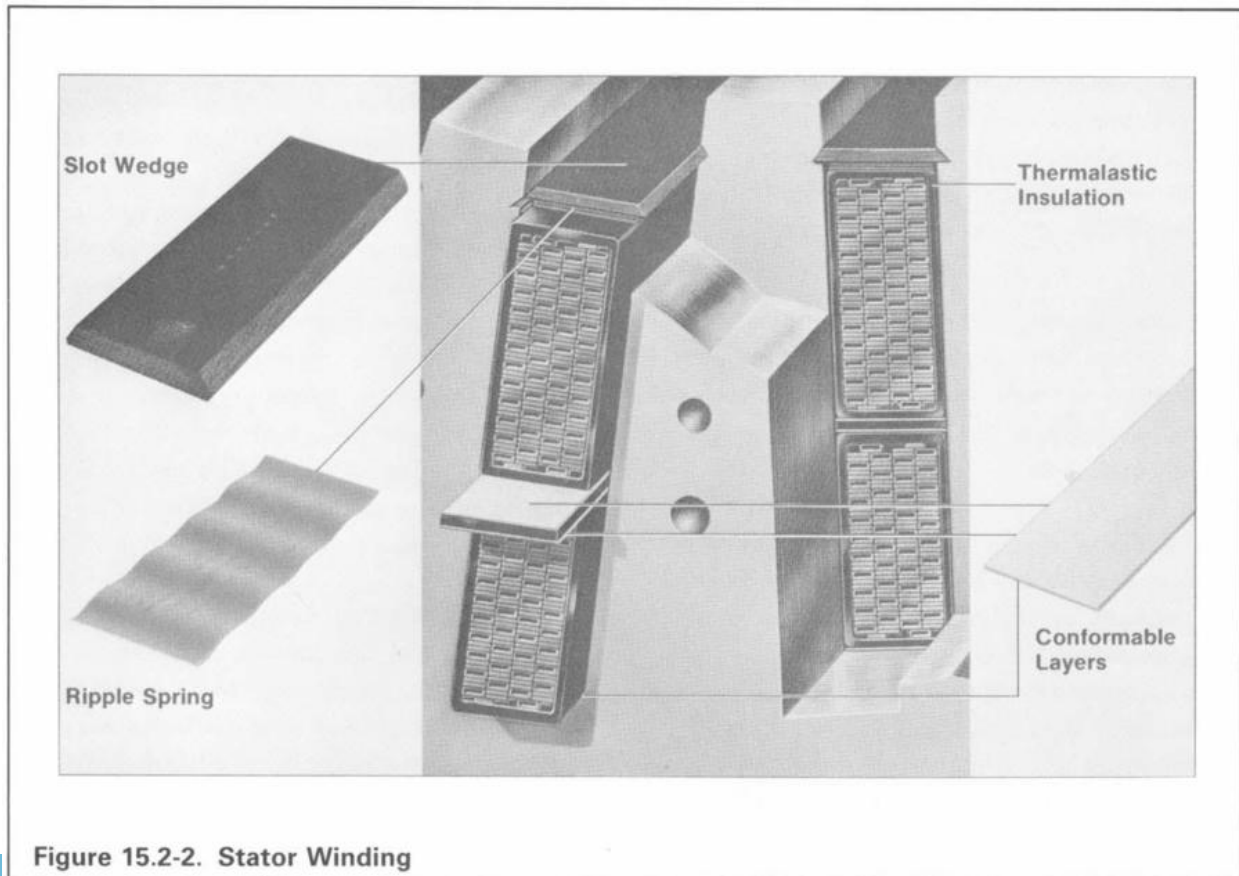

Figure 15.2-2. Stator Winding



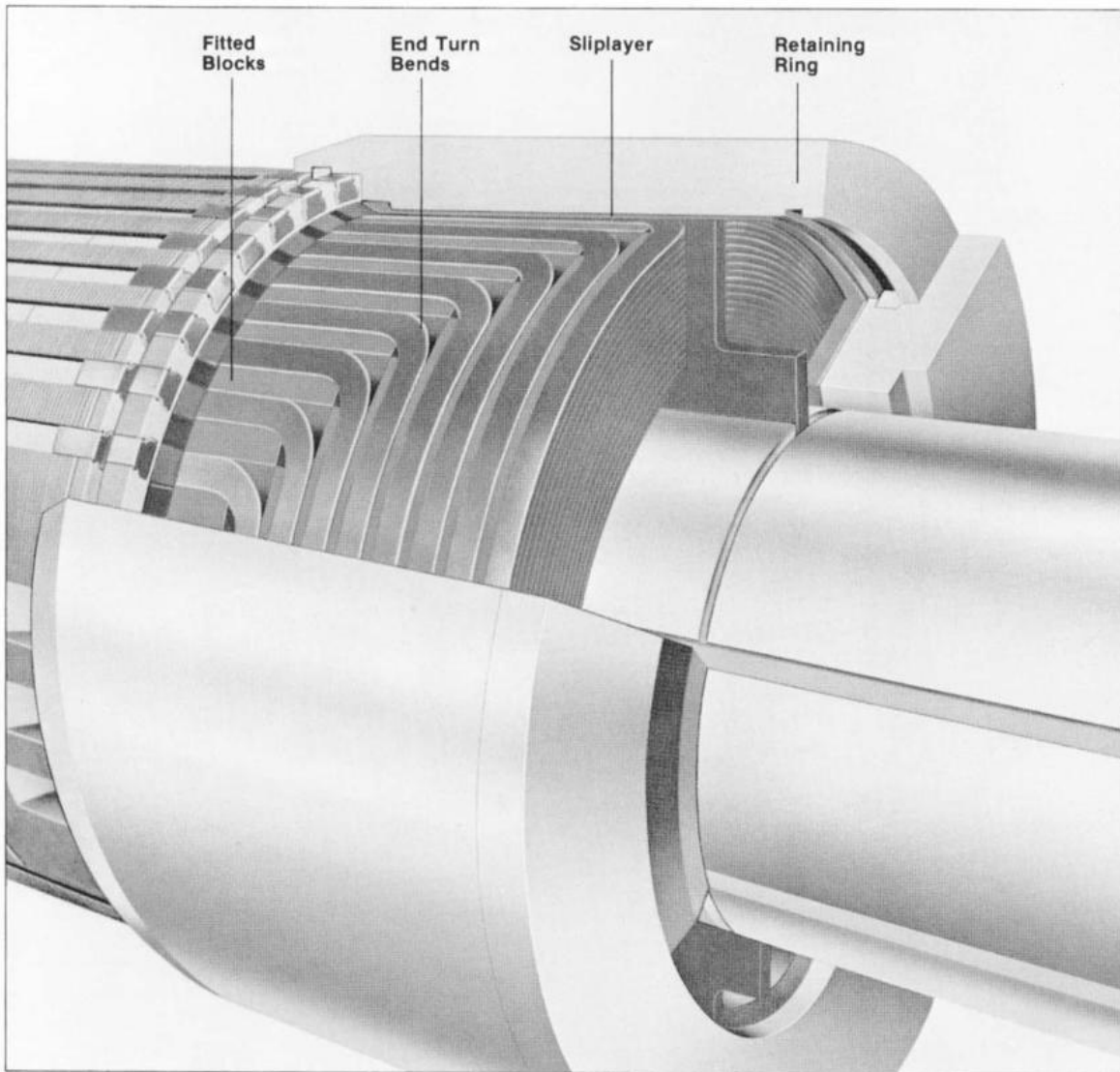
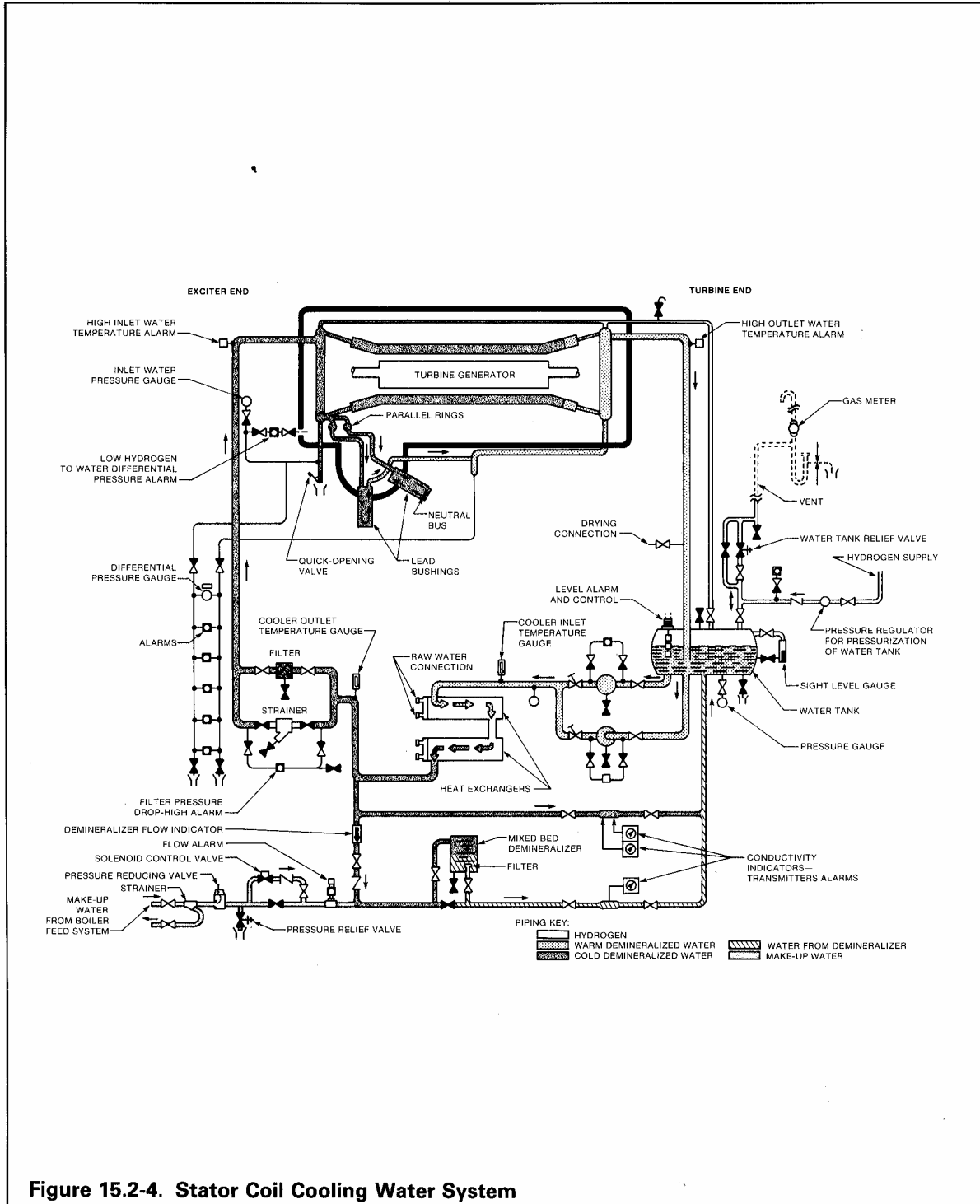

Figure 15.2-3. Rotor End Winding





The Type WTA-300 voltage regulating system is of the latest design incorporating all solid state circuitry in the regulating system logic functions. It has been designed to retain many of the features associated with the previous Type WTA and the Type WMA Mag-A-Stat voltage regulators, the latter of which was first applied in brushless excitation systems in 1958.

The Type WTA-300 reflects advancement in the art of solid state circuitry.

The brushless exciter is completely housed in a self-ventilated enclosure and consists of three basic parts: a permanent magnet pilot exciter, a main ac exciter, and a rectifier wheel.

The alternating current output from the rotating exciter armature is fed along the shaft to silicon diodes mounted on the rotating diode wheels. The exciter output is thus rectified and the resultant direct current is carried by rotating components on the shaft to the main generator field winding.

The high-frequency permanent magnet generator provides power to the automatic voltage regulator which regulates and controls the output of the exciter to control the generator voltage.

The system is protected against diode failure by series connected fuses having indicating devices which may be inspected during operation. The diodes and fuses are arranged in modular construction for ease of maintenance.

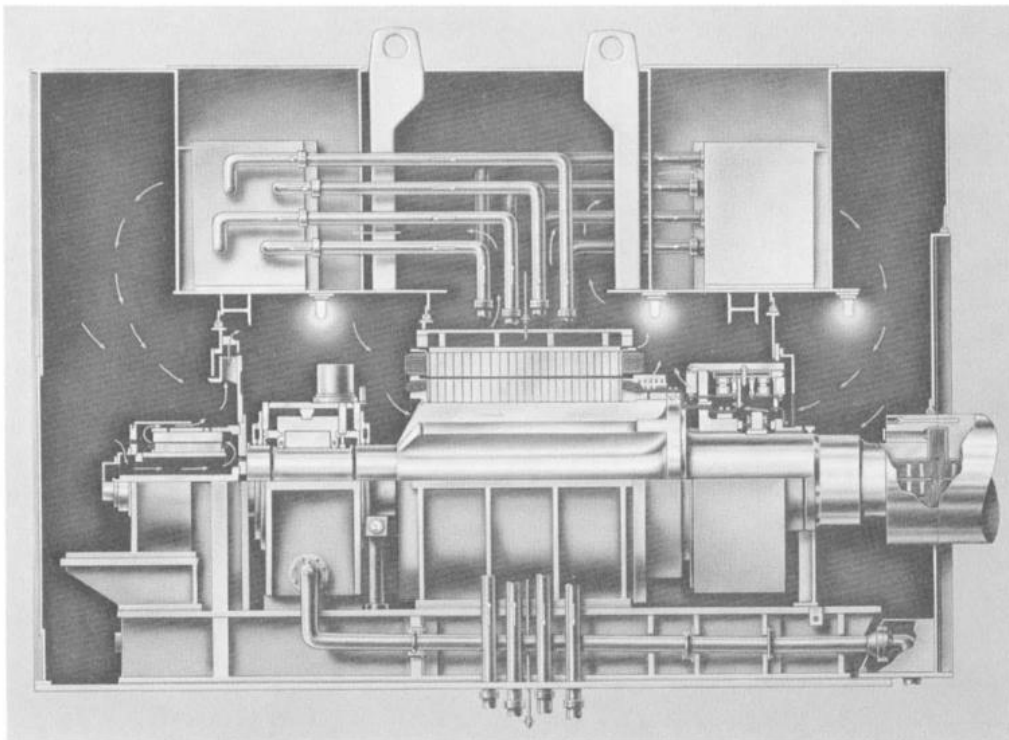

Figure 15.2-5. Cutaway of Brushless Exciter

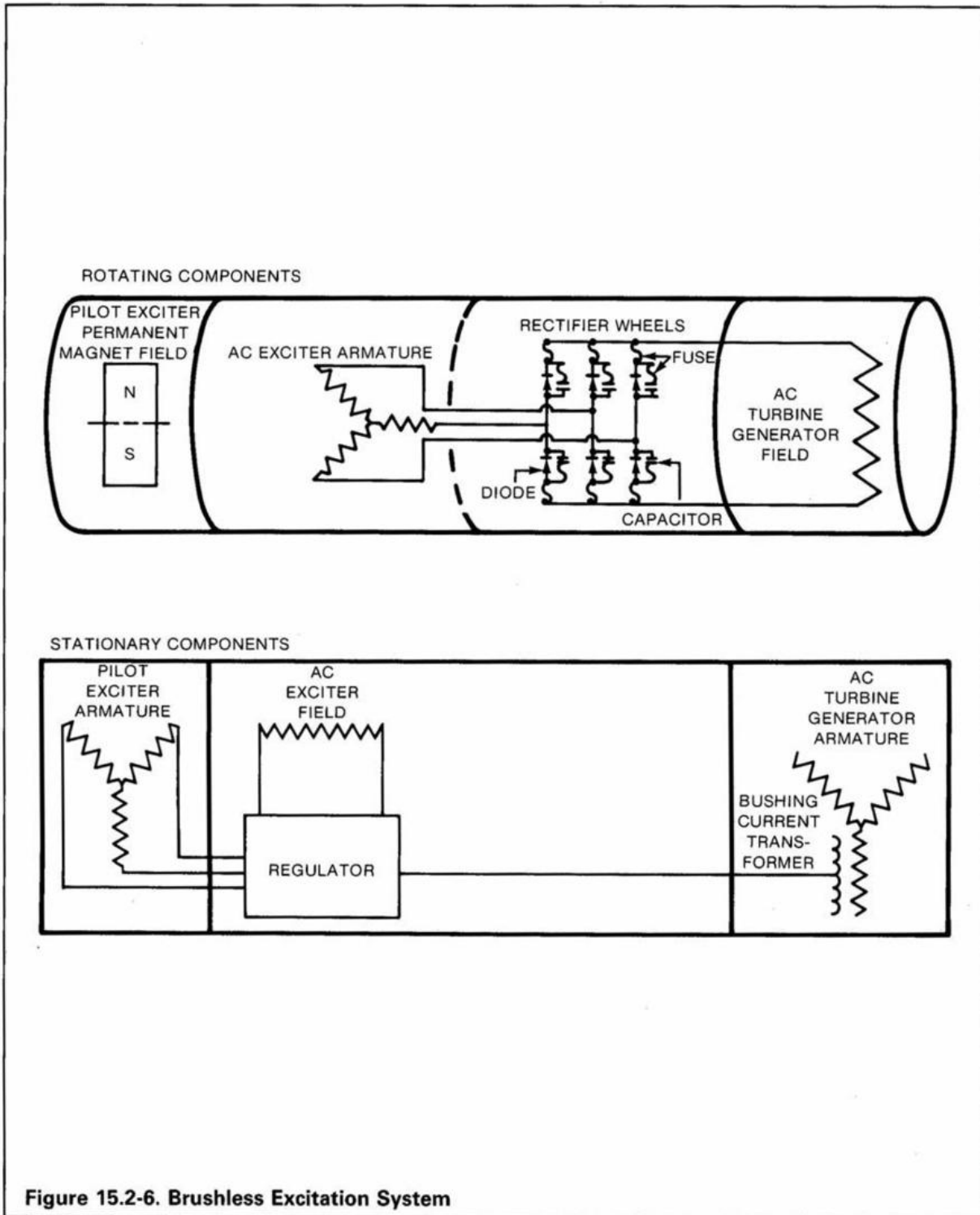

Figure 15.2-6. Brushless Excitation System

# chapter 15.3

## main steam and repeaters

### MAIN STEAM

During operation, the four steam generators deliver saturated steam through four steam lines to the main turbine. These lines are cross-tied near the turbine to ensure that the pressure difference between any of the steam generators does not exceed 10 psi (0.69 bar) thus maintaining system balance and ensuring uniform heat removal from the Reactor Coolant System. A flow diagram of a typical steam, condensate, and feedwater system is shown in Figure 15.3-1.

Each steam line is routed from its steam generator to a containment penetration by a route outside the secondary shield wall to prevent failures in one loop from affecting a second. A flow limiter which is integrated into the design of the steam generator will limit the cooldown rate of the Reactor Coolant System if a steam line break occurs upstream of the main steam stop valves.

The main steam lines are provided with a stop valve and a check valve in each line just outside the containment. The main steam piping up to valves and the stop valves are ANS Safety Class 2. The structure enclosing the valves is designed as seismic Class 1. The main steam stop valves automatically close on low steam line pressure or on a high-high containment pressure signal, and can be actuated manually from the main control room or local panels. The swing check valves protect against backflow of

steam in the event of a steam line break inside the containment. The Safety Class portions of the main steam and feedwater lines are protected against potential missile effects and are provided with restraints to preclude additional line failures due to pipe whip in the event of a main steam or feedwater line break. ASME Code safety valves and power operated relief and atmospheric dump valves are located on each steam line upstream of the stop valves.

A small portion of the steam in the high-pressure turbine is extracted to the highest pressure feedwater heaters; the remainder is exhausted to moisture separator-re heaters with a small extraction to the sixth stage feedwater heaters. In the moisture separator-reheaters, moisture is mechanically separated from the turbine steam and the steam is then super heated before entering the three low-pressure turbines. Several stages of extraction are used for the feedwater heaters. The greater portion of the steam is fully expanded through the turbine before being exhausted to the condenser.

### REHEAT STEAM

Typical combined moisture separator-reheaters (Figure 15.3-2) between the high-pressure and low-pressure turbine elements remove the moisture in the wet steam exhausting from the high-pressure element exhaust and reheat the steam to over 100°F (55°C) superheat. The wet steam enters the moisture removal section and rises through chevron-type moisture-separators where the water is removed and drained to the feedwater system. The dried steam then passes through the reheater section where it is reheated by the highest pressure extraction steam and by main steam withdrawn before the throttle valves. The heating steam is condensed in the tubes and is drained to the feedwater system. The

reheated steam goes to the low-pressure turbines and to the two main feedwater pump turbines.

## **CONDENSING EQUIPMENT**

The main condenser condenses the exhaust from the main turbines and the two feedwater pump turbines. There is also sufficient surface to condense steam from the steam dump system with an acceptable increase in turbine back pressure. The condenser is usually a single-pass deaerating type with straight-through tubes. Under normal operation the air is removed by steam jet air ejectors or vacuum pumps.

## **TURBINE STEAM DUMP SYSTEM**

The steam dump system (Figure 15.3-3) is provided to accommodate the inertial heat from the primary cycle. Inertial heat, in the form of steam generated in excess of turbine demand, is present at times of sudden load reduction since

the nuclear power cannot be instantly reduced. This heat is rejected to the condenser through the steam dump valves and to the atmosphere for the initial phase of large load reductions. These valves open under a sudden reduction in turbine-generator load (in excess of 10%) or a turbine trip.

These valves are also utilized in the pressure control mode during plant startup and plant cooldown. Prior to synchronizing the generator to the grid, the reactor power may be increased up to 10 percent by dumping the steam to the condenser. This will facilitate establishing the minimum turbine-generator load (5-10%) without placing a step-load demand on the reactor system. The dump valves close automatically as steam is admitted to the turbine. During plant cooldown, steam is dumped to the condensers to provide a heat sink rather than to atmosphere through the atmospheric dump valves. This conserves condensate in the system.



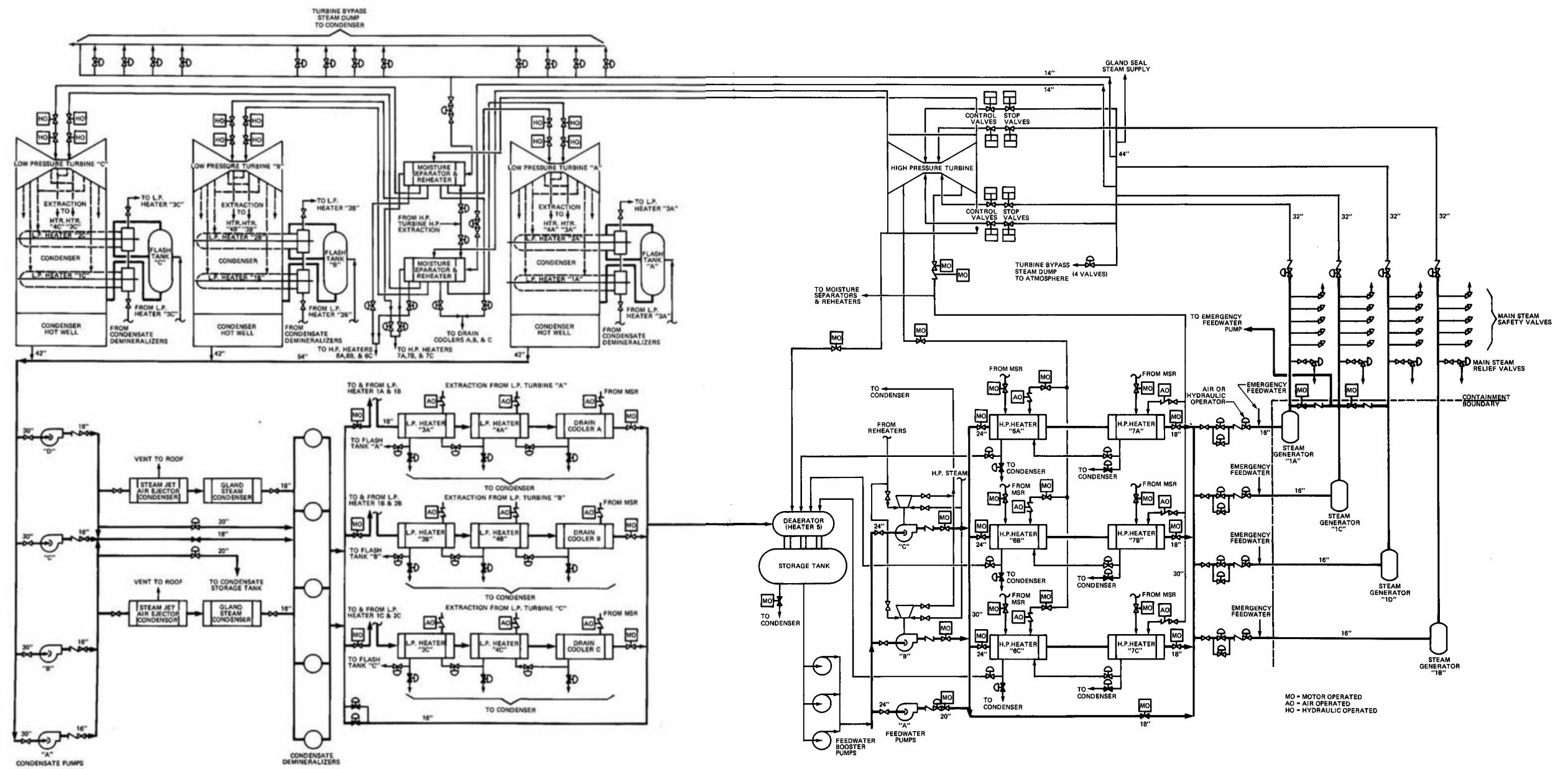

Figure 15.3-1. Typical Steam, Condensate and Feedwater System, Flow Diagram

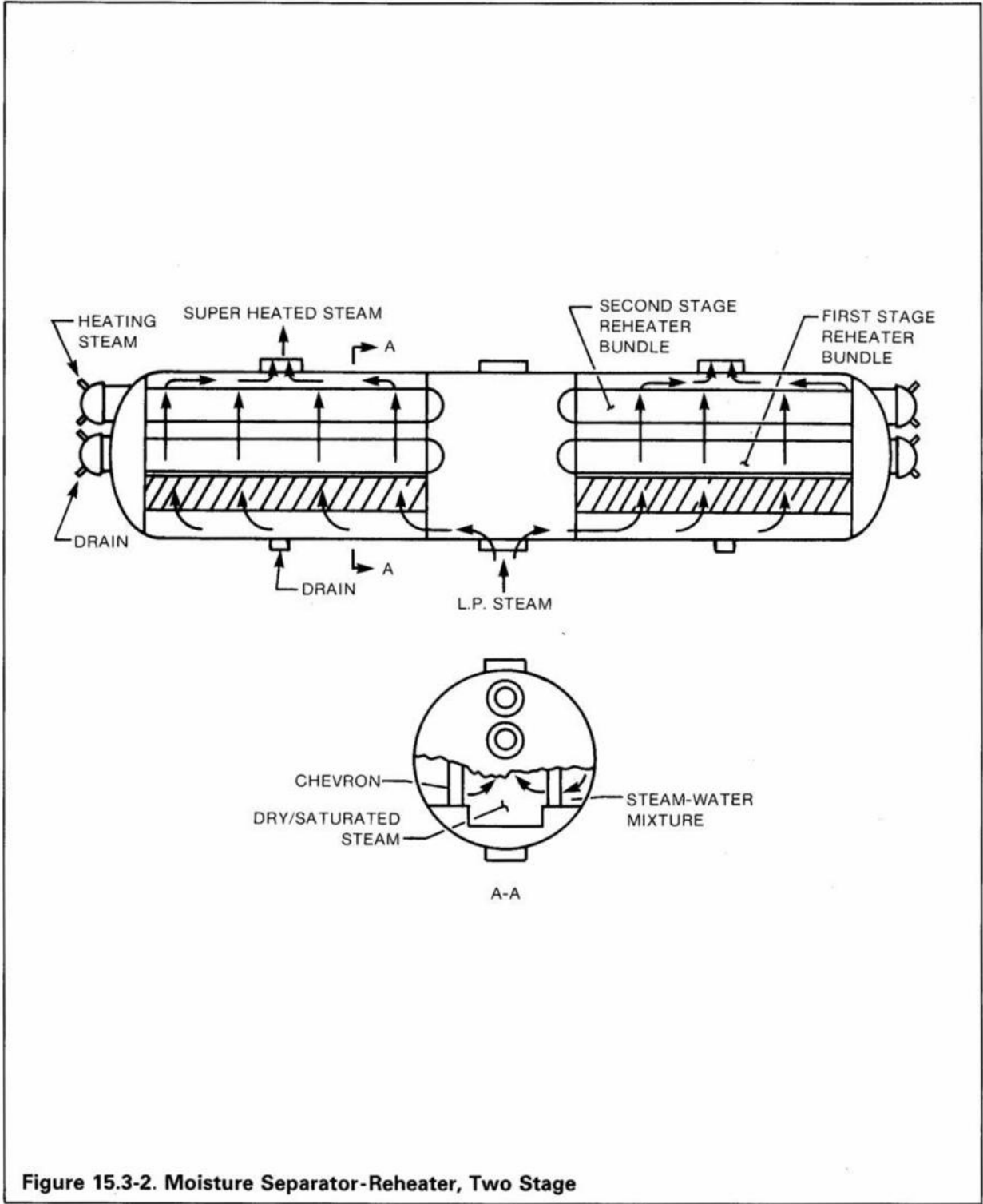

Figure 15.3-2. Moisture Separator-Reheater, Two Stage

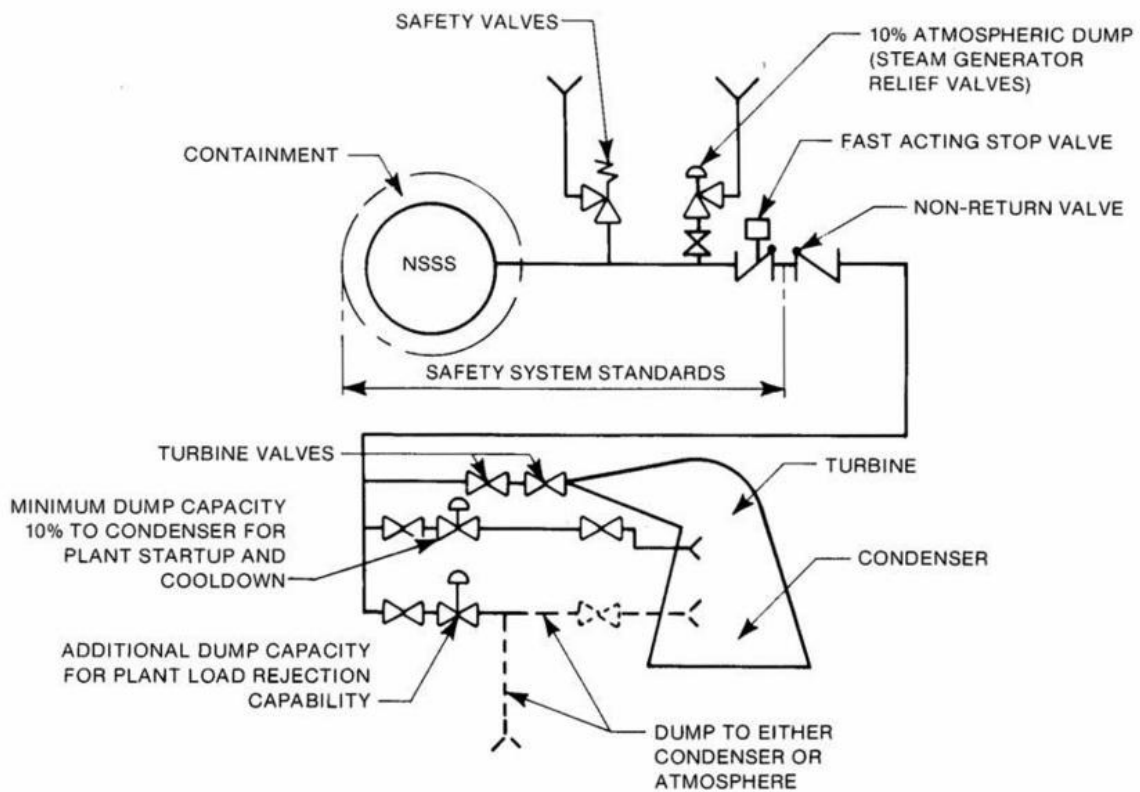

Figure 15.3-3. Steam Dump System, One-Line Diagram



# chapter 15.4

## feedwater heating system (turbine)

### FEEDWATER HEATERS

The Feedwater Heating System (Figure 15.3-1) is of the closed-loop type with deaeration accomplished in the condenser hotwell and a separate, open deaerating feedwater heater. The condensate pumps take suction from the condenser hotwell and pump condensate through the air ejector condensers, the gland steam condensers, the condensate polisher, and four stages of low-pressure feedwater heaters to the deaerator. The feedwater booster pumps draw suction from the deaerator water storage tank, which is mounted directly below the deaerator, and supply the main feedwater pumps. The water discharge from the feedwater pumps flows through two stages of high-pressure heaters then into the steam generators. Typically the feedwater heaters are one-third-size units arranged in three parallel trains. Each train of low-pressure feedwater heaters is provided with motor-operated shut-off valves. There is usually a single bypass sized to handle the flow of one low-pressure feedwater heater train. Each high-pressure feedwater heater train is also provided with motor-operated isolation valves and a single bypass sized to handle the flow through one feedwater heater.

### CONDENSATE PUMPS

There are four one-third-capacity centrifugal condensate pumps shown with motor drives and common suction and discharge headers. Each condensate pump is driven by a single motor. Three pumps are normally in operation.

### FEEDWATER AND FEEDWATER BOOSTER PUMPS

Three one-half capacity feedwater pumps are shown with common suction and discharge headers. Two pumps are turbine driven with hot reheat steam and, in this case, the third pump and the booster pumps are motor driven. The motor-driven feedwater pump may be used for startup and as a reserve or standby pump, although a small startup feedwater pump (not shown) is recommended for startup and shutdown. The discharge from the pumps is automatically recirculated back to the deaerator whenever the flow to the high-pressure feedwater heaters falls below the minimum. The pump starting circuits are interlocked to prevent starting unless the recirculation control valves are open. Minimum feedwater pump suction pressure protection is provided through automatic starting of a feedwater booster pump.

Feedwater flow to each steam generator is controlled by a feedwater regulator in each feedwater line. The regulator is controlled by steam generator level, steam flow and feedwater flow. A signal from the Feedwater Control System also sets the speed of the turbine-driven main feedwater pumps and the position of the motor-driven feedwater pump discharge control

valve so as to maintain the main feedwater regulators within their control range. This setting allows the system to accommodate all operating conditions automatically and provides control margin to accommodate load transients.

### **FEEDWATER HEATER DRAINS**

Drains from the high-pressure feedwater heaters are routed to the deaerator. Drains from the four

low-pressure feedwater heaters are cascaded back to the condenser. Drains from the moisture separator-re heaters are routed to the various points in the feedwater heating train, based on energy content.

# chapter 16

## plant operation

This chapter, which presents a summary of the overall operation and maintenance of a four-loop Nuclear Steam Supply System (NSSS), also supplements and integrates the individual system operating descriptions. Descriptions are not totally complete as actual plant operating procedures are specific to the plant, detailed and lengthy.

## STARTUP

Startup, as presented here, applies to routine plant operation startup.

Startup procedures depend upon the plant conditions that exist at the beginning of the operation. There are two types of startup: cold and hot. The following tabulation defines the major differences between the initial conditions of each startup type:

Parameter	Cold	Hot
Reactor coolant temperature, °F (°C)	<140 (60)	557 (292)
Reactor coolant pressure, psig (bar)	400 (28)	2235 (155)
Pressurizer level, percent full	100	25
Pressurizer temperature, °F (°C)	140 (60)	651 (344)

Startup from a cold condition is initiated following a shutdown that required the Reactor Coolant System (RCS) to be cooled down and depressurized, such as during refueling. Startup from a hot condition refers to a return to power operation following a shutdown not requiring depressurization of the RCS, such as a restart following a turbine trip.

Estimates of times required for typical startups from both of these initial conditions are presented in Table 16-1.

## Cold Startup

Cold startup is described first because the steps involved in the advanced stages of both types of startup are similar. In performing a cold startup, the initial step is to conduct precritical checks and to line up the electrical and fluid systems. Checks are made to assure that electrical power is available to all components and systems required to operate during startup and normal plant operation; that all instrumentation and control systems have been calibrated or tested and are functioning properly; and that the fluid systems are valved in as required.

After completion of the pre-criticality checks, the various systems are lined up as follows:

- The RCS and pressurizer are completely filled with borated water and the system pressure is maintained by charging and letdown flow control.
- The Chemical and Volume Control System (CVCS) is filled with water at the same boron concentration as the RCS. The volume control tank level is within the normal operating range and the tank is pressurized with nitrogen or hydrogen. The reactor coolant makeup is automatically controlled and the boron concentration properly adjusted.
- The Component Cooling Water System is in service, supplying cooling water to the NSSS systems.

- The Safety Injection System is lined up for operation, with the initiation signal manually blocked and accumulators isolated.

All pressurizer heaters are energized to start the heatup of the pressurizer necessary to form the steam bubble. When the pressurizer fluid reaches saturation temperature for the pressure being maintained, steam formation in the pressurizer begins. Flow in the letdown line is increased by the operator to lower pressurizer level to the normal range of 20 to 80 percent in preparation for the plant heatup.

Reactor coolant pumps are started sequentially and pump heat is used to raise the RCS temperature. The Residual Heat Removal

System (RHRS) equipment, if in service, is shut down. Samples of primary and secondary coolant are drawn and analyzed to assure that water chemistry is within allowable limits. Hydrazine is added, as necessary, for oxygen scavenging prior to reaching 180°F (82°C) primary side temperature.

The charging pump speed is reduced to the value necessary for minimum allowable reactor coolant pump seal injection flow. RCS pressure is maintained by adjustment of the pressurizer heaters and/or pressurizer spray. When the pressurizer water level reaches the no-load setpoint, the letdown flow rate is reduced and the charging pump is switched to automatic control.

**TABLE 16-1  
ESTIMATED STARTUP TIME IN HOURS REQUIRED BY NSSS**

Operation	Hot*	Cold**
1. Raise primary system pressure to 400 psig (28 bar) and raise pressurizer temperature to saturation at 400 psig (28 bar).	–	6.5
2. Drain pressurizer to no-load operating level, maintaining system pressure at 400 psig.	–	2
3. Withdraw rods to criticality and raise output to power range level.	0.5	0.5
4. Raise RCS to no-load conditions (Tavg = 557°F, (292°C) system pressure 2250 psia (155 bar)).  Secondary plant operations, such as drawing a vacuum in the main condenser and rolling the turbine, can be done before the RCS reaches no-load conditions	–	3.5
5. Raise the NSSS output to full power (5 percent per minute)  The loading rate is restricted by turbine considerations. The cold startup time given above represents the NSSS capability.	0.5	0.5
Total	1.0	13.0

\* Hot – 557°F (292°C) RCS temperature, 2250 psia (155 bar), no-load pressurizer level.

\*\* Cold – Less than 140°F (60°C) RCS temperature, 140°F (60°C) in "water solid" pressurizer.

Prior to plant heatup above 200°F (93°C), compliance with the plant Technical Specifications is verified. This assures that critical plant equipment is in service or available. Two examples are: containment integrity is verified and containment is secured; auxiliary feedwater is verified operable prior to steam generation on the secondary side.

When the reactor coolant temperature increases to about 210-220°F (90-105°C), the steamline vents are closed and the secondary side of each steam generator is drained to the normal operating range.

Primary plant heatup rate is limited to 50°F (28°C) per hour. As the reactor coolant temperature increases, operation of pressurizer heaters and spray maintains the system pressure in accordance with the applicable temperature-pressure curves. Prior to plant heatup above 350°F (177°C), Technical Specifications are again checked and systems such as emergency core cooling systems are completely verified to be available for service. Before raising primary system pressure above 1900 psig (132 bar), steam generator pressure must be greater than 585 psig (41 bar) or a low steamline pressure safety injection will occur.

When the reactor coolant temperature exceeds 400°F (204°C), steam is drawn from the steam generators to warm up the secondary plant, develop a vacuum in the main condenser, and roll the turbine. Conventional condensate and feedwater systems startup procedures would be followed.

The RCS heatup and pressurization continues until a no-load coolant temperature of approximately 547°F (286°C) and a primary pressure of 2250 psia (155 bar) are reached.

Primary temperature is maintained through the balanced use of reactor coolant pump heat input and a steam dump system which releases steam to the main condenser. Steam pressure is held at the saturation pressure which corresponds to the no-load reactor coolant average temperature (Tavg) value. At this point the plant is in the hot standby condition.

### **Startup from Hot Standby**

The shutdown banks of the reactor control rods are withdrawn. A corresponding boron concentration is calculated so that reactor criticality will occur at a selected control bank position above the rod insertion limit. The higher the boron concentration, the further the control rods must be withdrawn to achieve criticality. Control rods must be pulled above a certain height, the rod insertion limit, so that in the event a trip occurs the full insertion of the rods will add at least a prescribed amount of negative reactivity. If the rods are initially too far in, the amount of negative reactivity added may be too small. A boron dilution is started to bring the boron concentration to the estimated critical concentration.

The control rod banks are then manually withdrawn to achieve criticality while observing proper bank overlap, rod position indications, and nuclear instrumentation. When control rod motion is not in progress, a steady-state startup rate of 1.0 decades per minute should not be exceeded. Evidence of criticality is indicated by a positive sustained startup rate with no rod motion and increasing source range counts. After criticality is achieved and reactor physics critical data has been taken, reactor power is raised to the point where significant heat generation occurs, about 1 percent power. This is evidenced by an increasing primary Tavg with the steam dump valves automatically opening as

needed to hold steam pressure at a set constant value. Auxiliary feedwater flow is manually increased to maintain a steady value of steam generator water level.

With a positive startup rate established as reactor power enters the power range, the reactor core heats up causing a major physics effect known as the "power defect" which decreases the reactivity of the core and causes reactor power to level off at a 0 decades per minute startup rate. To reach 100-percent power, a boron dilution is needed to counteract the power defect.

Before reaching the flow capacity of the auxiliary feedwater system, equivalent to about 3.5-percent steam flow, the steam generators feedwater supply is switched to the main feedwater system; the auxiliary feedwater system is secured and lined up for safeguards actuation.

Control rods are manually withdrawn to raise reactor power to about 6-15 percent. The turbine-generator is brought up to synchronous speed and paralleled on the grid. As turbine-generator loading is commenced, the steam dump valves will ramp shut at a rate that maintains steam pressure until they are fully closed.

Pressurizer heater and spray valve control is placed in automatic operation. Control rod motion for RCS temperature control and feedwater valve control both remain in manual operation until the plant auxiliaries have been transferred to the main generator output. After determining that all systems are functioning properly at the initial load, the reactor is switched to automatic control and plant loading is continued to full power at a rate not to exceed 5 percent of full power per minute.

Major electrical loads are transferred from the system auxiliary transformer to the unit auxiliary transformer supplied by the turbine-generator. Auxiliary equipment loads on the critical safety buses are not transferred.

## **NORMAL OPERATION**

During normal steady-state and transient operation, important plant parameters are controlled by the NSSS control system. The rod control system automatically controls RCS average coolant temperature ( $T_{avg}$ ) as a programmed function of turbine load. After large load decreases, the steam dump control system augments the rod control and helps minimize temperature swings while bringing the plant to the new temperature in a stable, controlled manner. RCS operating pressure is maintained by several forms of pressure control equipment (including pressurizer heaters, spray, and relief valves), all under the pressurizer pressure control system. The pressurizer level control system adjusts charging flow from the CVCS to maintain pressurizer level at a programmed value which varies with RCS average coolant temperature. The steam generator level control system maintains the proper inventory in each steam generator by means of feedwater flow control valves.

Reactor power is maintained equal to load by virtue of feedback effects inherent in the physics of a PWR. The rod control system also has some effect on power during transients.

An additional concern during power operation is the axial power distribution in the core. Normally this is controlled so that the power distribution closely approximates that of an unrodded core at full power. This ensures acceptable fuel burnup distributions and guarantees that no severe



xenon oscillations are initiated. [Xenon oscillations can occur when the power distribution is skewed to one end of the core. After several hours the xenon-135\* concentration builds up in the end of the core. Xenon-135 is a strong neutron absorber and hence, the power distribution is forced to the opposite end of the core. Xenon then builds up there while the original xenon decays, and the process reverses.]

Power distribution is controlled by adjusting the RCS boron concentration which results in control rod movement, thus affecting the power distribution. In plants with the Integrated Control System the boron adjustments are done automatically.

## SHUTDOWN

This subsection describes the plant operations necessary to take the plant from power operation to either of the shutdown conditions previously described (cold or hot).

Assuming the plant is operating at some power level in excess of 15 percent, the initial step in shutdown is to unload the turbine-generator. In doing so, control systems are monitored to assure that the RCS coolant average temperature is reduced automatically in accordance with the programmed changes, and that steam generator levels are automatically maintained in the proper range.

As the reactor power level approaches house load level, reactor control and steam generator water level control are transferred to manual operation. Station electrical loads are transferred

from the turbine-generator supplied transformer to one supplied by the off-station grid. The turbine-generator is then completely unloaded, disconnected from the main grid, and taken out of service in accordance with the turbine-generator instructions.

If the plant is to be placed in a subcritical hot standby condition, the control rods are inserted to reduce power level and the secondary systems are placed in a hot standby condition. In this operational mode a maximum of two out of four reactor coolant pumps (RCPs) may be secured. Proper loop flow and desired loop temperatures are maintained with the other RCPs until the Residual Heat Removal System (RHRS) is in service.

Steam dump is utilized initially to remove residual heat. If the plant is to remain in this condition for some period of time, changes in boron concentration may be required because of xenon transients.

If the plant is to be taken to the cold shutdown condition, boration is initiated to bring the boron concentration to the cold shutdown value. Samples are taken periodically to follow the increase in boron concentration and verify proper shutdown margin.

With the control rods inserted, the reactor is shut down. Pressurizer level is raised in anticipation of coolant contraction during the cooldown. Makeup water at the cold shutdown boron concentration is used to maintain pressurizer level above the no-load value during the cooldown. Steam dumps are adjusted to start a 50°F/hr (28°C/hr) cooldown rate.

All pressurizer heaters are turned off and the spray valves are controlled manually to cool the

---

\* Produced via iodine-135, Xenon-135 is a fission product with a 6.7 hour half-life.

pressurizer at a sufficiently slow rate to maintain the system pressure within the applicable pressure-temperature limits. To provide spray flow a RCP must be operating in one of the two loops with spray flow connections.

Prior to reaching the automatic safety injection setpoints during cooldown and depressurization, the safety injection initiation signals are blocked. Before reaching the pressure when the safety injection accumulators would discharge, the accumulator isolation valves are closed.

As steam generator steam pressure decreases during the cooldown, the steam dump must be re-adjusted to maintain a 50°F (28°C) per hour cooldown rate. When RCS temperature and pressure are less than 350°F (177°C) and approximately 400 psig, respectively, the RHRS is placed in operation to maintain the desired cooldown rate.

As the steam generator steam pressure approaches zero psig, the steam dump valves are closed. When the reactor coolant reaches 200°F (93°C), the steam sides of the steam generators are filled to the vents for wet layup. Chemicals are added to the steam side as required.

After assuring that the boron concentration is at the proper cold shutdown value, the remainder of the control rods are inserted. Reactor coolant pumps are run only as needed to assure uniform loop cooldown and to provide spray for pressurizer cooldown.

When the reactor coolant shutdown temperature is reached, operating equipment of the RHR and component cooling systems are reduced to the minimum required to maintain temperature.

Pressurizer heaters are operated manually to maintain the desired pressure.

Charging flow is throttled to control pressurizer cooldown rate and raise pressurizer level using auxiliary spray since normal spray is not available when reactor coolant pumps have been secured. Pressurizer pressure is also controlled by auxiliary spray while a steam bubble exists in the pressurizer.

If the pressurizer is filled solid, rapid rises in primary system pressure can occur due to small inputs of water mass or heat. Solid plant primary pressure control utilizes a pressure control valve between the RHR and CVC systems which is set to maintain a selected pressure while charging makes up for any coolant contraction and losses.

Purification of the primary system using the CVCS demineralizers is continued using forced flow from the RHRS. Very little letdown flow is possible through the normal letdown flow path at low primary system pressures due to the low differential pressure across the CVCS letdown orifices.

The time required for plant cooldown is approximately 20 hours (based on 95°F (max) cooling water to the residual heat exchangers).

## **MAINTENANCE**

### **Preventive Maintenance**

Maintenance of the Westinghouse PWR Nuclear Steam Supply System is treated in two broad categories: preventive maintenance and corrective maintenance. A well planned and actively pursued program of preventive maintenance will minimize the need for corrective maintenance.

The major items of preventive maintenance pertain to the major components of the RCS: the reactor vessel, reactor coolant pumps, steam generators, pressurizer, control rod drive mechanisms, and instrumentation. Maintenance of the reactor vessel principally consists of monitoring the effects of neutron irradiation and periodic inspections for the emergence or growth of flaws.

The effect of neutron irradiation on the physical properties of the vessel materials is of primary concern in reactor vessel operation. The reactor vessel is provided with specimen capsules, located between the neutron shield pad and vessel wall opposite the center of the core. The capsules contain tensile Charpy V-notch and wedge-opening-loading specimens taken from the reactor vessel shell plates and associated weld metal and heat-affected zone. Dosimeters and thermal monitors are included to permit evaluation of the neutron flux and temperatures experienced by the specimens. The effects of neutron irradiation on the material properties can be determined by comparing test data from the specimens removed periodically during refueling shutdowns with the unirradiated specimen data provided.

During fabrication a series of radiographs are taken to locate any flaws in the material or welds. Any flaws identified are evaluated and repaired if significant. After completion of fabrication, an ultrasonic inspection of the reactor vessel shell is performed to map the size and location of allowable flaws. This serves as a reference for future in-service inspections to determine if other flaws have developed or if known allowable flaws have increased in size.

Control rod drive mechanism operating coils are checked for coil resistance and insulation resis-

tance on a periodic basis. Pressurizer heaters are subjected to a similar program of testing.

Secondary water chemistry is carefully maintained at all times to minimize corrosion effects throughout the systems and particularly in the steam generator. Periodic inspections using eddy current testing to verify steam generator tube structural integrity occur on a rotation basis. All defective tubes are plugged or repaired prior to the RCS being heated above 200°F Tavg. Tubesheet sludge removal through the use of high-pressure water jets is a frequent preventive maintenance item done to reduce corrosion and improve heat transfer.

The steam generators are designed with manholes on both the inlet and outlet sides of the primary channel head to provide access should tube plugging become necessary. The shell side has hand holes just above the tube sheet to facilitate inspection, and two manholes above the top of the tube bundle through which all moisture separation and steam drying equipment can be dismantled, removed, and replaced if necessary.

For the reactor coolant pumps, the recommended maintenance on seals is to inspect the No. 1 seal at each refueling during the first two or three years of plant operation. Based on these inspections a program of periodic inspections for the No. 1 seal can then be instituted.

At every third refueling shutdown, the reactor coolant pumps No. 2 and No. 3 seal rings and runners may have to be replaced since these are rubbing face type seals with a design life objective of 20,000 hours of operation.

Reactor coolant pumps are designed such that the seals may be inspected and replaced without draining the RCS and thus this maintenance can be done in parallel with refueling operations. A machined shoulder on the pump shaft just below the radial bearing backseats against the thermal barrier housing when the pump shaft is disconnected from the motor and lowered. The backseat is capable of withstanding a static head of 30 feet of water.

Auxiliary system components require the usual preventive maintenance such as adjusting or replacing valve packing, lapping or replacing valve seats, inspection or replacing pump bearings, packings and seals, and so on.

### **Corrective Maintenance**

Because the type and frequency of corrective maintenance will depend on the quality of the preventive maintenance program, the treatment of this subject will be limited to the features of the plant that contribute to the ease of maintenance.

Control rod drive mechanisms can be removed, if required, without unloading the core, and the drive coils can be removed without breaking the pressure boundary of the RCS.

The pressurizer is designed for easy access to the heater terminal connections and wells. A manhole is also provided for internal access to facilitate inspection or replacement of the spray nozzles if required.

The reactor is designed so that the core and all internals can be completely removed. This provides necessary access for periodic inservice inspections of the reactor vessel.

An added feature of primary importance to maintenance is the fact that in the PWR the inherent separation of reactor and steam systems eliminates radioactivity in the steam systems, turbine, condensate system, and feed systems. This eliminates the need: to remove cumbersome shielding before performing maintenance on these systems; to perform maintenance in the cramped quarters resulting from permanent shielding walls; and for special clothing, radiation monitoring, personnel time limits, etc. required while working in a radioactively contaminated environment.

### **LOAD FOLLOW CAPABILITY**

The NSSS and its control system is designed to the following basis:

1. The NSSS is capable of following repetitive load changes automatically throughout the range of 15 percent to 100 percent of rated power consistent with the cyclic nature of the utility system load demand. This capability exists throughout the life of the core.
2. The NSSS is capable of automatically making step changes in load of 10 percent of rated power and ramp changes of 5 percent of rated power per minute.
3. The NSSS is capable of following a reference 12-3-6-3 daily load cycle consisting of 12 hours at full power, decreasing load to 50-percent power over a 3 hour period, remaining at 50-percent power for 6 hours and returning to full power over a 3 hour period. This load cycle can be followed daily through all of the fuel cycle.

4. The NSSS has a reserve capability of returning to full power at the design ramp rate at any time during the reference daily load cycle through at least 85 percent of the equilibrium fuel cycle (i.e., minimum burnup of 11,000 megawatt days per metric ton of uranium).
5. The NSSS is capable of accepting a 50-percent load reduction from rated power without reactor trip. This capability is based upon the ability of secondary plant systems to accept 40-percent steam dump while maintaining adequate feedwater supply to the steam generators. The additional 10-percent power decrease is accomplished by rod control.
6. The NSSS is capable of accepting complete load rejection from the maximum rated power level with reactor and turbine trip.

As an option, the NSSS can be designed to accept complete load rejection from rated power without reactor trip and to continue producing the power required by the station auxiliary systems. This optional capability is based on the ability of secondary plant systems to accept 70- to 85-percent steam dump and to maintain adequate feedwater supply to the steam generators.

## LOAD FOLLOW FEATURES

Advantages of the Westinghouse method of load follow control include both ease of operation and the flexibility for making varied load changes. The ease of load follow operation is achieved by the reactor control system which moves control rods automatically.

The plant operator makes boron concentration adjustments to maintain full reserve capability, while maintaining axial flux difference in the target band. The operational flexibility of the PWR permits follow of any load cycle without being restricted to the reference cycle or pre-programmed daily load cycles. Even in an extended fuel cycle (the fuel cycle extended by operation at a lower power beyond the design end of life) the plant still is capable of load changes between 15 percent of rated power and the achievable power level during the period of extended operation.

## LOAD FOLLOW OPERATION

Load changes on a Westinghouse nuclear power station are initially made on the turbine-generator. The control system of the NSSS then adjusts the power level of the reactor to follow the power demand of the turbine. The Westinghouse PWR control system is designed to provide simple operation and a high degree of flexibility for responding to load changes. Reactivity changes required to maintain or change the power level of the reactor are made by control rods which are automatically moved in symmetric groups by the reactor control system.

During operation in the power range, the control rods maintain  $T_{avg}$  with reactor power following steam demand/turbine power. At a steady-state turbine power, stepping control rods out will initially raise reactor power. With reactor power being greater than steam demand, primary coolant  $T_{avg}$  will rise adding negative reactivity to counteract the positive control rod reactivity added when the rods were stepped out. This results in reactor power matching steam demand and higher  $T_{avg}$ .

Additional capability for load follow is through the use of the Boron Thermal Regeneration System (BTRS) which is described in Chapter 4.2. BTRS provides a means for varying boric acid concentration without the generation of large volumes of liquid to be processed.

## **DAILY LOAD FOLLOW**

### **Operation With Boron Adjustment**

In the normal mode of operation for following the reference load cycle, the plant maintains full reserve capability for returning to full power at the design ramp rate of 5 percent per minute at any time during the load cycle over the greater part of the fuel cycle. This capability is maintained by automatic adjustment of the boron concentration to compensate for xenon reactivity changes, thereby keeping the control rods within its axial flux distribution (AFD) target band. Following the power level change made by the control rods, the control system makes boron concentration adjustments whenever the control rods approach the limits of their AFD target band. Alternately, the plant operator can input an anticipated load pattern to the plant computer. The control system then calculates the desired change in boron concentration, the time the change should be made, and initiates the operation which sets the charging flow of the feed solution, and the total quantity of solution required to make the desired concentration change. A flow integrator control automatically shuts off the makeup flow when the desired change is complete.

The boron concentration changes for the reference load cycle can be made for at least 85 percent of an equilibrium fuel cycle with the Boron Recycle System (BRS). Beyond 85 percent of fuel cycle life, the quantity of reactor

coolant effluent resulting from the boron concentration change would exceed the capacity of the boron systems.

During the last 15 percent of the fuel cycle, the time it takes to achieve full power from the 90-percent level is determined by the xenon "burnout" rate and typically requires 2 to 4 hours.

### **Operation Without Boron Adjustment**

Not all load changes require boron adjustment. Boron concentration changes during plant operation are required whenever axial flux difference would extend outside the allowable target band, whenever control rods need to be withdrawn back above the rod insertion limit, or to overcome "power defect" during power ascension and unloading.

For a power increase, without using boron dilution to overcome the negative reactivity added by the power defect, the control rods would step out to maintain  $T_{avg}$  until the rods were completely withdrawn from the core. From this point on with a continuing increase in power,  $T_{avg}$  will drop adding positive reactivity to maintain reactor criticality.  $T_{avg}$  will continue to drop until turbine loading is stopped either by manual operation or automatically upon reaching the low  $T_{avg}$  deviation setpoint signal.

The reference 12-3-6-3 daily load cycle can be followed throughout the fuel cycle by control rods alone, without boron adjustment. Operation in this manner has the advantage of eliminating reactor coolant effluent associated with daily load follow. However, daily load follow operation by this method does not provide for full reserve capability.



## FULL LOAD REJECTION CAPABILITIES

The NSSS can be provided with the capability to sustain sudden large load decreases, up to and including a rapid transient from full load down to plant auxiliary loads, concurrent with the loss of external power. This is principally accomplished by controlled dumping of turbine throttle steam either directly to the main condenser, or to the main condenser and atmosphere. Control system response and allowed changes in RCS parameters also contribute to this capability.

The steam dump serves as a short-term artificial load which allows the reactor control system time to automatically cut back power. Normally, the reactor control system itself is not rapid enough to follow a sudden complete loss of load without having certain reactor plant variables, (e.g., pressure and temperature) exceed allowable operating limits. Therefore, unless a sufficiently large controlled steam dump capable of simulating an external load on the reactor is used, the reactor will automatically trip and shut down the plant.

The incorporation of an adequately sized steam dump system permits rapid automatic reduction of core power without reactor trip and enables the plant to continue operation and supply power for its own auxiliaries. This capability could be of critical importance in the event of large grid system disturbances.

Steam dump is controlled by signals from the RCS (essentially reactor coolant average temperature), and is reduced as rapidly as the reactor control system reduces core power by inserting control groups of control rods. With this system, the total quantity of steam dumped is minimized since the steam dump is decreased as rapidly as conditions permit.

The capacity of the steam dump initially required is equal to the total full load steam flow, less the 10-percent step load change for which the reactor control system has been conservatively designed, less the equivalent steam for an allowed rise in reactor coolant system temperature and pressure, less the steam required by the turbine to carry auxiliary loads. This results in a maximum steam bypass flow requirement of approximately 70 to 85 percent of rated steam generator flow. The integrated flow is equivalent to approximately 8 to 10 full power minutes.

The feedwater system is designed to ensure that feedwater flow to the steam generators during the transient is sufficient to maintain the level within limits.

## PLANT EMERGENCY RESPONSE

Nuclear power plants contain integral safety features which function automatically. Selected process parameters generate automatic reactor and turbine trip signals. Upon receipt of a reactor or turbine trip signal, a first out annunciator light flashes in red with an accompanying sound (horn, bell, etc.) alerting the operators to the initiating trip signal.

Whenever a reactor trip occurs, the reactor trip breakers open and all control and shutdown rods are fully inserted. The turbine and turbine-generator will trip off the line with house loads automatically transferred to the offsite sources of power. Reactor coolant pumps supplied from the offsite electrical source will maintain forced flow cooling to the reactor core.

If offsite power is not available, the long coast down times of the reactor coolant pumps assures adequate flow during the power decay

transient. The coast down time is prolonged by the heavy flywheel mounted above the motor.

The steam dump system will actuate if necessary and restore Tavg to the no-load value. Pressurizer pressure will recover as pressurizer heaters automatically energize. Pressurizer level will recover to the no-load value as the charging pumps make up for the plant cooldown following the reactor trip.

In the event of a fault or failure posing some hazard to the plant's integrity, emergency systems are automatically initiated to provide the necessary cooling water supply to the reactor

core, to seal the containment building, and to limit any pressure increases within the containment. The provision of fully redundant systems and the physical and electrical separation of these systems provides assurance that the necessary protective functions will be accomplished.

If conditions occur which result in a loss of normal electrical power to a safeguards electrical bus, backup emergency diesel generators are automatically started and necessary equipment will be automatically sequenced on the buses to safely cool down the primary plant if required.



# **chapter 17**

## **safety conderations**

The philosophy employed in the safety design of a Westinghouse PWR is described as "defense in depth." Defense in depth ensures that a plant is designed, fabricated, constructed, and operated not only to be safe during normal operation but to account safely for the possibility of a spectrum of accidents. The plant has sophisticated safety systems and devices to guard against human error, equipment failures, and malfunctions taking into account such natural phenomena as earthquakes, tornadoes, and floods.

### **FIRST LEVEL OF DEFENSE**

The first level of defense addresses prevention of accidents through the design of the plant, including quality assurance, redundancy, separation, testing, and inspection. The plant is designed and built to operate as intended with a high degree of reliability. An example of how this first level of defense is applied is the design of the reactor coolant system (RCS) pressure boundary. This same philosophy is utilized in the design of all safety-related systems, components, and structures.

The components that comprise the RCS pressure boundary are required to be designed, fabricated, erected, and maintained to quality standards that reflect the importance of the safety function to be performed. The quality standards provide that the facility will be able to withstand, without loss of capability to protect the public, any additional forces that might be imposed by natural phenomena such as earthquakes, tornadoes, flooding conditions, winds, ice, or other local site factors. A comprehensive Quality Assurance Program confirms that specific requirements are met during the various stages of design, fabrication, construction, and operation. All components of the RCS pressure boundary are designed, fabricated, inspected, and tested to conform with or exceed

the requirements of Section III of the ASME Boiler and Pressure Vessel Code. The RCS pressure boundary is designed as Seismic Category 1 to provide a design margin to ensure the capability to perform its function under the conditions of the largest potential ground motion or other severe natural phenomena at the site. The U.S. Nuclear Regulatory Commission (U.S. NRC) has reviewed and specified use of the ASME Code for nuclear plants. Additionally, the U.S. NRC audits the actual methods used for design, analysis, fabrication, construction, and testing.

The U.S. NRC requires that special consideration be given to static and dynamic loads, temperature, and irradiation effects that components might be subjected to during their service lifetime. Included are requirements for safety margins to protect against unexpected internal loadings, undetected internal flaws, and changes in material properties. The RCS pressure boundary is capable of accommodating, without exceeding stress limits, the static and dynamic loads imposed as a result of anticipated operational occurrences and design basis accidents. Credible transients which could cause pressure surges have been conservatively designed for by reactor protection system trips and by incorporation of relief and safety valves. In addition to these considerations, reduction of the probability of a rapidly propagating-type failure is accomplished through provisions for control over service temperature and irradiation effects.

Close control and inspection over the selection of RCS pressure boundary materials and the fabrication of RCS pressure boundary components are exercised. Provisions are made for inspections, testing, and surveillance of critical areas of the pressure boundary to assess the structural and leaktight integrity during its service lifetime. Materials and components of

the RCS are subjected to thorough nondestructive inspection prior to operation and a pre-operational hydrotest is performed at 1.25 times design pressure. Provisions have been made for periodically inspecting, in situ, all areas of relatively high service factors in accordance with ASME Section XI in order to discover potential problems before significant flaws develop. A reactor vessel material surveillance program is employed utilizing test samples which are placed in the reactor vessel and irradiated for designated periods of time, removed, and examined to determine changes in material properties.

Also, RCS water chemistry control protects against corrosion which otherwise might reduce structural integrity during service lifetime. For pipes of the size, thickness, and material used in the RCS, detectable leakage will occur before a major rupture of the pipe.

The RCS pressure boundary is conservatively designed to accommodate the system pressures and temperatures attained under all expected modes of plant operation, including anticipated transients and abnormal loading conditions, such as seismic conditions, and to maintain the stresses within appropriate stress limits. The RCS pressure boundary is protected from overpressure by means of pressure-relieving devices as required by the ASME Boiler and Pressure Vessel Code, Section III.

## **SECOND LEVEL OF DEFENSE**

Despite the care taken at the first level of defense, it is prudently anticipated that some failures or operating errors could occur during the life of a plant with the potential for safety concern. Accordingly, a second level of defense is provided by means of reliable protections

systems, designed to assure that expected occurrences and off-normal conditions will be detected and either arrested or accommodated safely. The requirements for these protection systems are based on a consideration of a spectrum of events that could lead to off-normal operations. Extensive testing programs are carried out to verify that the protective systems will function adequately.

An example of a second level of defense system is the reactor protection system. The reactor protection system is activated by redundant and independent instrument channels which translate their respective signals into redundant logic channels to automatically initiate a protective action. Conservative design practices, adequate safety margins, inspectability, and redundant detection and actuating equipment are incorporated in protection systems to assure effectiveness and reliability. In addition, these systems are designed to be monitored and tested routinely to assure that they will operate reliably if and when required.

The reactor protection system is designed to meet the requirements of the U.S. NRC General Design Criteria and conforms to IEEE279 "Standard Nuclear Power Plant Protection Systems." The reactor protection system is designed to a high degree of reliability and testability to prevent or suppress conditions that could result in exceeding acceptable fuel limits. Protection and operational reliability is achieved by providing redundant instrument channels for each protective function.

U.S. NRC regulations require that sufficient redundancy be provided to allow individual channels to be calibrated and tested with the reactor at power and to allow the reactor protection function to be completed even if one

channel is in test and one other channel fails to trip. These redundant channels are electrically isolated and physically separated from one another.

The basic reactor operating design defines an allowable operating region of power, reactor coolant pressure, and reactor coolant temperature conditions. If the reactor protection system receives signals which are indicative of an approach to operating conditions outside of the allowable operating region, the system actuates alarms, prevents control rod withdrawal, initiates load cutback, and/or opens the reactor trip breakers.

The reactor protection system is designed to withstand the effects of the Design Basis Earthquake. Typical protection system equipment is subjected to type tests under simulated seismic accelerations to demonstrate its ability to perform its functions. Should a failure occur, the reactor protection system is designed to fail safe. To meet this requirement, each reactor trip channel is designed on the "de-energize to operate" principle; a loss of instrument power to that channel causes the system to go into its trip mode. To assure that the reactor protection system continues to function properly, the plant Technical Specifications require periodic surveillance, testing, and recalibration of each channel.

### THIRD LEVEL OF DEFENSE

The third level of defense is designed to add further margin by postulating, for design purposes, the occurrence of extremely unlikely circumstances. A hypothetical accident is assumed to occur and to progress beyond that which would be expected and which could occur only in the event of failures in both the first and second levels of defense. This scenario is

studied in detail, with a deliberate compounding of combinations and sequences of events to make the safeguards performance objectives more demanding. From an analysis of these postulated events, a third level of features and equipment is designed and incorporated into the plant to safely control such an unlikely event and to protect the public health and safety.

For example, the emergency core cooling system (ECCS)\* is provided to mitigate the consequences of a loss-of-coolant accident (LOCA) even though the first level of defense makes such an occurrence highly unlikely. The ECCS is designed to comply with U.S. NRC General Design Criteria. The many conservative steps required by these requirements ensures the ECCS a very high probability of successful operations, if and when required.

The primary function of the ECCS is to deliver emergency core cooling in the event that the primary coolant system is accidentally depressurized (i.e., a LOCA). The ECCS limits the fuel cladding temperature below the level allowed by U.S. NRC Regulations so that the core will remain intact and in place, with its essential heat transfer geometry preserved. This protection is afforded for all pipe break sizes up to and including a postulated circumferential rupture and separation of a reactor coolant pipe.

The ECCS employs a passive system of accumulators, in addition to independent high-pressure and low-pressure pumping systems. The passive system of accumulators does not require any external signals or source of power

---

\* The emergency core cooling system (ECCS) is a generic term that encompasses those systems that provide cooling water to the reactor core under emergency or accident conditions.

for its operation. An accumulator is connected to each of the cold leg pipes of the reactor coolant system and provides for the short-term cooling requirements for a large pipe break by injecting borated water when RCS pressure falls below accumulator pressure. Two independent high-pressure pumping systems, each capable of providing the required cooling, are provided for small break protection and to maintain water inventory after the accumulators have discharged following a large break LOCA. Two independent low-pressure pumping systems are provided, each capable of fulfilling long-term cooling requirements. The ECCS is designed with sufficient redundancy and diversity of components such that the failure of any single active component does not prevent the ECCS from fulfilling its mission. For example, the cooling capability of the ECCS would be sufficient to maintain the fuel cladding temperatures below allowable limits even if the failure of any single active component occurred during a major LOCA. Also, no operator action is required to maintain the ECCS capability in the event of a single failure in the system.

To meet other criteria, additional conservative actions have been taken concerning the ECCS. The ECCS and its components have been designed, fabricated, constructed, tested, and inspected under a strict and detailed Quality Assurance Program commensurate with the importance of its safety function. The structures, systems, and components of the ECCS are designated Seismic Category 1 and are designed to withstand, without loss of capability to protect the public, the most severe environmental phenomena postulated to occur at the site with margins for uncertainties in historical data as required by the U.S. NRC. Missile protection is also provided. The ECCS is designed to applicable codes to provide safety

margins to protect against dynamic effects as required by the U.S. NRC. The ECCS equipment has also been designed and fabricated so that it will function without failure under the worst conditions of post-accident temperature, pressure, radiation, and humidity conditions for the length of time required.

The U.S. NRC also requires that a reliable power supply be provided for ECCS operation. This power supply is provided through independent connections to the system grid and a redundant source of emergency power from independent diesel generators installed on site. Sufficient power for operation of the ECCS is provided even with the failure of a single active component, including a diesel generator in each of these separate and independent power systems.

The ECCS is subjected to a thorough inspection and testing program conforming to U.S. NRC requirements. ECCS components are tested both in the manufacturer's shop and after installation to demonstrate performance and reliability. Design provisions facilitate access to critical parts for visual inspection and for nondestructive inspection where such techniques are desirable and appropriate.

The ECCS design permits periodic testing of active components for operability and required functional performance as required by Technical Specifications. The ECCS delivery capability can be tested periodically by recirculation of water to the refueling water storage tank. The system can be tested for operability up to the last isolation valve before the ECCS piping enters the reactor coolant piping. Provisions have also been made to periodically demonstrate proper automatic operation of the ECCS including testing the sequence of the operation and the transfer to alternate power sources.

# **glossary**

## A

**absorber**—A substance that captures neutrons and removes them from further interaction such as with hafnium, boron, cadmium, and silver.

**attenuation**—The reduction in the flux density, or intensity per unit area, with distance from the source. It may be due to absorption, scattering, or both processes.

**axial offset**—A measure of power distribution in the axial direction, obtained by subtracting the power in bottom of core from power at top of core and dividing the remainder by the total core power to obtain a percentage.

**axial power distribution**—The variation in power density (or production) in the core along the vertical length of the fuel assemblies.

## B

**beginning-of-life**—The point of core life when the nuclear fuel is first subjected to significant neutron flux and therefore burnup.

**biological shield**—A screen or wall of an absorbing or attenuating substance, usually water or concrete, which is placed around a reactor to reduce radiation beyond the shields to allowable levels for personnel or equipment.

**burnable poison**—A substance with high neutron capture cross section (e.g., boron) which is purposely put into a fission reactor to influence the long-term reactivity variations and depletes with time as the core generates power.

**burnup**—A measure of fuel utilization expressed as the amount of energy produced per unit weight of depleted fuel (MWD/MTU).

## C

**chain reaction, nuclear**—A self-sustaining series of events occurring when a neutron splits an atom releasing additional neutrons to cause at least one other atom to split in the same way such that the reaction continues.

**chemical shim**—A chemical (e.g., boric acid) which is added to the reactor coolant for the purpose of controlling the reaction rate by absorbing neutrons.

**cold leg**—The reactor coolant return line from the steam generator (where the coolant has given up some of its heat) to the reactor vessel.

**cold shutdown**—A reactor condition in which the coolant temperature has been reduced to 200°F or below and the pressure has essentially been reduced to atmospheric pressure.

**criticality**—The point at which a nuclear reactor is just capable of sustaining a chain reaction; the condition in which the number of neutrons produced is equal to the number of neutrons absorbed.

## D

**departure from nucleate boiling (DNB)**—The point during nucleate boiling at which the steam produced forms an insulating layer over the heater wall surface resulting in a rapid and significant increase in the surface temperature.

**design basis accident**—An envelope of those assumed accidental conditions that if uncontrolled could result in radiological releases from a nuclear power plant. The plant must be designed to account for the effects of these very unlikely accidents.

**design safe shutdown earthquake**—The maximum earthquake that is considered possible at the site conservatively based upon historical geological data. The plant is designed to shut down without danger to the public if this earthquake occurs.

**Doppler effect**—Negative reactivity insertion due to an increase in non-fissioning neutron absorption by fuel. The effect results from an increase in fuel temperature, which increases the absorption cross section of fuel.

## E

**end-of-life**—The point in core life when burnup has depleted the nuclear fuel to such an extent that it can no longer support criticality at commercial power conditions.

**epithermal flux**—Neutron flux which possesses energies greater than thermal energy (0.5 eV) but less than fast energy (1.0 MeV). Sometimes called intermediate flux or energy.

## F

**fission**—The process of splitting a heavy nucleus into two or more nuclei by neutron bombardment. This process is accompanied by the release of large amounts of heat energy, significant amounts of gamma radiation, and one or more neutrons.

**flux**—In general, the intensity of or rate of flow of a fluid, particles or energy across a unit area. With respect to thermal processes, it is the rate of heat transfer across a boundary expressed as BTUs per hour per square foot. With regard to nuclear processes, it is the intensity of radiation in a given area per unit time expressed as the number of particles per second per square centimeter. Typically refers to neutron/cm<sup>2</sup>-second.

**fuel cycle**—The period of time between two successive loadings of new fuel into the reactor.

## G

**gamma energy**—Energy in the form of photons of electromagnetic radiation emitted by nuclei, each such photon being emitted as the result of a quantum transition between two energy levels of the nucleus.

## H

**hot leg**—The reactor coolant exit line from the reactor vessel (where the coolant has picked up its maximum heat) to the steam generator.

**hot shutdown**—A reactor condition in which the reactor is subcritical with the reactor coolant temperature typically between 200°F and 500°F.

**hot standby**—A reactor condition in which the reactor is subcritical with the reactor coolant temperature typically over 500°F and at operating pressure.



## I

**ionization chamber**—A device used for detecting and measuring ionizing radiation. This device provides an electrical current proportional to the incident radiation, which is created by radiation that penetrates the chamber and ionizes the gas therein.

**Inconel**—A specific alloy of mainly nickel and chromium with some iron and manganese that has high strength and good resistance to corrosion.

**isotope**—One of several nuclides having the same number of protons in their nuclei, and hence belonging to the same element, but differing in the number of neutrons and therefore in mass number A, or energy content.

## L

**linear power density**—Expressed in the units of kw/ft; the average linear power density is obtained by dividing the total thermal power by the product of the active core length and the number of fuel rods. The linear power density at a particular location is a function of both core power level and local conditions.

**load follow**—Process of adjusting plant output in response to change in network power demand.

**loss-of-coolant accident (LOCA)**—A postulated design basis accident in which reactor coolant is released from the primary system.

## M

**MWD/MTU**—A unit of measure of fuel burnup in a reactor expressed as megawatt-days of heat output per metric ton of uranium fuel.

**Moderator**—Material in a nuclear reactor to moderate (slow down) neutrons from the high energies at which they are released. Neutrons lose energy by scattering collisions with nuclei of the moderator. A good moderator has high scattering cross section, low capture cross section, and low atomic weight.

**moderator coefficient**—The change in reactor reactivity (per degree of temperature) occurring when the moderator temperature changes. The coefficient is said to be positive when an increase in temperature increases reactivity, negative when an increase in temperature decreases reactivity.

## N

**neutron**—An uncharged particle with a mass nearly equal to the mass of a proton. Neutrons are the particles which sustain a chain reaction in a nuclear reactor.

**neutron flux**—A term used to express the intensity of neutron radiation, expressed as the number of neutrons passing through a unit area in unit time.

**neutrons, delayed**—Neutrons emitted by nuclei in excited states which have been formed in the process of beta decay. (The neutron emission itself is prompt, so that the observed delay is that of the preceding beta emission or emissions.)

**neutrons, fast**—Neutrons of kinetic energy greater than some specified value. This value may vary over a wide range and will be dependent upon the application, such as reactor physics, shielding, or dosimetry.

**noble fission gases**—Gases which result from the fission process and do not combine chemically with other materials. The noble gases are helium, neon, argon, krypton, xenon, and radon.

**nuclide**—Nuclide is a general term that refers to all nuclear species, both stable and unstable, of the elements. Each nuclide is identified by the number of protons and neutrons in it. If it is radioactive, it is called a radionuclide.

## O

**operating base earthquake**—An earthquake specified for the site with half the intensity of the design safe shutdown earthquake. The plant is designed to continue operating through this earthquake.

## P

**power coefficient of reactivity**—The change of reactivity per unit change of reactor thermal power when other variables are constant.

**power defect**—The negative reactivity associated with an increase in reactor core power due to temperature feedback effects from an increase in fuel and moderator temperature.

## R

**rad**—A unit of absorbed radiation. Energy absorption of 0.01 joule per kilogram.

**radioactivity**—Spontaneous nuclear disintegration with emission of particle and/or electromagnetic radiations. The principal types of radioactivity are alpha disintegration, beta decay (negatron emission, positron emission, and electron capture), gamma emission (isometric transition), and neutron emission.

**ramp rate**—A constant rate of change.

**reactivity**—An indication or measure of the departure of reactor conditions from the critical state. Negative values indicate subcriticality, a value of zero indicates criticality and positive values indicate supercriticality. Represented by the symbol  $\rho$ .

**reactor trip**—When control rods are rapidly inserted into the core to quickly take the reactor to a subcritical state.

**REM**—Roentgen equivalent man. The basis for measuring human dosage which takes into account the effect of different types of radiation.

**rod worth**—The reactivity change per unit change in control rod position.

**roentgen**—A radiation exposure measurement. Radiation, that if stopped completely in air, would ionize air to create  $2.58 \times 10^{-4}$  coulomb per kilogram of air.

## S

**shutdown**—The process of making a reactor subcritical or in the state of being in a subcritical condition.

**step change**—An instantaneous change of reactor power from one steady value to another steady value.

**steady state**—A system in which the conditions at each point are not changing.

## T

**T<sub>avg</sub>**—The average temperature in the reactor, halfway between the temperature of the coolant entering and the coolant leaving.

**temperature coefficient of reactivity**—The ratio of the change in reactivity to the change in temperature when the reactivity change is only due to a temperature change.

**tilting factor**—A measure of imbalance in a system that could be balanced. (Examples: steam generator output tilt, reactor coolant differential temperature tilt, and radial and axial flux tilts.)

**transient**—Non-steady condition encountered by a system when going from one state of equilibrium to another.

**turbine trip**—When turbine steam inlet valves are rapidly closed to block steam flow, stopping the turbine.

## U

**unit net efficiency**—Ratio of energy provided by the unit in the form of electricity to that utilized by the unit.

## X

**xenon**—A noble fission gas. One isotope, xenon-135, has a very large absorption cross section, and acts as an important fuel poison in most reactors. It has a half life of 9.2 hours. Most of it is formed by the decay of iodine-135 which is a fission product and has a half life of 6.7 hours.

## Z

**Zircaloy**—An alloy of zirconium with small percentages of tin, iron, chromium and nickel.

**zirconium**—A metallic element, highly resistant to corrosion, used as cladding on nuclear fuel rods.